

SEE MANUFACTURER MINIMUM EXPOSURE DIMENSION TO OBTAIN FM APPROVED QUICK-RESPONSE LISTING.

# SEMI-RECESSED PENDANT QUICK-RESPONSE SPRINKLER(QRS)

Scale: 12" = 1'-0"



DETAIL TITLE: SEMI-RECESSED PENDANT QUICK-RESPONSE SPRINKLER (QRS)

SCALE: 12" = 1'-0"

DATE ISSUED: 03/01/23

CAD DETAIL NO.: SD211313-01

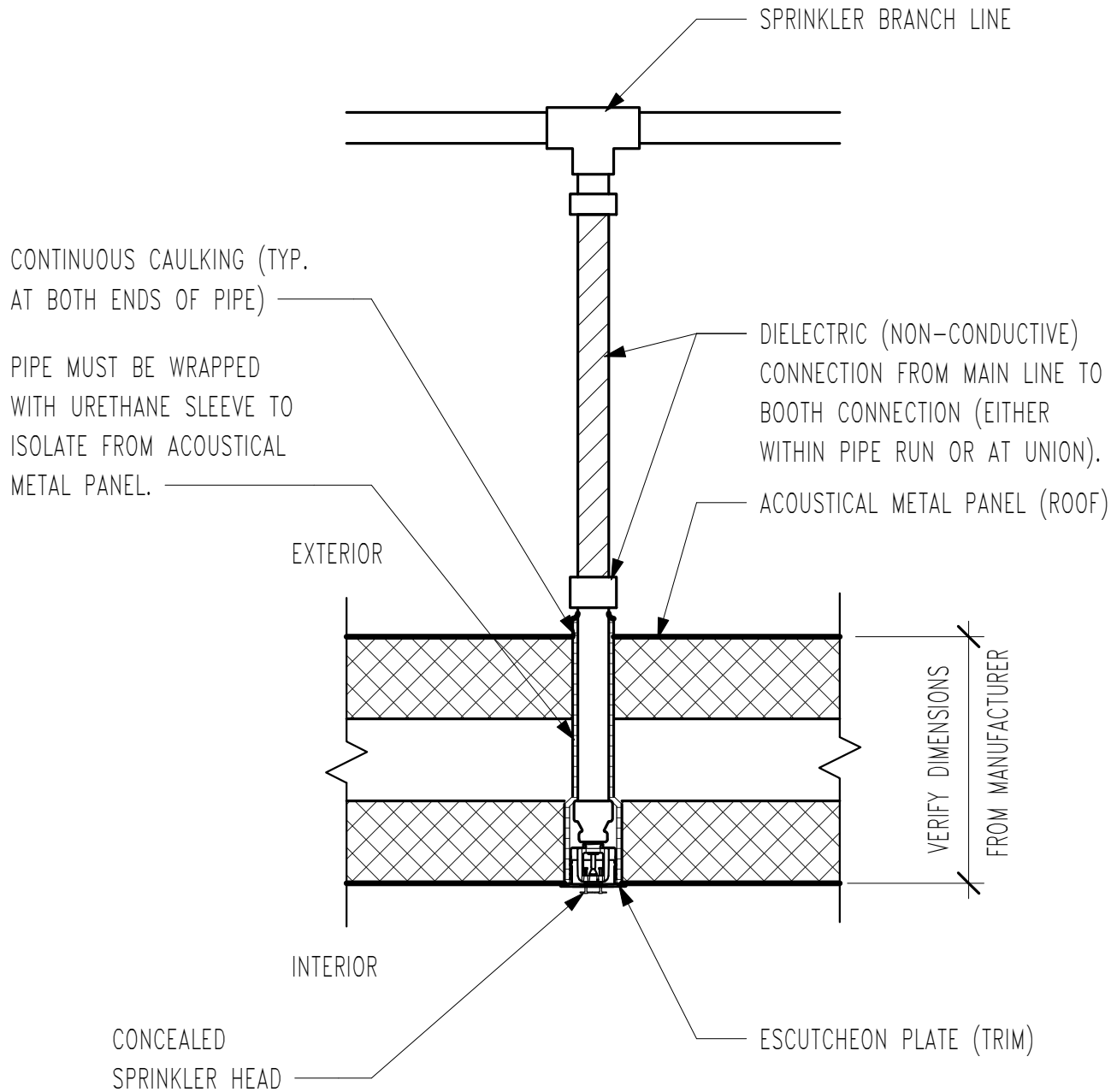

## AUDIOLOGY BOOTH SPRINKLER DETAIL

Scale: N.T.S.

**NOTE:**

CONTACT AUDIOMETRIC BOOTH MANUFACTURER FOR ANY SPECIFIC REQUIREMENT TO MAINTAIN MANUFACTURER ACOUSTICAL WARRANTY.



DETAIL TITLE: AUDIOLOGY BOOTH SPRINKLER DETAIL

SCALE: N.T.S.

DATE ISSUED: 03/01/23

CAD DETAIL NO.: SD211313-02

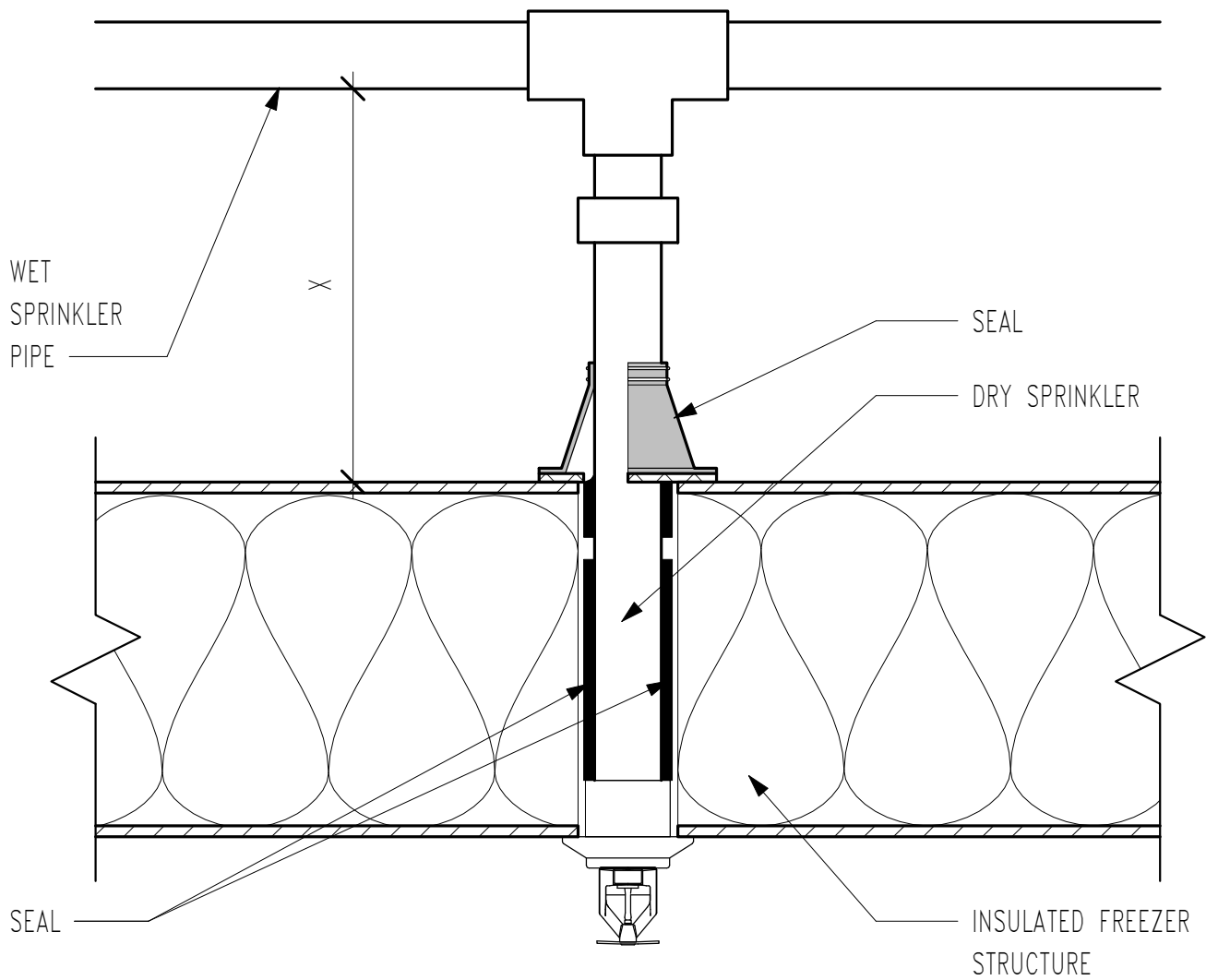

**NOTE:**  
 X = MINIMUM EXPOSED BARREL LENGTH  
 AS SPECIFIED BY SPRINKLER  
 MANUFACTURER & NFPA 13.

# DRY SPRINKLER INSTALLATION

Scale: 3" = 1'-0"



DETAIL TITLE: DRY SPRINKLER INSTALLATION

SCALE: 3" = 1'-0"

DATE ISSUED: 03/01/23

CAD DETAIL NO.: SD211316-01