

NOTES:

1. ALL CONCRETE CURBS AND TRANSITIONS, SHALL HAVE A MINIMUM COMPRESSIVE STRENGTH OF 2,500 PSI.
2. MAXIMUM SPACING ON SCORED JOINTS SHALL BE 15' [4572mm].
3. 1/2" [13mm] THICK EXPANSION JOINTS SHALL BE LOCATED AT TANGENT POINTS IN CURB RETURNS, TRANSITIONS, AND AT A MAXIMUM OF 60' [1828.8cm] INTERVALS. EXPANSION MATERIAL SHALL ALSO BE PLACED BETWEEN CURBS AND ADJACENT STRUCTURES, SIDEWALKS, DRIVEWAYS AND CURB ACCESS RAMPS. THE 1/2" [13mm] JOINT FILLER SHALL EXTEND THE FULL DEPTH OF THE CONCRETE.
4. CONCRETE SHALL BE FINISHED WITH A STEEL TROWEL FOLLOWED BY BRUSHING WITH A FINE BRUSH ALONG THE LENGTH OF THE CURB OR CURB AND GUTTER.
5. SINGLE CURB MAY BE CONSTRUCTED BY THE USE OF FORMS OR MAY BE SLIP FORMED.
6. ALL EXPOSED EDGES AND HAND TOOLED JOINTS SHALL BE FINISHED WITH A TOOL HAVING A 1/4" [6mm] RADIUS UNLESS A LARGER RADIUS IS INDICATED BY THE APPLICABLE STANDARD DETAIL OR PROJECT PLANS.
7. FOR REVEALS OF 6" [152mm] TO LESS THAN 8" [203mm].
8. FOR REVEALS OF 8" [203mm] TO 10" [254mm].

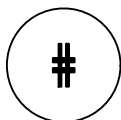
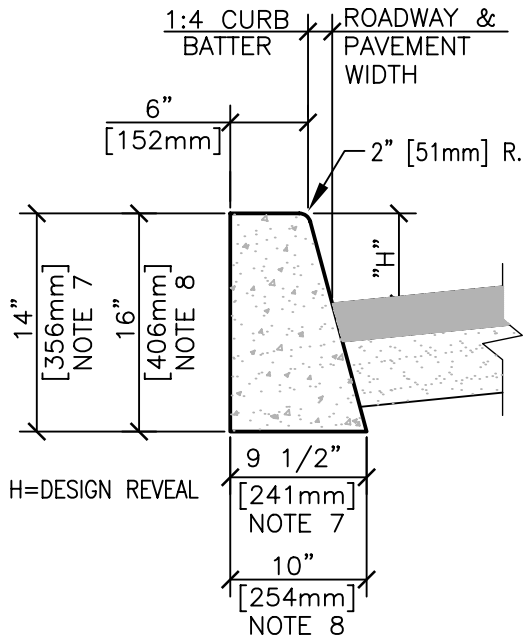

CONCRETE CURB AND TERMINAL SECTION

NTS



Department of
Veterans Affairs

DETAIL TITLE / CONCRETE CURB AND TERMINAL SECTION

SCALE :NONE

DATE ISSUED: DECEMBER 2008

CAD DETAIL NO.: SD320523-17.DWG