

LONGITUDINAL SECTION A

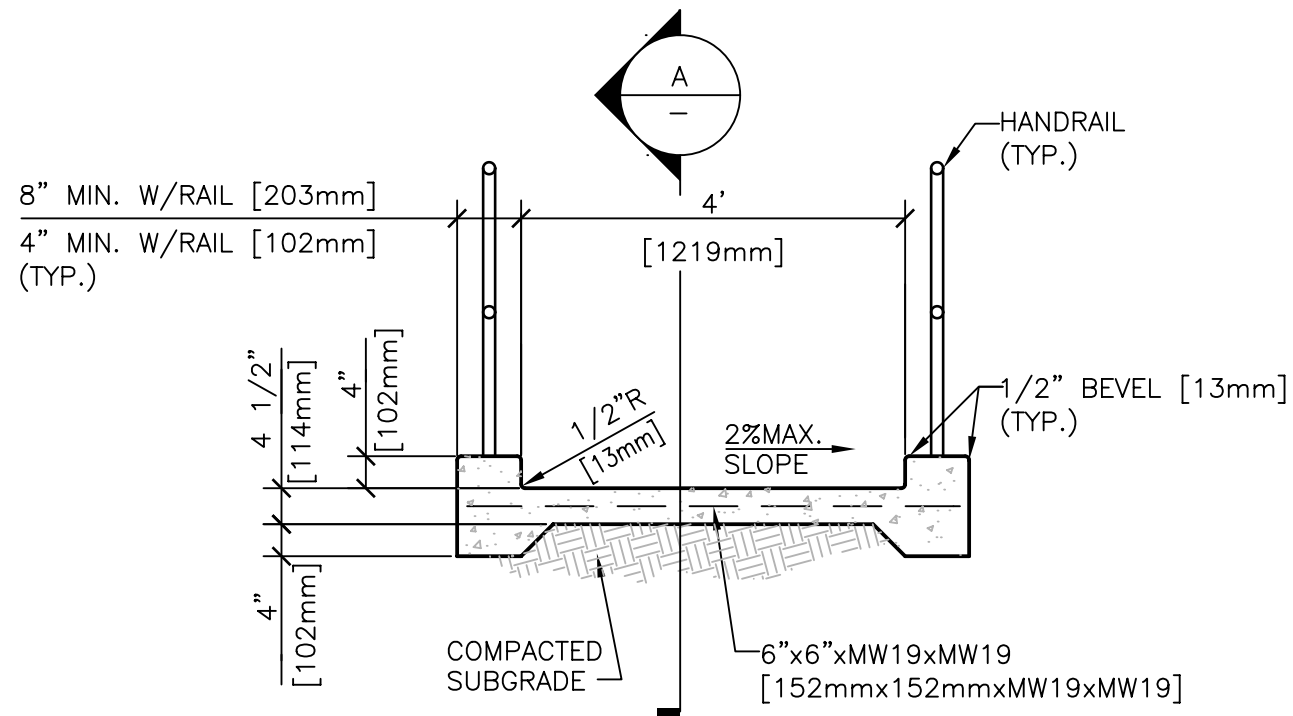

TRAVERSE SECTION B

NOTE:

1. RAMP IS REQUIRED WHERE THE WALK EXCEEDS 3%.
2. IF A RAMP RUN HAS A RISE GREATER THAN 6" [152mm] OR A HORIZONTAL PROJECTION GREATER THAN 72" [1829mm], THEN IT SHALL HAVE HANDRAILS ON BOTH SIDES.
3. MAXIMUM SLOPE OF RAMP SHALL NOT EXCEED 8.33%.
4. SEE ARCHITECTURAL STANDARDS FOR HANDRAIL DETAILS.
5. PROVIDE AN AGGREGATE BASE WHERE SUBSURFACE CONDITIONS WARRANT IT.
6. REFER TO PG-18-13 INDEX.

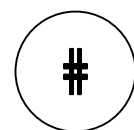

RAMP FOR DISABLED PERSONS

NTS

DETAIL TITLE / RAMP FOR DISABLED PERSONS

SCALE : NONE

DATE ISSUED: DECEMBER 2008

CAD DETAIL NO.: SD320523-01.DWG

Department of
Veterans Affairs

