

0.5 INCH WG [125Pa] TO 2 INCHES WG [500Pa] DUCT RISER SUPPORT

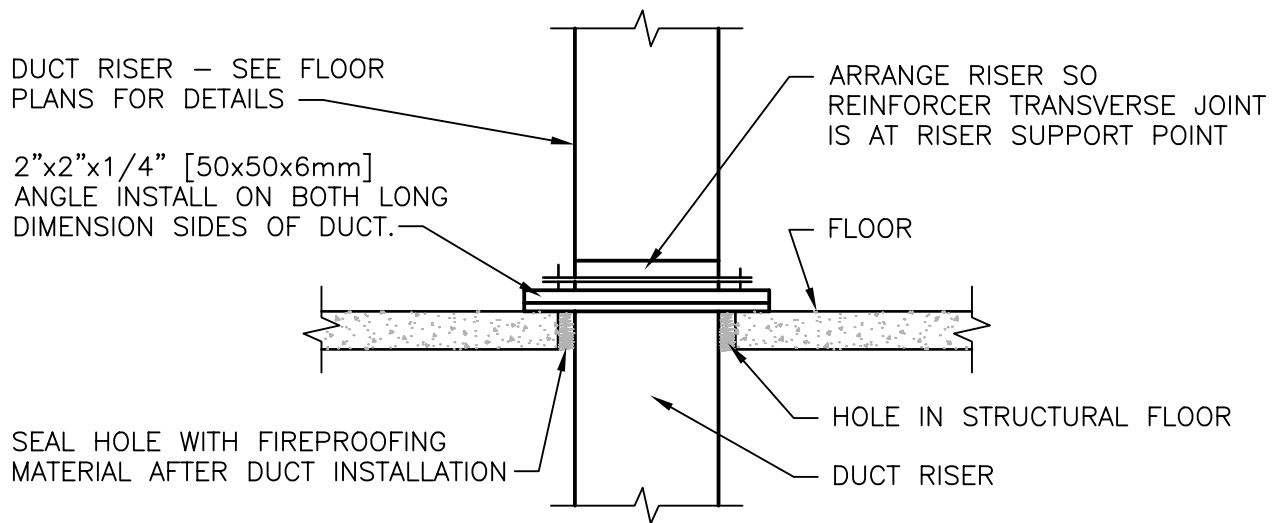

2 INCHES WG [500Pa] TO 4 INCHES WG [1000Pa] DUCT RISER SUPPORT

NOTE:

ALL DUCT WORK RISERS WHICH ARE RUN EXPOSED, SUCH AS THRU ATTIC FLOORS AND FAN ROOM FLOORS SHALL BE PROVIDED WITH A 3" [75mm] HIGH CONCRETE CURB AROUND OPENING FOR DUCT.

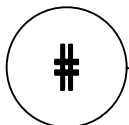

DUCT RISER SUPPORTS

NTS

DESIGNER'S NOTE:

INDICATE ON DRAWING THE DUCT PRESSURE CLASS 2" WG [500Pa] WG, 3" WG [750Pa] OR 4" WG [1000Pa].



Department of
Veterans Affairs

DETAIL TITLE / DUCT RISER SUPPORTS

SCALE :NONE

DATE ISSUED: DECEMBER 2008

CAD DETAIL NO.: SD233100-15.DWG