

PIPE ANCHOR SCHEDULE										
D		P		C		N		S		BOLT PATTERN
mm	in	mm	in	mm	in	mm	in	mm	in	
102	4	16	5/8	19	3/4	102	4	19	3/4	
76	3	13	1/2	13	1/2	102	4	16	5/8	
64	2 1/2	10	3/8	10	3/8	102	4	16	5/8	
51	2	10	3/8	10	3/8	102	4	16	5/8	
38	1 1/2	10	3/8	6	1/4	102	4	13	1/2"	

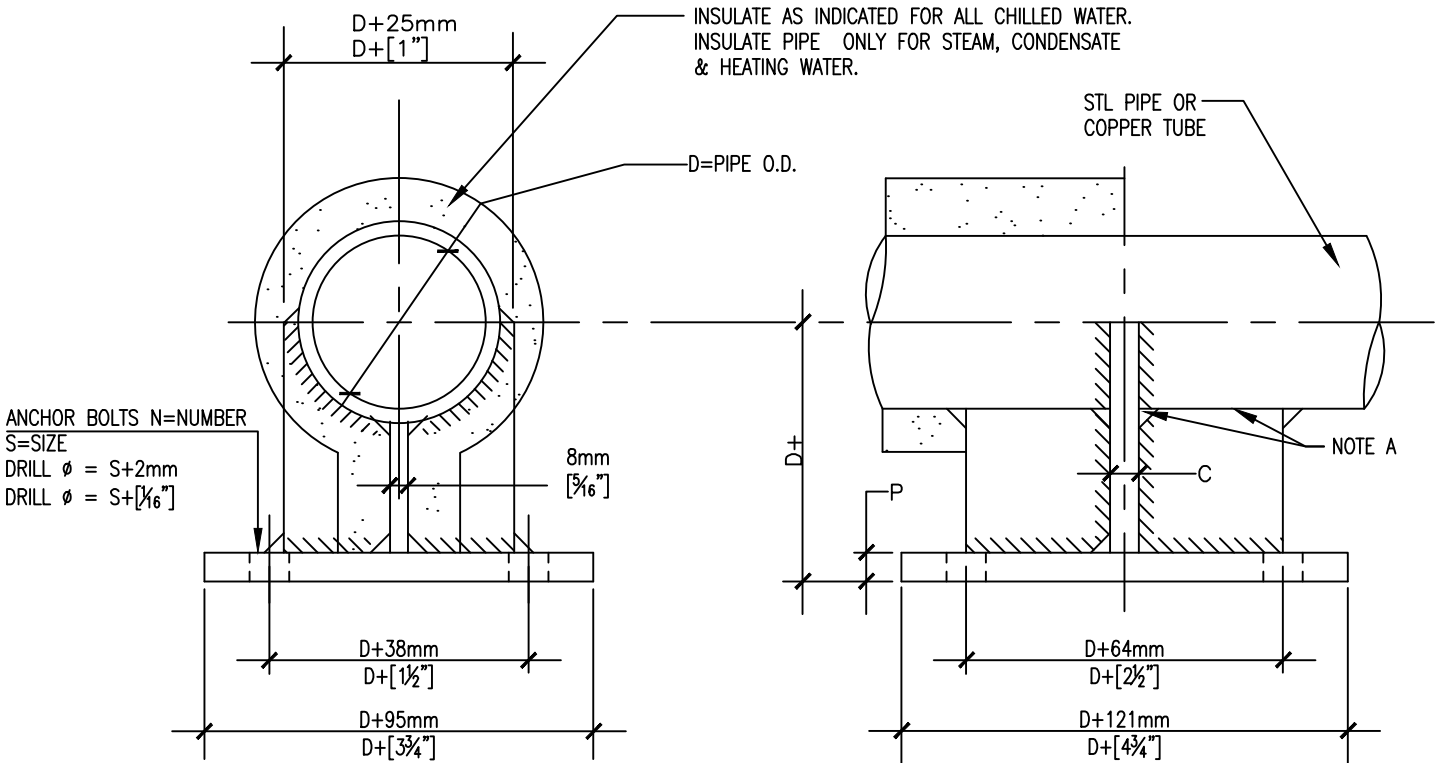

NOTE:  
WHERE USED FOR COPPER TUBE OR PIPE, BRAZE TO FABRICATED STEEL ANCHOR

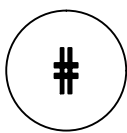

## SMALL PIPE ANCHOR 38-102mm [1 1/2"-4"]

NTS



Department of  
Veterans Affairs

DETAIL TITLE: SMALL PIPE ANCHOR 38-104mm [1-1/2"-4"]

SCALE :NONE

DATE ISSUED: 11/01/2017

CAD DETAIL NO.: SD230511-23.DWG