

NOTE: SHOWING SWING OF DOUBLE EGRESS DOORS.

DOUBLE EGRESS DOOR FRAME

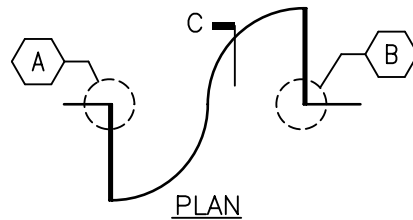

NOTE: SHOWING THE SWING OF DOUBLE EGRESS DOORS.

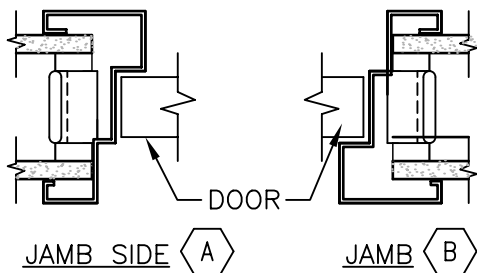

JAMB SIDE A JAMB B

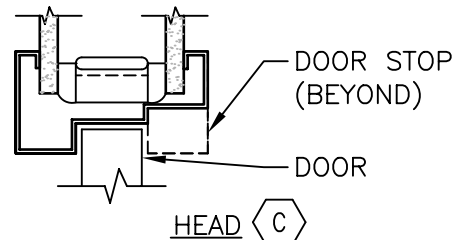

HEAD C

SECTIONS DOUBLE EGRESS DOORS

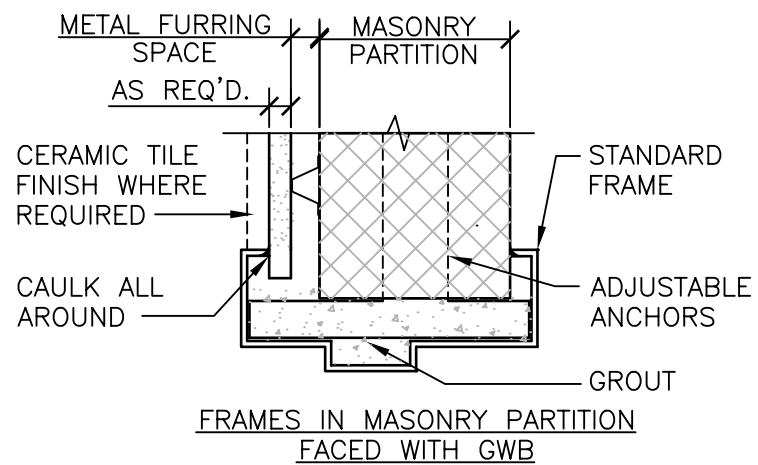

FRAMES IN MASONRY PARTITION FACED WITH GWB

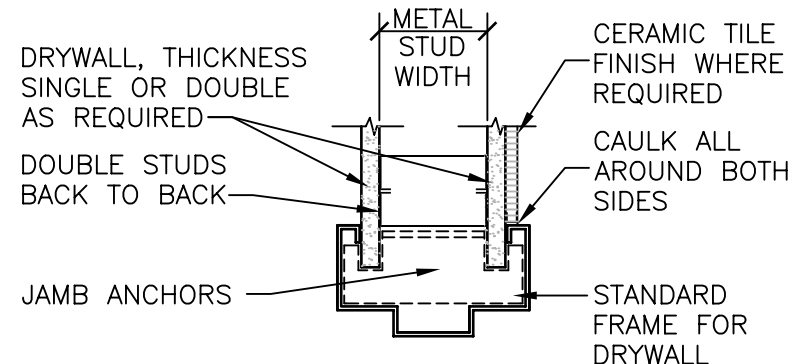

FRAMES IN METAL STUD PARTITIONS

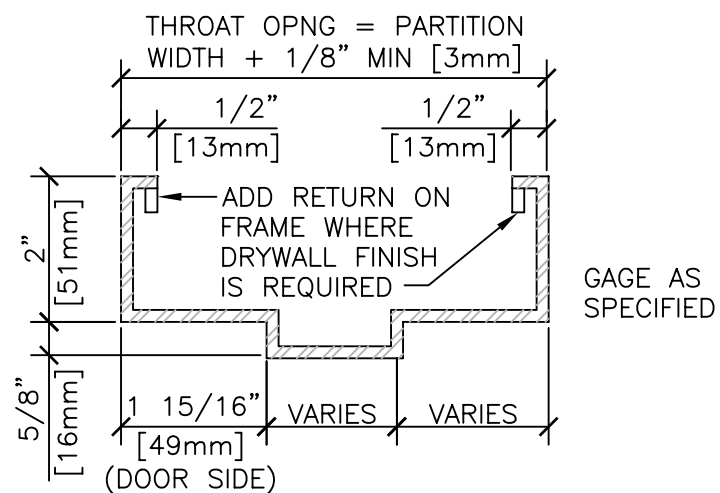

STANDARD DOOR FRAME

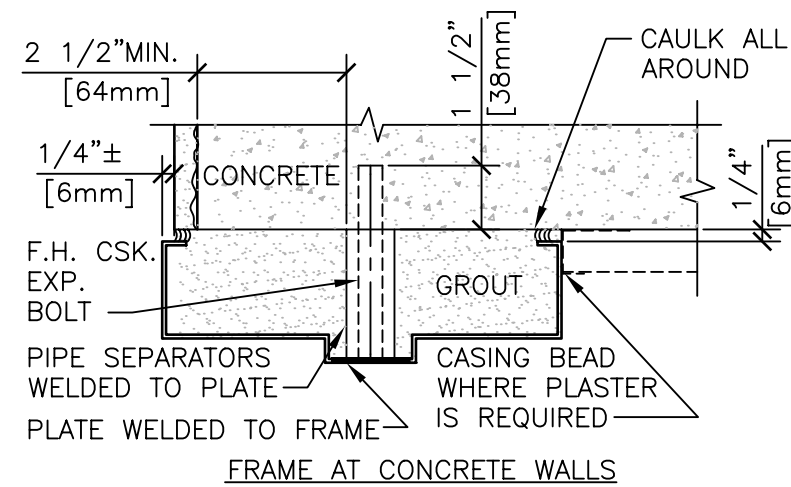

FRAME AT CONCRETE WALLS

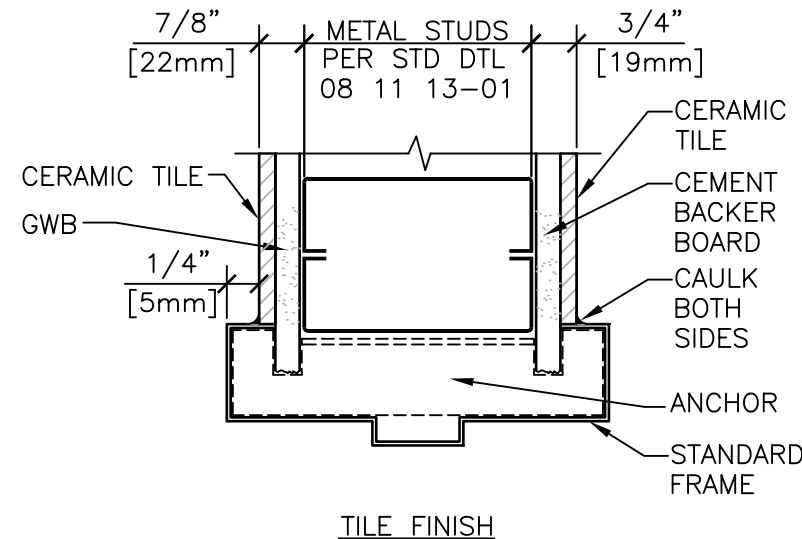

TILE FINISH

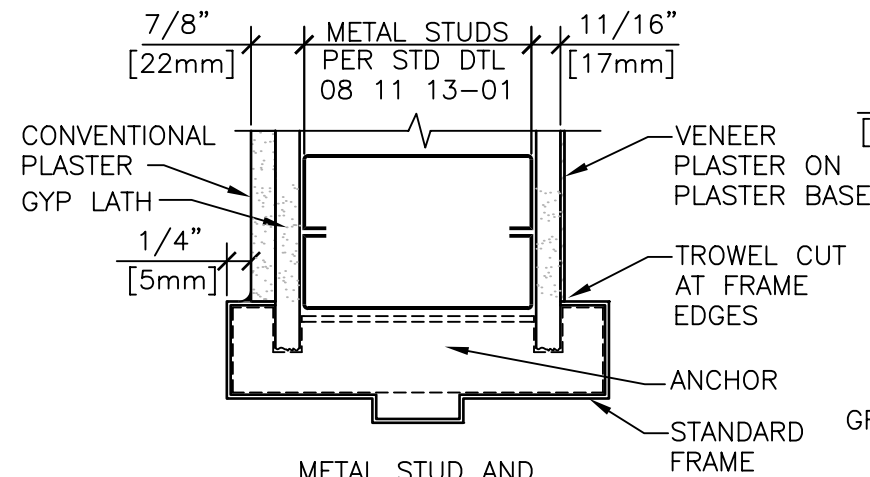

FRAMES WITH METAL STUD AND PLASTER PARTITIONS

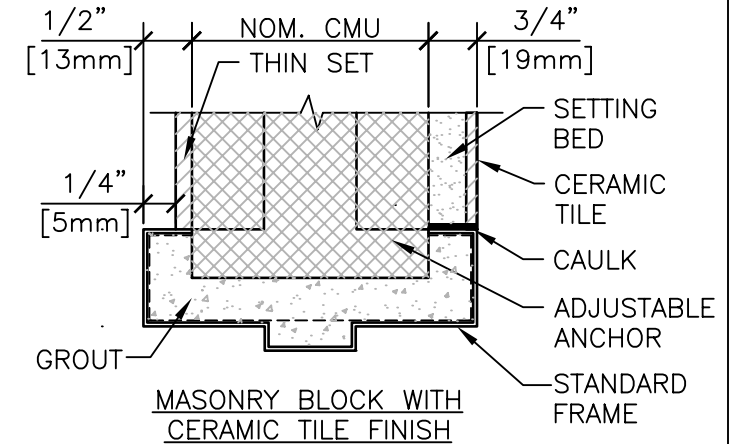

MASONRY BLOCK WITH CERAMIC TILE FINISH

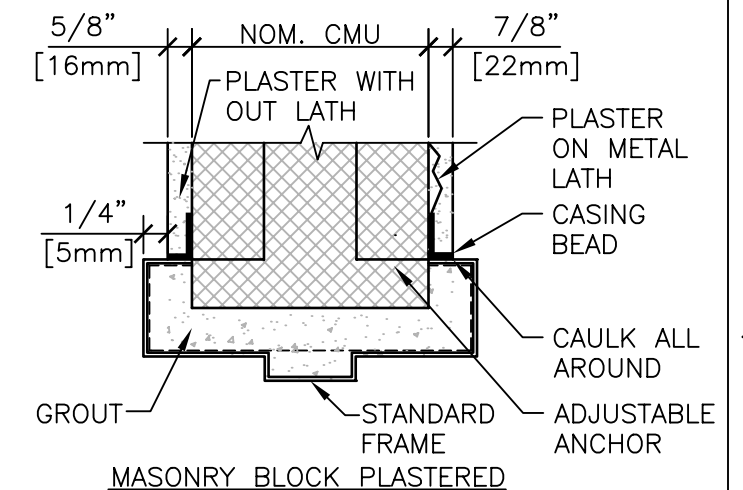

MASONRY BLOCK PLASTERED

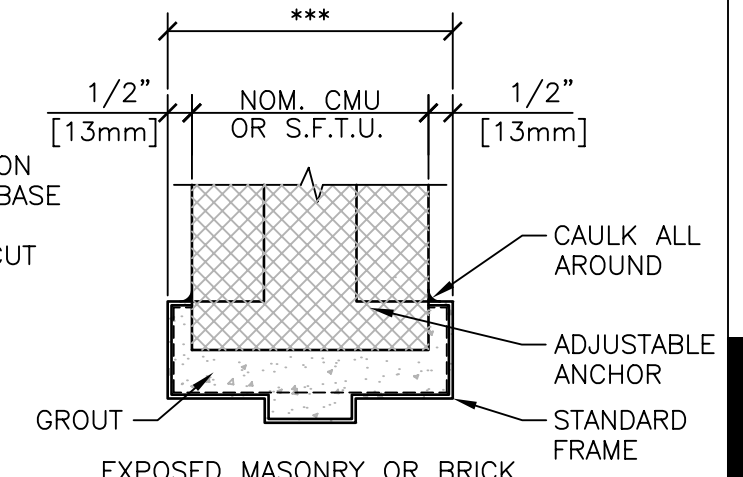

FRAMES IN MASONRY PARTITION

*** FRAME WIDTH FOR NOMINAL MASONRY
 4 3/4" w/ 4" CMU [100 / 100 mm]
 6 3/4" w/ 6" CMU [160 / 150 mm]
 8 3/4" w/ 8" CMU [210 / 200 mm]

INTERIOR DOOR FRAMES

NTS