

VA



U.S. Department
of Veterans Affairs
Office of Construction &
Facilities Management



Telecommunications and Special Telecommunications Systems Design Manual

February 2016

This page intentionally left blank.

Department of Veterans Affairs

Office of Construction & Facilities Management
Facilities Standards Service (003C2B)
425 I Street NW
Washington, DC 20001

- (1)** Photos appearing on the cover of this document are copied from the personal collection of Mr. Forrest Frakes, VACO, Spectrum Management and COMSEC Service Special Communications Team. Mr. Frakes grants permission for their use under the following conditions:
 - (a)** High Frequency (HF) Radio System Equipment Stack with Ancillary Equipment made during a Middle East Asia Site Visit, use only for this manual,
 - (b)** Antenna Farm Lead End Feed Feed-Throughs, Coax Cables, Antenna Mounts and Lightning Protection Grounding System Connections outside the VAMC's Antenna Head End Equipment Room made during the Official VA Two Way Radio Replacement Project, VAMC Syracuse, New York, it may be used in any Official CFM Document,
 - (c)** Inside VAMC Antenna Headend Equipment Room, Very High Frequency (VHF) Radio Equipment Racks with Ancillary Radio Equipment installed as a part of the VA Project and Location in Item (2) (b), it may be used in any Official CFM Document.
- (2)** Photos bottom row – left to right, as you look at the cover:
 - (a)** High Frequency (HF) Radio System Equipment Stack with Ancillary Equipment made during a Middle East Asia Site Visit, use only for this manual,
 - (b)** Antenna Farm Lead End Feed Feed-Throughs, Coax Cables, Antenna Mounts and Lightning Protection Grounding System Connections outside the VAMC's Antenna Head End Equipment Room made during the Official VA Two Way Radio Replacement Project, VAMC Syracuse, New York, it may be used in any Official CFM Document,
 - (c)** Inside VAMC Antenna Headend Equipment Room, Very High Frequency (VHF) Radio Equipment Racks with Ancillary Radio Equipment installed as a part of the VA Project and Location in Item (2) (b), it may be used in any Official CFM Document.
- (3)** Photos top row – left to right, as you look at the cover:
 - (a)** VAMC Rooftop Television Receive Only (TVRO) Satellite Antenna for Education and Medical Media Production Services installed during a separate Official VA Project at the Location in Item (2) (b), it may be used in any Official CFM Document.
 - (b)** Inside of the VAMC Antenna Head End Equipment Room showing VHF Radio and Ancillary secondary equipment installation, at the VA Project and Location in Item (2) (b), it may be used in any Official CFM Document.
 - (c)** Commercial Self Supporting Microwave (M/W) Antenna Tower with Antennas installed located on a mountain top during a South American Site Visit, use only for this manual, and
 - (d)** VAMC Rooftop VHF Antenna Farm, Antenna Mounts, Coaxial Cables installed as a part of the VA Project and Location in Item (2) (b), it may be used in any Official CFM Document.

This page intentionally left blank.

Acknowledgments

Many professionals have generously contributed their expertise to guide the development of this first edition of the VA Telecommunications and Special Systems Telecommunications Design Manual. Chief among them are:

Office of Information & Technology (O5)

Forrest F. Frakes, CET, PC	Senior Telecommunications Specialist, VA OI&T
Keith Van Bakel, ATS	Telecommunication Specialist, VA OI&T
Matthew Hammaker	Voice Engineering Project Manager, VA OI&T

Office of Construction & Facilities Management (OOCFM)

Noella Bond, CO	Contracting Officer, VA CFM
Lam Vu, PE	Contracting Officer's Representative, VA CFM
Zoltan Nagy, RA	Principal Healthcare Architect, VA CFM

Private Sector

This document was created by CannonDesign, under contract to the Department of Veterans Affairs, Facilities Standards Service, Washington, DC, 20001. The following subject matter experts contributed to this manual:

Peter McClive, PE	Senior Vice President, Electrical Engineering
F. Patrick Mahoney, RCDD, CDT	Senior Associate, Technology Services Group
Pete Northern, CDT	Senior Associate, Specifications / 508 Compliance

Technical Content Management

Technical content is supervised and managed by VA Special Communications Subject Matter Experts. Please direct all communications to VA's Special Communications Subject Matter Experts, Spectrum Management and Communications Security (COMSEC) Service (SMCS), at the contact information provided in [Paragraph 1.3](#).

This page intentionally left blank.

TABLE OF CONTENTS

TABLE OF CONTENTS

CHAPTER 1:	1-1
1.0 GENERAL REQUIREMENTS	1-3
1.1 PURPOSE	1-3
1.2 RESPONSIBILITY	1-4
1.3 AUTHORITY HAVING JURISDICTION	1-4
1.4 ABBREVIATIONS AND ACRONYMS	1-5
1.5 COORDINATION	1-6
1.5.1 SERVICE PROVIDER COORDINATION	1-6
1.5.2 PRE-DESIGN SITE SURVEY	1-7
1.6 VA DESIGN CRITERIA	1-7
1.6.1 MASTER SPECIFICATIONS (PG-18-1)	1-7
1.6.2 DEFINING SPECIFIC INSTALLATION METHODS TO BE USED.DESIGN AND CONSTRUCTION PROCEDURES (PG-18-3)	1-8
1.6.3 INCLUDING MISCELLANEOUS DESIGN DETAILS.NATIONAL CAD STANDARD, VHA APPLICATION GUIDE & STANDARD DETAILS (PG-18-4)	1-8
1.6.4 EQUIPMENT REFERENCE MANUAL (PG-18-5)	1-8
1.6.5 DESIGN MANUALS (PG-18-10)	1-8
1.6.6 VA DIRECTIVE 0730 – VA SECURITY AND LAW ENFORCEMENT HANDBOOK	1-10
1.6.7 DESIGN GUIDES (PG-18-12)	1-10
1.6.8 ARCHITECT/ENGINEER REVIEW CHECKLIST	1-11
1.6.9 COST ESTIMATING MANUAL	1-12
1.6.10 SUSTAINABLE DESIGN AND ENERGY REDUCTION MANUAL	1-12
1.6.11 SEISMIC DESIGN REQUIREMENTS (H-18-8)	1-13
1.6.12 VA HOSPITAL BUILDING SYSTEM (VAHBS)	1-13
1.6.13 COMPUTER AIDED FACILITIES MANAGEMENT REQUIREMENTS (CAFM)	1-13
1.6.14 VETERANS BENEFITS ADMINISTRATION; VBA INFORMATION SECURITY PROGRAM, VBA IRM DIRECTIVE NO. 5.00.01	1-13
1.7 OTHER DESIGN CRITERIA	1-14
1.7.1 ENERGY CONSERVATION	1-14
1.7.2 DOE INTERIM FINAL RULE	1-14
1.7.3 ADDITIONAL MEASURES (MOU)	1-14
1.8 APPLICABLE CODES AND STANDARDS	1-15
1.8.1 GENERAL	1-15
1.8.2 INDUSTRY STANDARDS:	1-18
1.8.3 LOCAL CODES AND CONDITIONS	1-21
1.9 DESIGN REQUIREMENTS	1-21
1.9.1 CRITERIA UNIQUE TO VA	1-22
1.10 CALCULATIONS	1-24
1.10.1 GENERAL	1-24
1.10.2 LOAD CALCULATIONS	1-25
1.10.3 SEISMIC BRACING	1-25
1.11 TRANSPORT SYSTEMS	1-25

TABLE OF CONTENTS

1.12	RENOVATION TO EXISTING SITES AND BUILDINGS	1-25
1.12.1	DRAWINGS	1-25
1.12.2	MODIFICATION VERSUS REPLACEMENT.....	1-26
1.12.3	AGE AND PHYSICAL CONDITION.....	1-26
1.12.4	PARTS AVAILABILITY.....	1-26
1.12.5	CONDUIT AND BOXES	1-26
1.12.6	CONDUCTORS	1-27
1.12.7	WORK AREA OUTLETS.....	1-27
1.12.8	PATCHPANELS AND PUNCHDOWN BLOCKS.....	1-27
1.12.9	GOVERNMENT RETAINED EQUIPMENT (AKA GFE)	1-27
1.12.10	CONTINUITY OF SERVICE.....	1-27
1.12.11	COMPATIBILITY.....	1-27
CHAPTER 2:		2-1
2.0	RACEWAYS, PATHWAYS, WIREAYS, CABLE TRAYS, CABLE DUCTS, CONDUITS, BOXES AND EQUIPMENT	2-0
2.1	CABLE PATHWAYS.....	2-0
2.1.1	CONDUITS AND BOXES	2-0
2.2	HORIZONTAL CONDUITS.....	2-3
2.2.1	PARTITIONED CABLE TRAYS AND OPEN WIREWAYS	2-4
2.2.2	TELECOMMUNICATIONS CABLE DUCTS UNDER CELLULAR FLOORS... ..	2-4
2.3	VERTICAL RISERS	2-5
2.3.1	TELECOMMUNICATIONS OUTLETS (TCO)	2-5
2.4	DRAWINGS	2-6
2.5	CONCEALED AND EXPOSED CONDUITS.....	2-6
2.6	UNDERGROUND DUCTS AND CONDUITS	2-6
2.7	INDOOR CONDUITS AND PATHWAYS	2-7
2.8	SPARE CONDUITS.....	2-8
2.9	STAIRWELLS	2-8
2.10	UNDERFLOOR DUCT SYSTEMS	2-8
2.11	ROOMS REQUIRING UNIQUE CONDUIT ATTENTION	2-8
2.11.1	RADIOLOGY ROOMS	2-8
2.11.2	TELEPHONE EQUIPMENT ROOM (TER) AND TELEPHONE OPERATOR'S ROOM (IF REQUIRED) (CONTACT OI&T'S TVE [RE PARAGRAPH 1.3] FOR SPECIFIC TECHNICAL ASSISTANCE IN THESE VOICE/PBX ENVIRONMENTS)	2-9
2.12	POKE-THRU, TELE-POWER POLE.....	2-10
2.13	ETHYLENE OXIDE STERILIZATION AREA.....	2-10
2.14	RATED CONSTRUCTION	2-10
CHAPTER 3:		3-1
3.0	WORK AREA OUTLET AND HORIZONTAL CABLING REQUIREMENTS .	3-0
3.1	GENERAL	3-0
3.2	TIP HORIZONTAL MEDIA SELECTION	3-1
3.2.1	BALANCED TWISTED PAIR CABLING	3-1
3.2.2	WIRELESS AND FREQUENCY COORDINATION	3-2
3.3	DISCRETE ANTENNA SYSTEMS.....	3-3
3.3.1	DISTRIBUTED (IN HOUSE) ANTENNA SYSTEM (DAS)	3-3

TABLE OF CONTENTS

3.3.2	WIRELESS MEDICAL TELEMETRY SYSTEM, (WMTS)	3-4
3.3.3	INTRA-BUILDING WIRELESS SYSTEM, WIRELESS LOCAL AREA NETWORK (WLAN)	3-4
3.3.4	FCC & OSHA SAFETY OF LIFE COMPLIANCE AND RESTRICTIONS OF USE.....	3-7
3.4	CABLE LENGTH.....	3-8
3.4.1	BALANCED TWISTED PAIR CABLE LENGTH	3-8
3.4.2	OPTICAL FIBER CABLE	3-9
3.4.3	COAXIAL CABLE.....	3-10
3.5	SPECIFIC APPLICATIONS	3-10
3.5.1	SURGERY ROOMS.....	3-10
3.5.2	EXTERIOR OUTLETS.....	3-10
3.5.3	OFFICES AND ADMINISTRATIVE AREAS.....	3-11
3.5.4	LABORATORIES AND RESEARCH FACILITIES	3-11
3.5.5	MENTAL HEALTH (PSYCHIATRIC) PATIENT ROOMS	3-11
3.6	VIDEO SURVEILLANCE.....	3-11
3.6.1	TELECOMMUNICATIONS ENCLOSURES.....	3-11
3.6.2	DIRECT ATTACH MODIFIED PERMANENT LINKS	3-11
3.6.3	SURGE PROTECTION	3-12
3.7	TELECOMMUNICATIONS ROOMS.....	3-12
3.8	ADAAD REQUIRMENTS (2010 AMERICANS WITH DISABILITIES ACT STANDARDS FOR ACCESSIBLE DESIGN) CHECK TABLE OF CONTENTS NUMBERING AND LINK	3-12
3.8.1	ADAAD PROVIDES THE FOLLOWING INSTALLATION HEIGHT REQUIREMENTS: OPERABLE PARTS SHALL BE PLACED WITHIN ONE OR MORE OF THE REACH RANGES BELOW.	3-12
3.8.2	POOL AREAS.....	3-15
3.8.3	PUBLIC TELEPHONES.....	3-15
3.9	BUILDING AUTOMATION SYSTEMS	3-16
	CHAPTER 4:	4-1
4.0	GENERAL	4-1
4.1	INTERIOR CIRCULATING GROUNDING SYSTEM	4-1
4.1.1	INTERNAL TELECOMMUNICATIONS MAIN GROUNDING BUSBAR (TMGB)	4-1
4.1.2	TELECOMMUNICATIONS BONDING BACKBONE	4-2
4.1.3	TELECOMMUNICATIONS GROUND BUSBAR TGB.....	4-2
4.1.4	SUPPLEMENTAL BONDING GRID (SBG (A.K.A. UNDERFLOOR GROUNDING GRIDS))	4-2
4.1.5	BONDING WITHIN RACKS AND CABINETS	4-3
4.2	EXTERNAL COMMUNICATIONS GROUNDING SYSTEM	4-4
4.2.1	GROUNDING	4-4
4.2.2	FACILITY LIGHTNING PROTECTION SYSTEM	4-4
4.2.3	APPROVED BONDING METHODS.....	4-4
4.2.4	EXOTHERMIC WELDING:	4-4
4.2.5	IRREVERSIBLE HIGH COMPRESSION FITTINGS.....	4-4
4.2.6	EXTERNAL COMMUNICATIONS MAIN LIGHTING GROUNDING BUSBAR (CMLGB).....	4-5

TABLE OF CONTENTS

4.2.7	COMMUNICATIONS CLPS COMPONENTS.....	4-5
4.2.8	CORROSION PROTECTION.....	4-6
4.3	ANTENNA FARM COMPONENTS – SHALL BE CONNECTED TO THE EXTERNAL CLPS:.....	4-6
4.3.1	IF A FACILITY EXTERNAL LPGS DOES OR WILL NOT EXIST	4-7
CHAPTER 5:		5-1
5.0	TELECOMMUNICATIONS INFRASTRUCTURE PLANT (TIP).....	5-3
5.1	TIP REQUIREMENTS.....	5-3
5.2	BACKBONE DISTRIBUTION	5-3
5.2.1	GENERAL	5-3
5.2.2	ROUTE DIVERSITY	5-4
5.3	OUTSIDE PLANT CABLING.....	5-4
5.3.1	BACKBONE TOPOLOGIES	5-4
5.3.2	CABLING TYPES	5-5
5.4	OPTICAL FIBER CONSIDERATIONS.....	5-6
5.4.1	CENTRALIZED OPTICAL FIBER CABLING OR PASSIVE OPTICAL NETWORK (PON)	5-6
5.4.2	BLOWN FIBER-OPTICS (ALTERNATE FIBER OPTIC CABLE INSTALLATION METHOD).....	5-7
5.5	CROSS-CONNECTION SYSTEM (CCS) CONNECTING HARDWARE	5-8
5.5.1	INSULATION DISPLACEMENT BLOCKS	5-8
5.5.2	PATCH PANELS	5-9
5.6	LOADS FED FROM UNINTERRUPTIBLE POWER SUPPLY (UPS).....	5-9
5.7	TELECOMMUNICATIONS ROOMS.....	5-9
5.7.1	GENERAL	5-9
5.7.2	SPACE FOR FUTURE EQUIPMENT	5-10
CHAPTER 6:		6-1
6.0	GENERAL	6-3
6.0.1	SERVICE PROVIDERS.....	6-3
6.1	ENTRANCES	6-3
6.1.1	DEMARC ROOM	6-3
6.1.2	ANTENNA EQUIPMENT	6-4
6.1.3	FACILITY BUILDING ENTRANCES	6-5
6.1.4	BONDING TO GROUND.....	6-6
CHAPTER 7:		7-1
7.0	GENERAL	7-3
7.1	SPECIAL COMMUNICATION SYSTEMS.....	7-3
7.2	SPECIAL COMMUNICATION SYSTEMS IDENTIFICATION.....	7-3
7.2.1	GENERAL	7-3
7.2.2	COMMUNICATIONS INFRASTRUCTURE SYSTEMS	7-3
7.2.3	TELECOMMUNICATIONS INFRASTRUCTURE PLANT (TIP).....	7-3
7.2.4	COMMUNICATIONS CIRCULATING GROUNDING SYSTEM (CCGS) – (REFER TO PG-18-10, EDM & OI&T DESIGN GUIDE, TELECOMMUNICATIONS GROUNDING BUSS (TGB)	7-5
7.2.5	COMMUNICATIONS LIGHTNING PROTECTION GROUNDING SYSTEM (LPGS).....	7-5

TABLE OF CONTENTS

7.2.6	LIFE SAFETY SYSTEMS (SOMETIMES CLASSIFIED AS “CRITICAL SERVICE”)	7-9
7.2.7	EMERGENCY SYSTEMS	7-11
7.2.8	PATIENT, STAFF AND PUBLIC SAFETY SYSTEMS	7-19
7.2.9	OTHER SPECIAL COMMUNICATIONS SYSTEMS	7-22
7.2.10	SPECIAL COMMUNICATIONS “SEPARATED” SYSTEMS	7-26
7.2.11	OI&T SYSTEMS REQUIRING AHJ SMCS 005OP2H3 CO-ORDINATION ..	7-35
7.2.12	SPECIAL MEDICAL COMMUNICATIONS SYSTEMS (SMCS)	7-37
	CHAPTER 8:	8-2
8.0	GENERAL	8-5
8.1	ROOM TYPES AND DEFINITIONS	8-5
8.1.1	GENERAL	8-5
8.1.2	ANTENNA (RADIO) HEADEND EQUIPMENT ROOM	8-5
8.1.3	DEMARC ROOM	8-5
8.1.4	TELEPHONE OPERATORS ROOM (TOR) (IF USED)	8-6
8.1.5	MAIN COMPUTER ROOM (MCR)	8-7
8.1.6	TELECOMMUNICATIONS ROOM (TR)	8-7
8.1.7	POLICE, ENGINEERING, AND EMERGENCY MANAGEMENT CONTROL ROOMS, AND OTHER DESIGNATED ROOMS	8-8
8.2	ELECTRICAL REQUIREMENTS	8-8
8.2.1	GENERAL	8-8
8.2.2	POWER	8-8
8.2.3	LIGHTING	8-9
8.2.4	SECURITY	8-9
8.2.5	CABLE AND WIRE PATHWAYS	8-10
8.3	ANTENNA HEADEND EQUIPMENT ROOM	8-10
8.3.1	GENERAL	8-10
8.3.2	LOCATION	8-10
8.3.3	CONFIGURATION	8-10
8.3.4	FIRE PROTECTION	8-11
8.3.5	GROUNDING	8-11
8.3.6	POWER	8-12
8.3.7	LIGHTING	8-12
8.3.8	SECURITY	8-12
8.3.9	WIRE MANAGEMENT	8-13
8.4	DEMARC ROOM	8-13
8.4.1	LOCATION	8-13
8.5	MAIN COMPUTER ROOM (MCR)	8-14
8.5.1	GENERAL	8-14
8.5.2	LOCATION	8-14
8.5.3	ELECTRICAL REQUIREMENTS	8-14
8.5.4	LIGHTNING	8-15
8.5.5	GROUNDING	8-15
8.5.6	SECURITY	8-15
8.5.7	CABLE MANAGEMENT	8-16
8.5.8	GROUNDING	8-16
8.5.9	ALTERNANTE MCR	8-16

TABLE OF CONTENTS

8.6.9	MCR'S OPERATOR'S ROOM (MCOR)	8-16
8.5.10	GROUNDING	8-17
8.5.11	TELEPHONE EQUIPMENT (TER) AND TELEPHONE OPERATORS ROOMS (TOR) - (IF USED).....	8-17
8.6	TELECOMMUNICATIONS ROOM (TR)	8-18
CHAPTER 9:		9-1
9.0	GENERAL	9-1
9.1	PATIENT WALL SYSTEMS.....	9-1
9.1.1	PREFABRICATED BEDSIDE PATIENT UNIT (PBPU)	9-1
9.1.2	SPECIALIZED TECHNICAL ASSISTANCE.....	9-1
9.2	BEHAVIORAL HEALTH (AKA PSYCHIATRIC OR MENTAL HEALTH) AREA.....	9-1
9.2.1	ROOMS	9-1
9.2.2	AREA DOOR CONTROL AND SIGNAL SYSTEM	9-2
9.2.3	SPECIALIZED TECHNICAL ASSISTANCE.....	9-3
9.3	NARCOTICS STORAGE ALERTING AND SIGNAL SYSTEM (NSAS)	9-3
9.3.1	SPECIALIZED TECHNICAL ASSISTANCE.....	9-4
9.4	SPECIALIZED MEDICAL TIME KEEPING DEVICES.....	9-4
9.4.1	MEDICAL ELAPSED TIME INDICATOR (METI)	9-4
9.4.2	MEDICAL SYNCHRONIZED CLOCK SYSTEM (MSCS).....	9-5

CHAPTER 1: TABLE OF CONTENTS

CHAPTER 1: TABLE OF CONTENTS

1.0	GENERAL REQUIREMENTS	1-3
1.1	PURPOSE.....	1-3
1.2	RESPONSIBILITY	1-4
1.3	AUTHORITY HAVING JURISDICTION	1-4
1.4	ABBREVIATIONS AND ACRONYMS	1-5
1.5	COORDINATION	1-6
1.5.1	SERVICE PROVIDER COORDINATION.....	1-6
1.5.2	PRE-DESIGN SITE SURVEY	1-7
1.6	VA DESIGN CRITERIA	1-7
1.6.1	MASTER SPECIFICATIONS (PG-18-1)	1-7
1.6.2	DEFINING SPECIFIC INSTALLATION METHODS TO BE USED.DESIGN AND CONSTRUCTION PROCEDURES (PG-18-3)	1-8
1.6.3	INCLUDING MISCELLANEOUS DESIGN DETAILS.NATIONAL CAD STANDARD, VHA APPLICATION GUIDE & STANDARD DETAILS (PG-18- 4)	1-8
1.6.4	EQUIPMENT REFERENCE MANUAL (PG-18-5).....	1-8
1.6.5	DESIGN MANUALS (PG-18-10)	1-8
1.6.6	VA DIRECTIVE 0730 – VA SECURITY AND LAW ENFORCEMENT HANDBOOK	1-10
1.6.7	DESIGN GUIDES (PG-18-12).....	1-10
1.6.8	ARCHITECT/ENGINEER REVIEW CHECKLIST.....	1-11
1.6.9	COST ESTIMATING MANUAL	1-12
1.6.10	SUSTAINABLE DESIGN AND ENERGY REDUCTION MANUAL.....	1-12
1.6.11	SEISMIC DESIGN REQUIREMENTS (H-18-8)	1-13
1.6.12	VA HOSPITAL BUILDING SYSTEM (VAHBS)	1-13
1.6.13	COMPUTER AIDED FACILITIES MANAGEMENT REQUIREMENTS (CAFM).....	1-13
1.6.14	VETERANS BENEFITS ADMINISTRATION; VBA INFORMATION SECURITY PROGRAM, VBA IRM DIRECTIVE NO. 5.00.01.....	1-13
1.7	OTHER DESIGN CRITERIA	1-14
1.7.1	ENERGY CONSERVATION	1-14
1.7.2	DOE INTERIM FINAL RULE	1-14
1.7.3	ADDITIONAL MEASURES (MOU)	1-14
1.8	APPLICABLE CODES AND STANDARDS.....	1-15
1.8.1	GENERAL	1-15
1.8.2	INDUSTRY STANDARDS:	1-18
1.8.3	LOCAL CODES AND CONDITIONS	1-21
1.9	DESIGN REQUIREMENTS.....	1-21
1.9.1	CRITERIA UNIQUE TO VA	1-22
1.10	CALCULATIONS	1-24
1.10.1	GENERAL	1-24

CHAPTER 1: TABLE OF CONTENTS

1.10.2	LOAD CALCULATIONS	1-25
1.10.3	SEISMIC BRACING.....	1-25
1.11	TRANSPORT SYSTEMS	1-25
1.12	RENOVATION TO EXISTING SITES AND BUILDINGS	1-25
1.12.1	DRAWINGS	1-25
1.12.2	MODIFICATION VERSUS REPLACEMENT.....	1-26
1.12.3	AGE AND PHYSICAL CONDITION.....	1-26
1.12.4	PARTS AVAILABILITY.....	1-26
1.12.5	CONDUIT AND BOXES	1-26
1.12.6	CONDUCTORS	1-27
1.12.7	WORK AREA OUTLETS.....	1-27
1.12.8	PATCHPANELS AND PUNCHDOWN BLOCKS.....	1-27
1.12.9	GOVERNMENT RETAINED EQUIPMENT (AKA GFE)	1-27
1.12.10	CONTINUITY OF SERVICE.....	1-27
1.12.11	COMPATIBILITY.....	1-27

CHAPTER 1: GENERAL REQUIREMENTS

1.0 GENERAL REQUIREMENTS

1.1 PURPOSE

- (a) This manual, when used in conjunction with CFM's Electrical Design Manual (EDM), Physical Security Design Manual (PSDM) and Office of Information and Technology Design Guide (OI&T-DG), forms VA's minimum requirements to provide telecommunications engineers and designers (hereafter referred as design professionals) essential information needed for the planning and design of OI&T, Facilities Management Service (FMS) and Emergency Management and Resilience (OSP) Special Telecommunications Systems (hereinafter referred to as low voltage communications or systems) vital for OSP, FMS and OI&T physical locations and interfaces **in all** Department of Veterans Affairs (VA) Facility Projects.
- (b) Special systems are identified as those communications systems that are not "voice" (formerly telephone Private Branch Exchange (PBX) managed), data (including Voice over Internet protocol (VoIP)), Local Area Network (LAN), Wide Area Network (WAN), fire alarm or related functions. Provide systems described in this manual as determined and approved by project requirements.
- (c) Not all systems may be required, and not all required systems may be included in this manual. A list of typical OSP and FMS Special Communications Systems, Performance Ratings and Technical Information is provided in **Chapter 7**; OI&T locations in Chapter 8 and Project Contact Information in **Paragraph 1.3**.
- (d) Systems designed with this manual and referenced documents, must meet their primary objective of providing safe, reliable, and fully functioning (aka "turnkey") installation as described by the system's approved Office of Construction & Facilities Management (CFM) Master and certain AHJ, VACO's Spectrum Management and COMSEC Service (SMCS), and other project approved OI&T supplemental technical specifications.
- (e) Telecommunication and Special Telecommunication Systems are dependent on electrical power for their operation and function. Therefore, electrical power design shall be part of a complete design effort which will render the installed systems operational and functional. Electrical power design must be performed by licensed electrical engineers in accordance with all applicable codes and VA's EDM. Electrical power design shall be shown on electrical drawings.

CHAPTER 1: GENERAL REQUIREMENTS

- (f) In order to provide the latitude needed for new technologies and concepts, technical deviations from stipulations of this manual, may be made only when approved by VA's AHJ for Special Low Voltage Communications, Communications Security (COMSEC) and Radio Frequency (RF) Management and OI&T's Telephone Voice Engineering (TVE) for voice / telephone functions.
- Deviations are not permitted from requirements included in public laws, federal regulations, executive orders, and applicable codes.
 - Moreover, deviations shall result in a safe, reliable and fully functional system.

1.2 RESPONSIBILITY

- (a) All necessary professional services to perform planning and design of the systems for the project shall be provided by the design professional. The design professional is responsible for providing the professional design in accordance with the contract, good engineering practices, Government Codes, Standards and Executive Orders, VA standards, VA project-specific requirements, National and Local Codes and applicable Industry Standards, ***whichever is the more stringent.***
- (b) The term "provide", where used herein, shall mean the same as:
- Surveyed, developed, designed, engineered and documented by the design professional, and
 - Furnished, installed, and tested
- (c) The Telecommunications Infrastructure Plant (TIP) must be designed and installed in accordance with CFM's Master Construction Specifications (PG-18-1) <http://www.cfm.va.gov> including the following that must be the catalyst for all telecommunications TIP systems.
- Please see Paragraph 7.2.3 THIS for these specific documents.
 - Telecommunications Industry Association (TIA) Standards provided herein. (TIA specifications can be purchased at <http://www.tiaonline.org/standards/>)
- (d) Telecommunications design must be performed and stamped by a BICSI® Registered Communications Distribution Designer (RCDD®) for all projects.

1.3 AUTHORITY HAVING JURISDICTION

- (a) Unless otherwise directed by VA, the Authority Having Jurisdiction (AHJ) for Special Low Voltage OSP and FMS Telecommunications Systems, COMSEC and VA's RF Frequency Management is:

CHAPTER 1: GENERAL REQUIREMENTS

- VACO's Spectrum Management and COMSEC Service's Special Communications Team, (SMCS – OSP 007):

Department of Veterans Affairs
810 Vermont Avenue, NW, Room B47
Washington, DC 20420

Or

1100 First Street, NE, Area 501C,
Washington, DC 20007.

- Immediate contact information:

Telephone: 202-462-5311

FAX: 202-495-5486

E-Mail: Frequency.Management@va.gov

WEB: <http://vaww.netops.oit.va.gov/Frequency.asp>
(VA Intra-WEB Site only)

- (b) This Authority is vested in VA Manual MP-6, Part VIII – Telecommunications, Chapter Five – Audio, Radio and Television Services. A copy of this manual may be obtained from SMCS - 005OP2H3's WEB Site.
- (c) The design professional shall contact the following offices with questions, concerns, problems, design and installation assistance and for Official VA Telecommunications Systems resolutions, for:
 - Voice, telephone (PBX if used), telephone equipment and operators room (if used), telephone user equipment and related TIP situations:
 - I.** OI&T's Telecommunications Voice Engineering (TVE - 005OP2H2), North Carolina Office (919-382-8848).
 - II.** Data, VoIP, LAN, WAN and their TIP situations: OI&T's Executive Director for Field Operations (FO - 005OP), VACO Office (727-502-1379).
 - III.** VHA Equipment, Systems, Fire and Safety and other VHA requirements: VHA's Center for Engineering, Patient and Hospital Safety (CEOSH):
 - i. VACO (202-632-7888),
 - ii. Philadelphia Office (412-999-1321), or
 - iii. St Louis (Jefferson Barracks) Office (314-894-6100).

1.4 ABBREVIATIONS AND ACRONYMS

Abbreviations and Acronyms used in this document may be found in CFM master specification section 27 05 11 w REFERENCES.

(Refer to <http://www.cfm.va.gov/til/>)

CHAPTER 1: GENERAL REQUIREMENTS

1.5 COORDINATION

Coordinating planning and designing work with the architectural, structural, civil, site, sanitary, electrical, mechanical, fire protection, and sustainable (e.g. ANSI / TIA-4994-2015, Sustainable Technology Environments Program (STEP), U.S. Green Building Council Leadership in Energy and Environmental Design (LEED), Green Globes designs, as applicable are the design professional's responsibility. Provide distinct focus to concealed, underground areas, and site utility coordination.

1.5.1 SERVICE PROVIDER COORDINATION

- (a) Coordinating requirements with the local service provider(s) for projects requiring new, replacement, or expansion of existing telecommunications service is the design professional's responsibility. The Contractor's scope of work, as it relates to the telecommunications service, is to be detailed in the Construction Documents.
- (b) Forward copies of all correspondence and minutes of meetings with service provider's representatives to the COR regarding negotiations for new services or making changes to the existing services.
- (c) For renovations of and additions to existing buildings, the design professionals **must investigate** the existing infrastructure and determine whether sufficient capacity is available to accommodate the new requirements. If applicable, and inform the service provider of the new service requirements and additional lines.
- (d) Show major site distribution components, such as ductbanks, and maintenance holes, on the civil utility plans for coordination purposes.
- (e) **CAUTION: Wireless Service Providers (WSP) and Mobile Virtual Network Operators (MVNO) have been noted trying to establish their wireless systems in VA Facilities.**
 - These systems, when installed without VACO SMCS technical and spectrum frequency co-ordination, management oversight, may unknowingly affect VA's Critical Communication Systems. Namely: DAS In-building Wireless for Emergency Responders; Nurses Call / Code Blue for Safety of Life / Cardiac Arrest; EVNS Emergency Notification for Patient, Staff and Public Emergency Functions, etc. (see **Paragraphs 6.1.1** and **7.2.5.2**); especially, when noted using FCC Part 15, Unlicensed Radio Equipment for Government use.
 - WSP's and MVNO's installations, within VA Facilities, require Facility Contracting Office (FCO) Project Management Oversight. The FCO is the only Facility Office that can legally commit the government; and, SMCS is VA's AHJ for FMS Special Communications Systems. Contact their WEB Site for assignment of technical specialist(s) for project assistance, technical reviews and copies of Official FAA, FCC, GSA and VA MOU and Risk Assessment Forms that must be accomplished for

CHAPTER 1: GENERAL REQUIREMENTS

each wireless system (<http://vaww.netops.oit.va.gov/Frequency.asp>).
(VA Intra-WEB Site only)

- **Unauthorized wireless systems discovered during site visits shall be noted, documented and all discovered information turned over to VA's OSP Investigative Services, thru appropriate FCO(s), for resolution.**

1.5.2 PRE-DESIGN SITE SURVEY

The design professional shall perform the following tasks for renovations of and/or additions to existing buildings and all new construction:

- (a) Services Monitoring:** Investigate the existing systems and determine whether sufficient capacity is available to provide the appropriate level of services.
- (b) Existing Telecommunications Installation:** Investigate ***all existing*** telecommunications installations such as existing concealed conduit runs, conduit, cable, cable termination types/sizes, telecommunications and systems equipment locations, etc., which potentially impact the new installation.

1.6 VA DESIGN CRITERIA

Pertinent standards of VA's Office of Construction and Facilities Management are found in their Technical Information Library (TIL). Some of the major standards are:

1.6.1 MASTER SPECIFICATIONS (PG-18-1)

- (a)** Department of Veterans Affairs Office of Construction & Facilities Management (CFM) Master Construction Specifications, are located in TIL, and apply to all VA Projects: <http://www.cfm.va.gov/TIL/spec.asp>
- (b)** Master Construction Specifications specifically edited for use on VA National Cemetery Administration (NCA) construction projects are located at: <http://www.cfm.va.gov/til/NCAspec.asp>
- (c)** Veterans Benefit Administration (VBA) –Contact VBA's ADS' VACO Office (202-461-9300) for assistance if a VBA Facility is included in the project.
- (d) Purpose**

Defines a standardized method for the design professionals to ensure that the contractor provides equipment and systems that meet the design intent in terms of performance, quality, and cost. The Master Construction Specifications accomplish this by:

- Providing specific narrative descriptions of required equipment, salient elements, and system construction.
- Listing applicable standards and codes and references.
- Requiring individual submittal of equipment and systems for review and approval prior to contractor purchase.

CHAPTER 1: GENERAL REQUIREMENTS

1.6.2 DEFINING SPECIFIC INSTALLATION METHODS TO BE USED. DESIGN AND CONSTRUCTION PROCEDURES (PG-18-3)

Located in TIL and applies to all VA Projects:

(a) <http://www.cfm.va.gov/TIL/cPro.asp>

(b) **Purpose**

Establishes minimum consistent design/construction practices. The Procedures accomplish this by:

- Referencing applicable codes and policies.
- Describing standard drawing formats.
- Listing security strategies.

1.6.3 INCLUDING MISCELLANEOUS DESIGN DETAILS. NATIONAL CAD STANDARD, VHA APPLICATION GUIDE & STANDARD DETAILS (PG-18-4)

(a) Located in TIL and applies to all VA Projects:

<http://www.cfm.va.gov/TIL/sDetail.asp>

(b) **Purpose**

Adopts the NIBS National CAD Standard and establishes VA-specific drafting standards for the preparation of design and construction documents; and the guide provides utility and sheet template files and standard construction details, organized by discipline, for use in design and construction documents for VA projects.

1.6.4 EQUIPMENT REFERENCE MANUAL (PG-18-5)

(a) Located in TIL and applies to all VA Projects:

<http://www.cfm.va.gov/TIL/equip.asp>

(b) **Purpose**

Provides information for planning and developing requirements for contractor purchased and installed equipment for VA construction projects.

1.6.5 DESIGN MANUALS (PG-18-10)

(a) Located in TIL and applies to all VA Projects:

<http://www.cfm.va.gov/til/dManual.asp>

(b) **Purpose**

Conveys the general and specific VA design philosophy for medical and support facilities. The Manuals accomplish this by:

- **Explaining specific design methodologies.**
- **Listing acceptable system types.**
- **Codifying certain code interpretations.**

CHAPTER 1: GENERAL REQUIRMENTS

- **Listing values for design parameters.**
- **Referencing certain sections of the Master Specification and Standard Details.**
- **Containing examples of certain design elements.**
(**Note:** The design professional shall submit to VA a list of Design Manuals along with the TIL posted dates that were in effect on the date of contract award)

1.6.5.1 ELECTRICAL DESIGN MANUAL (EDM)

- (a) Located in TIL and applies to all VA Projects:

<http://www.cfm.va.gov/til/dGuide.asp>

(b) **Purpose**

Provides the design professional with specific layout templates and equipment lists for all types of spaces/uses, and specific design parameters for electrical and mechanical service. The Design Manual accomplishes this by:

- Publishing design narrative.
- Including functional diagrams.
- Listing standards.

1.6.5.2 PHYSICAL SECURITY DESIGN MANUAL (PSDM) FOR VA FACILITIES - MISSION CRITICAL FACILITIES & LIFE SAFETY PROTECTED FACILITIES

- (a) Located in TIL applies and to all VA projects:

<http://www.cfm.va.gov/til/spclrqmts.asp#phs>

(b) **Purpose**

Sets physical security standards for facilities required to continue operation during a natural or man-made extreme event and for facilities that are required to protect the life safety of patients and staff in an emergency. The Manuals accomplish this by:

- Setting objectives for physical security.
- Providing strategies for use in design and construction to provide protection to VA facilities.
- Providing cost-effective design criteria.

CHAPTER 1: GENERAL REQUIREMENTS

1.6.5.3 FIRE PROTECTION DESIGN MANUAL

(a) Located in TIL and applies to all VA Projects:
<http://www.cfm.va.gov/til/spclRqmts.asp#FS>

(b) **Purpose**

Provides fire protection design criteria, including fire alarm requirements.

1.6.6 VA DIRECTIVE 0730 – VA SECURITY AND LAW ENFORCEMENT HANDBOOK

(a) Located in the TIL and applies to all VA Projects:
<http://www.cfm.va.gov/til/spclRqmts.asp#PHSPurpose>

(b) Provides the design professional with physical security standards for all types of spaces/uses, and specific design parameters for electrical and mechanical service. Design must conform to NFPA Life Safety Code 101.

1.6.7 DESIGN GUIDES (PG-18-12)

(a) Located in TIL and applies to all VA Projects:
<http://www.cfm.va.gov/til/dGuide.asp>

(b) **Purpose**

Provides the design professional with specific layout templates and medical equipment lists for all types of spaces/uses, and specific design parameters for structural, electrical, and mechanical service. The Design Guides accomplish this by:

- Publishing design narrative.
- Including functional diagrams and layout plates.
- Listing standards.

1.6.7.1 OFFICE OF INFORMATION & TECHNOLOGY DESIGN GUIDE (OI&T – DG)

(a) Located in TIL and applies to all VA Projects:
<http://www.cfm.va.gov/til/dguide/dgOIT.pdf>

(b) **Purpose**

Provides the design professional specific layout templates for OI&T spaces and specific design parameters for electrical and mechanical service. The Design Guides accomplishes this by:

- Publishing design considerations.
- Including functional diagrams.

1.6.7.2 PROVIDING DESIGN GUIDE PLATES.NATIONAL CEMETERY ADMINISTRATION NETWORK CABLING SPECIFICATIONS

(a) Located in NCA Design & Construction Criteria:
<http://www.cfm.va.gov/til/nca.asp>

CHAPTER 1: GENERAL REQUIRMENTS

(b) Purpose

Provides cable and installation specifications for local area networks in VA National Cemetery administration and maintenance buildings.

1.6.7.3 DESIGN SUBMISSION REQUIREMENTS (PG-18-15)

(a) Located in Architect/Engineer Information and applies to all VA Projects:
<http://www.cfm.va.gov/til/aeDesSubReq.asp>

(b) Purpose

Provides a staged listing of tasks in various design categories to define the design professional's scope in order to ensure thorough and timely completion of the final design package and bid documents. The Instructions accomplish this by:

- Progressively listing tasks as Schematic, Design Development, and Construction Documents stages.
- Requiring task completion and submission for each stage according to a Critical Path Method (CPM) calendar.
- Implementation of a QA/QC process to ensure a quality design product.
- Requiring life-cycle analysis of alternatives in order to optimize the design/cost tradeoff.
- Listing and detailing all the drawings, calculations, and specifications required for a complete design package.
- Indicating the final distribution of bid documents.

1.6.8 ARCHITECT/ENGINEER REVIEW CHECKLIST

(a) Located in TIL and applies to all VA Projects:
<http://www.cfm.va.gov/til/projReq.asp>

(b) Purpose

Provides the VA Peer Reviewer with a minimum list of critical items, which must be included in each A/E submission. The Checklist accomplishes this by:

- Referring to all applicable VA design tools which apply to the specific project.
- Detailing certain Life Safety and coordination requirements.

CHAPTER 1: GENERAL REQUIRMENTS

1.6.8.1 DESIGN ALERTS

(a) Located in TIL and applies to all VA Projects:
<http://www.cfm.va.gov/til/alert.asp>

(b) **Purpose**

Communicates current design issues and solutions. The Design Alerts accomplish this by:

- Publishing periodic alert memos.
- Summarizing design solutions.

1.6.8.2 QUALITY ALERTS

(a) Located in TIL and applies to all VA projects:
<http://www.cfm.va.gov/til/alert.asp#qalert>

(b) **Purpose**

Communicates quality deficiencies from recent A/E design submissions. The Quality Alerts accomplish this by:

- Publishing checklists of design details often missed.
- Including references to technical resources.

1.6.9 COST ESTIMATING MANUAL

(a) Located in Technical Information Library and applies to all VA Projects:
<http://www.cfm.va.gov/cost/>

(b) **Purpose**

Conveys the general and specific VA cost estimating philosophy for medical facilities. The Manual accomplishes this by:

- Explaining specific estimating methodologies.
- Presenting examples of certain design elements.

1.6.10 SUSTAINABLE DESIGN AND ENERGY REDUCTION MANUAL

(a) Located in TIL and applies to all VA Projects:
<http://www.cfm.va.gov/til/sustain.asp>

(b) **Purpose**

Identifies the seven sustainability goals outlined in the Federal Mandates, and maps each goal to the appropriate LEED strategy for implementation. Possible methods to achieve the goals, budget considerations, case studies, and checklists are also included. The Manual accomplishes this by:

- Prescribing the use of integrated design practices.
- Providing strategies for optimization of energy performance.
- Providing strategies for protection and conservation of water resources.

CHAPTER 1: GENERAL REQUIREMENTS

- Providing strategies for enhancement of indoor environmental quality.
- Providing strategies for reduction of environmental impact of materials.

1.6.11 SEISMIC DESIGN REQUIREMENTS (H-18-8)

(a) Located in TIL and applies to all VA Projects:
<http://www.cfm.va.gov/til/seismic.asp>

(b) **Purpose**

Establishes policies to ensure that all facilities identified as essential are designed to remain operational after a seismic event.

1.6.12 VA HOSPITAL BUILDING SYSTEM (VAHBS)

(a) The VA Hospital Building System is a methodology based on a modular concept for planning, designing, and constructing hospitals.

(b) The methodology has been used nationwide with success in capital and operating cost containment, shortened delivery schedules, and improved space utilization flexibility. All new and replacement VA hospital buildings should use the VAHBS system. Also consider using this system for major additions to existing hospitals where future adaptability is an important factor.

(c) The design professional will find that systems schematic/design development efforts will occur much earlier in the overall planning/design process, due to the modular concept. Equipment selection and sizing should be evaluated as soon as the size and number of modules is determined.

(d) See VHA Program Guide PG-18-3, Design and Construction Procedures, Topic 3, VA Hospital Building System for further guidance. The complete reference for the VAHBS is contained in the 1976 Development Study (called the Redbook) and the 2006 Supplement.

1.6.13 COMPUTER AIDED FACILITIES MANAGEMENT REQUIREMENTS (CAFME)

VA intends to implement Computer Aided Facility Management systems for new and replacement hospital construction, and in all existing hospitals, as feasible. The CAFME concept requires that all pertinent data regarding a facility be contained in a master digital database, accessible by facilities personnel at their workstations for use in operations, energy/cost management, and maintenance, and for planning modifications in facility infrastructure due to space utilization changes.

1.6.14 VETERANS BENEFITS ADMINISTRATION; VBA INFORMATION SECURITY PROGRAM, VBA IRM DIRECTIVE NO. 5.00.01

(a) **Located at:**

<http://www.benefits.va.gov/warms/docs/admin20m/directive/dir50001.doc>

CHAPTER 1: GENERAL REQUIREMENTS

(b) Purpose

The VBA Information Security Program (ISP) defines controls for providing cost-effective protection of VBA automated information systems and telecommunications resources from unauthorized access, disclosure, modification, destruction or misuse.

1.7 OTHER DESIGN CRITERIA

1.7.1 ENERGY CONSERVATION

The need to conserve energy is mandated by the Federal Government by Executive Order and by Law enacted by Congress. In addition, 19 Federal Agencies have signed a Memorandum of Understanding (MOU) outlining specific goals and targets for energy conservation and sustainable design. VA is one of the signatory agencies. In the following paragraphs, references and details of various requirements are given.

1.7.2 DOE INTERIM FINAL RULE

- (a)** In the Federal Register (Volume 71, No. 232), dated December 4, 2006, the Department of Energy (DOE) issued mandatory energy conservation guidelines, as the interim final rule for implementing provisions in the Energy Policy Act (EPACT 2005). EXECUTIVE ORDER 13423 DATED JANUARY 26, 2007
- (b)** Mandatory energy conservation requirements are also published in the above Executive Order. The MOU is mentioned in Section 2, paragraph f of the Executive Order. The MOU was signed under the Federal Leadership in High Performance and Sustainable Buildings.

1.7.3 ADDITIONAL MEASURES (MOU)

The MOU also addresses related issues, such as commissioning and measurement and verification. These issues are described below

(a) COMMISSIONING

Employ total building commissioning practices tailored to the size and complexity of the building and its system components in order to verify performance of building components and systems and help ensure that design requirements are met. This should include a designated commissioning authority, the inclusion of commissioning requirements in construction documents, a commissioning plan, verification of the installation and performance of systems to be commissioned, and a commissioning report.

(b) APPROVED PROJECT (or CONTRACT) DEVIATIONS

- VA Administrations require their Official MOU(s) and / or Risk Assessment Form(s) to be generated documenting official approved project change and deviations falling within their purview. Contact SMCS 005OP2H3 (Re [Paragraph 1.3](#)) for FAA, FCC, GSA, OI&T approved MOU and Risk Assessment Sample Forms. If CFM requires

CHAPTER 1: GENERAL REQUIREMENTS

other project documentation, the CFM PM should contact SMCS with required documentation procedure(s) along with contract approved sample forms.

1.8 APPLICABLE CODES AND STANDARDS

1.8.1 GENERAL

- (a) Use the latest edition of Codes, Standards and Executive Orders as a basis of design. Refer to PG-18-3, Topic 1, Codes, Standards and Executive Orders.
- (b) Located at: <http://www.cfm.va.gov/TIL/cPro.asp>
- (c) Unless otherwise indicated by VA criteria, use the Codes and Standards of the following organizations:

1.8.1.1 FEDERAL COMMUNICATIONS COMMISSION, (FCC) CFR, TITLE 47:

- (a) Part 15 Restrictions of use for Part 15 listed RF Equipment in Safety of Life Emergency Functions and Equipment Locations. FCC Part 15 equipment or system is not allowed for performing “safety of life functions.”
- (b) Part 47 - Chapter A, Paragraphs 6.1-6.23, Access to Telecommunications Service, Telecommunications Equipment and Customer Premises Equipment.
- (c) Part 58 - Television Broadcast Service.
- (d) Part 73 - Radio and Television Broadcast Rules.
- (e) Part 90 - Rules and Regulations, Appendix C.
- (f) Form 854 Antenna Structure Registration.
- (g) Chapter XXIII - National Telecommunications and Information Administration (NTIA, P/O Commerce, Chapter XXIII) the ‘Red Book’– Chapters 7, 8 & 9 compliments CFR, Title 47, FCC Part 15, RF Restriction of Use and Compliance in “Safety of Life” Functions & Locations

1.8.1.2 US DEPARTMENT OF COMMERCE/NATIONAL INSTITUTE OF STANDARDS TECHNOLOGY (NIST)

- (a) FIPS PUB 1-1 - Telecommunications Information Exchange.
- (b) FIPS PUB 100/1 - Interface between Data Terminal Equipment (DTE) Circuit Terminating Equipment for operation with Packet Switched Networks, or Between Two DTEs, by Dedicated Circuit.
- (c) FIPS PUB 140/2 - Telecommunications Information Security Algorithms.
- (d) FIPS PUB 143 - General Purpose 37 Position Interface between DTE

CHAPTER 1: GENERAL REQUIREMENTS

and Data Circuit Terminating Equipment.

- (e) FIPS 160/2 - Electronic Data Interchange (EDI),
- (f) FIPS 175 - Federal Building Standard for Telecommunications Pathway and Spaces
- (g) FIPS 191 - Guideline for the Analysis of Local Area Network Security
- (h) FIPS 197 - Advanced Encryption Standard (AES),
- (i) FIPS 199 - Standards for Security Categorization of Federal Information and Information Systems, and
- (j) FIPS 201-2 - Personal Identity Verification (PIV) of Federal Employees and Contractors

1.8.1.3 UNITED STATES DEPARTMENT OF COMMERCE/NATIONAL TELECOMMUNICATIONS AND INFORMATION ADMINISTRATION (NTIA):

Manual of Regulations and Procedures for Federal Radio Frequency Management (aka “The Red Book”).

1.8.1.4 US DEPARTMENT OF HEALTH AND HUMAN SERVICES:

The Health Insurance Portability and Accountability Act of 1996 (HIPAA) Privacy, Security and Breach Notification Rules

1.8.1.5 US DEPARTMENT OF JUSTICE:

2010 Americans with Disabilities Act Standards for Accessible Design (ADAAD).

1.8.1.6 US DEPARTMENT OF LABOR, (DOL) - PUBLIC LAW 426-62 – CFR, TITLE 29, PART 1910, CHAPTER XVII - OCCUPATIONAL SAFETY AND HEALTH ADMINISTRATION (OSHA), OCCUPATIONAL SAFETY AND HEALTH STANDARDS):

- (a) Subpart 7 - Approved NRTLs (located at):
<https://www.osha.gov/dts/otpca/nrtl/nrtllist.html>
- (b) Subpart 35 - Compliance with NFPA 101, Life Safety Code,
- (c) Subpart 36 - Design and construction requirements for exit routes
- (d) Subpart 268 - Telecommunications
- (e) Subpart 305 - Wiring methods, components, and equipment for general use
- (f) Subpart 508 - Americans with Disabilities Act Accessibility Guidelines lists the technical requirement for accessibility to buildings and facilities by individuals with disabilities.

CHAPTER 1: GENERAL REQUIREMENTS

1.8.1.7 US DEPARTMENT OF TRANSPORTATION, (DOT) - PUBLIC LAW 85-625, CFR, TITLE 49, PART 1, SUBPART C – FEDERAL AVIATION ADMINISTRATION (FAA):

- (a) AC 110/460-ID & AC 707 / 460-2E – Advisory Circulars Standards for Construction of Antenna Towers.
- (b) 7450 and 7460-2 – Antenna Construction Registration Forms.

1.8.1.8 US DEPARTMENT OF VETERANS AFFAIRS (VA) - OFFICE OF TELECOMMUNICATIONS (OI&T):

1.8.1.8.1 MP-6, PART VIII, CHAPTER 5, AUDIO, RADIO AND TELEVISION (AND COMSEC) COMMUNICATIONS SYSTEMS:

(a) Spectrum Management and COMSEC Service (SMCS), AHJ for:

- CoG, “Continuance of Government” communications guidelines and compliance.
- COMSEC, “VA wide co-ordination and control of security / classified communication assets.”
- COOP, “Continuance of Operations” emergency communications guidelines and compliance.
- FAA, FCC, and US Department of Commerce National Telecommunications and Information Administration, “VA wide RF Co-ordination, Compliance and Licensing.”
- Low Voltage Special Communications Systems “Design, Engineering, Construction Contract Specifications and Drawings Conformity, Proof of Performance Testing, VA Compliance and Life Safety Certification(s) for CFM and VA Facility Low Voltage Special Communications Projects (except Fire Alarm, Telephone and Data Systems).”
- SATCOM, “Satellite Communications” guidelines and compliance, and Security and Law Enforcement Systems – “Coordinates the Design, Engineering, Construction Contract Specifications and Drawings Conformity, Proof of Performance Testing, VA Compliance, DEA and Public Safety Certification(s) for CFM and VA Facility Security Low Voltage Special Communications and Physical Security Projects.
- Wireless and Handheld Device(s), “guidelines and compliance,”
- Handbook 6100 – Telecommunications: Cyber and Information Security Office of Cyber and Information Security, and Handbook 6330, Directives Management Procedures.

1.8.1.8.2 VETERANS HEALTH ADMINISTRATION’S (VHA) NATIONAL CENTER FOR PATIENT SAFETY:

- (a) Contact VHA’s CEOSH (See Paragraph 1.3) for VHA related issues.
- (b) Including: VA Directive 7700 - Warning System, Failure of Medical Alarm

CHAPTER 1: GENERAL REQUIRMENTS

Systems using Paging Technology to Notify
Clinical Staff, July 2004.

1.8.1.8.3 OFFICE OF SECURITY AND LAW ENFORCEMENT:

- (a) VA Directive 0730 and Homeland Security Directive (HSPD)-12.

1.8.1.9 NRTL STANDARDS:

Refer to <https://www.osha.gov/dts/otpca/nrtl/index.html>.

1.8.2 INDUSTRY STANDARDS:

1.8.2.1 AMERICAN INSTITUTE OF ARCHITECTS (AIA):

2006 Guidelines for Design & Construction of Health Care Facilities.

1.8.2.2 BUILDING INDUSTRY CONSULTING SERVICE INTERNATIONAL, INC. (BICSI®):

- (a) Telecommunications Distribution Methods Manual (TDMM).
- (b) Outside Plant Design Reference Manual (OSPDRM).
- (c) ANSI/BICSI 002 - Data Center Design and Implementation Best Practices.
- (d) ANSI/BICSI 003 - Building Information Modeling (BIM) Practices for Information Technology Systems
- (e) ANSI/BICSI 004 - Information Technology Systems Design and Implementation Best Practices for Healthcare Institutions and Facilities
- (f) ANSI/NECA/BICSI 568 Standard for Installing Commercial Building Telecommunications Cabling.
- (g) NECA/BICSI 607 - Standard for Telecommunications Bonding and Grounding Planning and Installation Methods for Commercial Buildings.
- (h) ANSI/BICSI 005 - Electronic Safety and Security (ESS) System Design and Implementation Best Practices.
- (i) Electronic Safety and Security Design Reference Manual (ESSDRM).
- (j) Information Technology Systems Installation Methods Manual (ITSIMM)

1.8.2.3 FACILITY GUIDELINES INSTITUTE:

2010 Guidelines for Design and Construction of Health Care Facilities.

1.8.2.4 THE FIBER OPTIC ASSOCIATION, INC.:

OSP Fiber Optics Civil Works Guide.

CHAPTER 1: GENERAL REQUIREMENTS

1.8.2.5 INTERNATIONAL ORGANIZATION FOR STANDARDIZATION (ISO):

- (a) Standards for Protocols and Interfaces that include Open System Interconnections (OSI)
- (b) ISO/TR 21730 - Use of mobile wireless communication and computing technology in healthcare facilities - Recommendations for electromagnetic compatibility (management of unintentional electromagnetic interference) with medical devices.

1.8.2.6 NATIONAL FIRE PROTECTION ASSOCIATION (NFPA):

- (a) NFPA 70 - **National** Electrical Code® (NEC)
- (b) NFPA 75 - Standard for the Fire Protection of Information Technological Equipment.
- (c) NFPA 99 - Health Care Facilities Code.
- (d) NFPA101 - Life Safety Code.
- (e) NFPA 780 - Standard for the Installation of Lightning Protection Systems.
- (f) NFPA 1221 - Standard for the Installation, Maintenance, and Use of Emergency Services Communications Systems.
- (g) NFPA 5000 - Building Construction and Safety Code.

1.8.2.7 NATIONAL INSTITUTE OF BUILDING SCIENCES, WHOLE BUILDING DESIGN GUIDE:

- (a) The design professional must contact the DoD Unified Facilities Criteria (UFC) program, <http://dod.wbdg.org/> (VA is a Silver Member), to obtain an approved federal based and formatted communications technical specification if one that is needed does not appear on CFM's TIL.
- (b) If the Unified Facilities Guide Specifications (UFGS) Site does not have an appropriate specification; the design professional shall develop the needed specification, provide it to SMCS 005OP2H3 (through CFM's PM) for approval; who, in turn will provide the document to CFM's Director, Facilities Standards Service (through CFM's PM) for approval, assignment of an official VA CFM designation number and enter it into the project official documents.
- (c) Contact UFGS at: www.ubdg.com and SMCC 005OP2H3 (**Re Paragraph 1.3**).

1.8.2.8 TELECOMMUNICATIONS INDUSTRY ASSOCIATION (TIA):

- (a) TIA-120 Series - Telecommunications Land Mobile communications (APCO/Project 25).
- (b) TIA-155 - Guidelines for the Assessment and Mitigation of Installed Category 6 Cabling to Support 10GBASE-T.
- (c) TIA TSB-162-A - Telecommunications Cabling Guidelines for Wireless

CHAPTER 1: GENERAL REQUIRMENTS

- Access Points.
- (d) TIA-222 - Structural Standard for Antenna Supporting Structures and Antennas.
 - (e) TIA-472D000-B - Fiber Optic Communications Cable for Outside Plant Use.
 - (f) TIA-568 - Revision/Edition: C Commercial Building Telecommunications Cabling Standard Set:
 - TIA-568-C.0-2 Generic Telecommunications Cabling for Customer Premises,
 - TIA-568-C.1-1 - Commercial Building Telecommunications Cabling Standard Part 1: General Requirements,
 - TIA-568-C.2 - Commercial Building Telecommunications Cabling Standard—Part 2: Balanced Twisted Pair Cabling Components,
 - TIA-568-C.3-1 - Optical Fiber Cabling Components Standard, and
 - TIA-568-C.4- Broadband Coaxial Cabling and Components Standard (with addendums and errata).
 - (g) **TIA-569 Revision/Edition C - TELECOMMUNICATIONS PATHWAYS AND SPACES.**
 - (h) **TIA/EIA-590-A** - Standard for Physical Location and Protection of Below Ground Fiber Optic Cable Plant.
 - (i) **ANSI/TIA-606-B** -Administration Standard for Telecommunications Infrastructure.
 - (j) **TIA-607-B** - Generic Telecommunications Bonding and Grounding (Earthing) For Customer Premises.
 - (k) **ANSI/TIA-758-B** - Customer-owned Outside Plant Telecommunications Infrastructure Standard.
 - (l) **ANSI/TIA-862-A** - Building Automation Systems Cabling Standard.
 - (m) **TIA-942-A** - Telecommunications Infrastructure Standard for Data Centers.
 - (n) **TIA-1179** - Healthcare Facility Telecommunications Infrastructure Standard.
 - (o) **ANSI/TIA-4994** -Standard for Sustainable Information Communications Technology

1.8.2.9 THE JOINT COMMISSION:

Environment of Care: Books and Manuals.

CHAPTER 1: GENERAL REQUIREMENTS

1.8.3 LOCAL CODES AND CONDITIONS

The design professional must bring local and regional climatic and geographic conditions, and provisions of local building codes that are significantly different from the codes and standards listed above to the attention of VA and provide specific information on how the proposed design reflects these conditions and codes. Of particular focus are local codes, code amendments, and conditions related to coastal, hurricane-prone, arctic, or seismically-active regions, or other climatic or regional conditions that warrant additional measures to protect the integrity of systems.

1.8.3.1 LOCAL UTILITY

The design professional must follow the rules and regulations of the local service provider, where applicable.

1.9 DESIGN REQUIREMENTS

- (a) All conductors for the TIP telecommunications distribution system components shall be copper and approved fiber optic cables.
- (b) The design professional shall determine probable cabinet, rack and equipment sizes from several manufacturers, and ascertain that the telecommunications rooms are sufficiently sized. Consider largest and/or heaviest dimensions and weights so that working clearance requirements, space for future installations, and structural requirements are satisfied.
- (c) Specifications (See [Paragraph 7.2](#) for additional requirements and information):
 - VA Master Specifications have been developed for typical telecommunications and systems work. The appropriate sections shall be edited to meet the project scope of work and specific project requirements.
 - The design professional shall carefully coordinate specifications with the drawings so that all work required by the drawings is included in the specifications. Specification content that does not apply to the project shall be deleted.
 - The design professional shall develop specifications for any system or equipment **not addressed** by VA's Master Specifications by using the DoD Unified Facilities Criteria (UFC) Program's, Unified Facilities Guide Specifications (UFGS), supported by National Institute of Building Sciences, located at:
http://www.wbdg.org/ccb/browse_cat.php?c=3, and approved by AHJ SMCS.

CHAPTER 1: GENERAL REQUIREMENTS

- **VA's Master Telecommunications Specifications shall govern if there is a conflict between them and the Project Drawings.**

1.9.1 CRITERIA UNIQUE TO VA

1.9.1.1 DRAWINGS

Refer to VA Design and Construction Procedures (PG-18-3), Topic 2 – Drawings, and the VA NCS Application Guide, for general drawing requirements.

- (a) Consolidate notes and place them on the right-hand side of the sheet.
- (d) Show scale, compass point, orientation, key plan, title, column grids and numbers, match lines, room numbers, and titles corresponding to the architectural drawings.
- (c) Provide large-scale (minimum 1/4"=1') partial plans for areas such as Main Computer Room, Telephone Equipment/Operator Room, Telecommunications Rooms, and Network Operations Room, DEMARC, Antenna Head End Room, Police Control / Operation Rooms, Emergency Communications Control Room and Emergency Management Operations Rooms (if not a part of the Emergency Communications Control Room). Contact, Spectrum Management and COMSEC Service (SMCS 005OP2H3) for complete list.
- (d) Provide 1/4-inch scale details of special equipment spaces, such as Laboratories, Radiology, Dietetic Areas, Surgical Rooms, and Telecommunications Rooms.
- (e) Show pathways for all backbone cables on plans as close to the location of final installations as possible to avoid field installation conflicts likely to cause costly construction change orders and delays. Show conduit path in parallel with the building outline, and coordinate with existing field conditions and installations of electrical, mechanical and other systems. Show appropriate number of pullboxes located at appropriate distances on conduit runs sized to facilitate efficient installation and maintenance of cables.
- (f) Provide VA's AHJ (SMCS-005OP2H3) two compact disks (CD) containing telecommunications drawings for each Project Formal review (Paragraph 1.3).
- (g) At a minimum, the construction documents shall contain diagrams of the following systems:
 - Telecommunications Distribution (Riser Diagram).
 - Essential Telecommunications Systems, Controls and Operation (Riser Diagram).
 - Sequences of Operation.
 - Grounding and bonding System.
 - Primary Systems Backbone Distribution Pathways (One-line Diagram).

CHAPTER 1: GENERAL REQUIREMENTS

- Telephone, Data, Nurse Call, Emergency Call, Duress Alarm, PA, MATV, CCTV, IC, DAS, Intrusion Detection, Access Control (PACS), and Other Signal Systems (Riser Diagrams).

1.9.1.2 SEQUENCE OF SYSTEMS DRAWINGS

- (a) Symbols and Abbreviations.
- (b) Demolition Plans.
- (c) Telecommunications Site Plan(s).
- (d) Audio/Visual Systems Plans.
- (e) Nurse Call Plans.
- (f) Telecommunications Plans.
- (g) Signal or Other Systems Plans.
 - Electronic Security Plans.
 - Riser Diagrams.
 - Details.
 - Schedules.
- (h) Fire alarm systems are part of the Fire Protection discipline, and shall be shown on the Fire Protection Plans.
- (i) Signal Systems may be combined with Telecommunications Systems on projects with a minimal number of signal devices.

1.9.1.3 DRAWING ABBREVIATIONS AND SYMBOLS

- (a) Use only the abbreviations and symbols shown in the VA Standard Details (PG-18-4) and the VHA National CAD Standard Application Guide.
- (b) The VHA National CAD Standard Application Guide does not apply to National Cemetery Administration projects. Refer to National Cemetery System Computer-Aided Design and Drafting Standards Manual located in the Technical Information Library (TIL).

1.9.1.4 PROPRIETARY ITEMS

Do not use trade names or other indications that identify a product of an individual manufacturer on any project, unless specifically approved and as follows:

- (a) Where necessary to identify existing equipment.
- (b) Where an existing system is to be extended and competitive manufacturers cannot meet the performance or dimensional requirements.
- (c) Where required by a public utility or municipal system as a condition of its services, construction specifications developed by the design professional shall state this condition.

CHAPTER 1: GENERAL REQUIRMENTS

1.10 CALCULATIONS

1.10.1 GENERAL

- (a) It is the responsibility of the design professional to prepare and submit, or specify, calculations as required by the type of design work performed. Calculations shall justify size of each cable, raceway, and cable tray. It is the responsibility of the design professional to determine which calculations to perform and which calculations to specify for the contractor to perform. Not all calculation types shall be required for all projects. VA reserves the right to request additional calculations to suit the project.
- (b) The design professional shall submit the following calculations to VA spectrum analysis:
 - Internal
 - I Wireless (including ***ALL*** Wi-Fi) Systems transmitted/ received signal strength vs layout.
 - II Internal DAS layout; external transmitted/received signal strength.
 - III External RF radiation pattern; received signal strength.

CHAPTER 1: GENERAL REQUIREMENTS

External

- I Radio Telephone/Data Satellite transmitted/received signal strength.
- II External Broadcast/TVRO Satellite transmitted/received signal strength.
- III External V-SAT (Satellite) transmitted/received signal strength.
- IV Areas of Radio Frequency and Electro Magnetic Interference.
- V External Radio Paging radiation pattern.
- VI External M/W transmitted/received signal strength (if used).
- VII Internal/External MATV/CATV television received signal strength and outlet transmitted signal strength.

1.10.2 LOAD CALCULATIONS

Prepare and submit load calculations that justify the size of each UPS and battery bank. The method of calculation shall be clearly presented in the drawings, including all applicable diversity factors and non-coincident loads and their employment at various levels of the electrical system, as well as the capacity reserved for future load.

1.10.3 SEISMIC BRACING

1.10.3.1 REFERENCES

Refer to [H-18-8](#) "VA Seismic Design Requirements." ***Coordinate with the Structural Engineer so that seismic bracing is provided as required.***

1.10.3.2 DRAWINGS

Contract drawings shall show the detail methods of anchoring telecommunications equipment. Drawings shall include the size, number, and type of anchors and fasteners to be used to secure the equipment against the seismic forces and to meet codes. Calculations for equipment anchoring shall be performed by a registered structural engineer.

1.10.3.3 EQUIPMENT BRACING

Refer to Section 13 05 41 SEISMIC RESTRAINT REQUIREMENTS FOR NON-STRUCTURAL COMPONENTS for seismic bracing requirements. Typically, all telecommunications, and signal equipment and enclosures are to be seismically braced and anchored.

1.11 TRANSPORT SYSTEMS

Refer to PG-18-10, TRANSPORT SYSTEMS DESIGN MANUAL FOR HOSPITAL PROJECTS for requirements.

1.12 RENOVATION TO EXISTING SITES AND BUILDINGS

1.12.1 DRAWINGS

For renovation projects, separate demolition drawings are required for all areas involved in the project. Specific detailing of interfaces between renovated and existing-to-remain conditions shall be clearly indicated on the drawings. The design professional shall fully describe existing equipment affected by a

CHAPTER 1: GENERAL REQUIRMENTS

renovation project, including but not limited to existing equipment manufacturer, model, voltage, amperage, and A/C ratings, description, new devices installed, new cables terminated, etc.

1.12.2 MODIFICATION VERSUS REPLACEMENT

Where equipment must be modified to be physically utilized in a project, the following items must be evaluated:

- (a) Can the government look to one manufacturer for final responsibility of the modified equipment?
- (b) Is there a legitimate cost saving by modifying the existing equipment rather than installing new equipment? If yes, then modification should be considered.
- (c) What is the impact on operation and safety during and after construction?
- (d) Will the equipment retain a valid UL-listing after modification? If no, the equipment shall be replaced.

1.12.3 AGE AND PHYSICAL CONDITION

- (a) The length of time in service and physical condition of wiring, devices, and equipment shall be reviewed prior to considering reuse.
- (b) The equipment shall be capable of remaining in use for a minimum of five (5) years of additional life or having 60 percent of remaining life. If not, the equipment shall be replaced.
- (c) Where equipment has been in operation for a number of years, physical inspection of terminals, insulation, switching contacts, control wiring, etc., shall be performed by the design professional. The design professional shall make recommendations for use of the equipment to VA.

1.12.4 PARTS AVAILABILITY

- (a) After the design professional's site surveys, the availability of spare parts for existing equipment shall be determined.
- (b) Where the project involves extending an existing system but the existing equipment spare parts are not available, the design professional shall inform the VA COR in writing. Specific directions shall be requested at that time.

1.12.5 CONDUIT AND BOXES

- (a) Conduit and boxes shall be removed from existing walls that are to be demolished.
- (b) Conduit and boxes in existing walls that are to remain shall be cleaned of existing cable(s), abandoned in place (if not reused), the boxes shall be provided with blank covers, painted with "spare" signage and indicated on and update the Facility's TIP Drawings.

CHAPTER 1: GENERAL REQUIRMENTS

- (c) Conduit not intended for reuse in existing or new ceilings shall be removed back to the power, telecommunications, or signal system source from which it originates.
- (d) Conduit run in the existing concrete slab shall be sawed-cut off as it enters and exits the slab, and then sealed to prevent moisture access.

1.12.6 CONDUCTORS

All abandoned conductors or cables not deemed reusable shall be removed back to the telecommunications, or signal system source from which they originate.

1.12.7 WORK AREA OUTLETS

Remove devices that are not to be re-used. Cabling is to be removed in its entirety. Boxes shall be blanked.

1.12.8 PATCHPANELS AND PUNCHDOWN BLOCKS

Patchpanels and punchdown blocks may be installed in new or existing telecommunications rooms and telecommunications enclosures. Corridor-mounted patchpanels and punchdown blocks shall not be installed without specific approval from VA. Refer to other sections of this manual for requirements.

1.12.9 GOVERNMENT RETAINED EQUIPMENT (AKA GFE)

After consulting with the VA Medical Center, determine if the following items shall be retained by government:

- (a) Nurse Call System Components.
- (b) Telecommunications System Components.
- (c) SMS Systems Components.
- (d) Telecommunications System Components including TIP.
- (e) Components installed to provide temporary construction service that are not property of the Contractor.

1.12.10 CONTINUITY OF SERVICE

- (a) Services passing through areas of remodeling and / or construction shall be maintained throughout the construction period.
- (b) Provide temporary and / or modify existing telecommunications, and other services as required for construction-period Interim Life Safety measures.

1.12.11 COMPATIBILITY

Equipment and systems installed shall be fully compatible and functional with existing Facility components and systems to which it interfaces.

This page intentionally left blank.

CHAPTER 2: TABLE OF CONTENTS

CHAPTER 2: TABLE OF CONTENTS

2.0	RACEWAYS, PATHWAYS, WIREAYS, CABLE TRAYS, CABLE DUCTS, CONDUITS, BOXES AND EQUIPMENT	2-0
2.1	CABLE PATHWAYS.....	2-0
2.1.1	CONDUITS AND BOXES	2-0
2.2	HORIZONTAL CONDUITS.....	2-3
2.2.1	PARTITIONED CABLE TRAYS AND OPEN WIREWAYS	2-4
2.2.2	TELECOMMUNICATIONS CABLE DUCTS UNDER CELLULAR FLOORS... ..	2-4
2.3	VERTICAL RISERS	2-5
2.3.1	TELECOMMUNICATIONS OUTLETS (TCO)	2-5
2.4	DRAWINGS	2-6
2.5	CONCEALED AND EXPOSED CONDUITS.....	2-6
2.6	UNDERGROUND DUCTS AND CONDUITS	2-6
2.7	INDOOR CONDUITS AND PATHWAYS	2-7
2.8	SPARE CONDUITS.....	2-8
2.9	STAIRWELLS	2-8
2.10	UNDERFLOOR DUCT SYSTEMS	2-8
2.11	ROOMS REQUIRING UNIQUE CONDUIT ATTENTION	2-8
2.11.1	RADIOLOGY ROOMS	2-8
2.11.2	TELEPHONE EQUIPMENT ROOM (TER) and TELEPHONE OPERATOR's ROOM (IF REQUIRED) (Contact OI&T's TVE [Re Paragraph 1.3] for specific technical assistance in these voice/PBX environments).....	2-9
2.12	POKE-THRU, TELE-POWER POLE.....	2-10
2.13	ETHYLENE OXIDE STERILIZATION AREA.....	2-10
2.14	RATED CONSTRUCTION	2-10

CHAPTER 2: TABLE OF CONTENTS

This page intentionally left blank.

CHAPTER 2: RACEWAYS AND PATHWAYS

2.0 RACEWAYS, PATHWAYS, WIREAYS, CABLE TRAYS, CABLE DUCTS, CONDUITS, BOXES AND EQUIPMENT

2.1 CABLE PATHWAYS

This section describes cabling pathway requirements for telecommunications cables, and special telecommunications systems (hereinafter referred to as "Special Systems") wiring and cables for all VA facilities. Cable pathways and raceways shall incorporate sufficient capacity for Telecommunications and Special Telecommunications Systems cables.

- (a) Raceways - shall be as specified in PG-18-1, Master Specifications.
- (b) TIP cabling may be installed above suspended ceilings using wire basket cable trays when specifically approved on a case by case basis, in writing, by SMCS- 005OP3H3. Minimum size of wire basket tray shall be 150 mm [6 in.] wide, with 40 mm [1.5 in] high sidewalls, with internal partitions or approved cable bundling.
- (c) In hard ceiling areas, a raceway system, which may consist of a mixture of conduits and enclosed cable trays, is required.

2.1.1 CONDUITS AND BOXES

For system conduits, pull boxes, routing, termination, risers, horizontal runs, sizing, etc., follow industry standard requirements. Raceway definitions shall comply with NEC definitions.

2.1.1.1 CONDUITS MINIMUM REQUIREMENTS

- (a) Conduit from work area outlet to above accessible ceiling interior diameter shall be a minimum of 35 mm [1.25 inch].
- (b) Conduit runs shall be equipped with a pullbox (inside), or maintenance hole (outside), after two 90-degree bends or an accumulation of 120-degrees of total pathway deviations from a straight line between each point of access.
- (c) Conduits outside of buildings shall be waterproof and shall not exceed 122 M [400 ft.] between maintenance holes or pullboxes (not counting bend or traverse loss).
- (d) Conduits inside of buildings shall not exceed 30.48 M [100 ft.] between pullboxes or pull points.
- (e) For conduit diameters 53 mm [2 in.] or less, minimum bend radius shall be six times the internal diameter of conduit. For conduit diameters exceeding 53 mm [2 in.], conduit bend radius shall be 10 times internal diameter of conduit.
- (f) For conduit enclosing optical fiber cabling minimum conduit bend radius shall be 10 times internal diameter of conduit.
- (g) In interstitial spaces, route conduit to the nearest cable tray, cabinet, or rack.

CHAPTER 2: RACEWAYS AND PATHWAYS

- (h) Conduits of conductive materials shall be grounded.
- (i) Conduits shall be labeled at terminations for identification.
- (j) TIP cabling may be installed above suspended ceilings using wire basket cable trays when specifically approved on a case by case basis, in writing, by SMCS- 005OP3H3. Minimum size of wire basket tray shall be 150 mm [6 in.] wide, with 40 mm [1.5 in.] high sidewalls, with internal partitions or approved cable bundling.
- (k) In hard ceiling areas, a raceway system, which may consist of a mixture of conduits and enclosed cable trays, is required.

2.1.1.2 INTERCONNECTING CONDUIT REQUIREMENTS

- (a) The design professional may refer to the one-line drawing of suggested telecommunications topology in [APPENDIX A](#) for a graphical representation. The table 2-1 identifies the minimum conduit requirements for the TIP infrastructure.
- (b) Coordinate all conduit entrance locations with the facility staff and obtain written technical approval from SMCS-005OP2H3.
- (c) Conduit Use / Designation:

Table 2-1 Conduit Requirements

LOCATION A	LOCATION B	CONDUIT TYPE	QTY	SIZE
Service Provider Entrance A from street	Demarcation (Demarc) Room A	Direct burial PVC or HDPE	5 ^[1]	100 mm [4 inch]
Service Provider Entrance B	Demarc Room B	Direct burial PVC or HDPE	5 ^[1]	100 mm [4 inch]
Demarc Room A	Main Computer Room (ITPE1)	EMT	10 ^[2]	100 mm [4 inch]
Demarc Room B	ITPE1	EMT	10 ^[2]	100 mm [4 inch]
Demarc Room A	Antenna Headend Equipment Room (TEEQ1)	EMT	1	100 mm [4 inch]with four 25 mm [1 inch] innerducts
Demarc Room B	TEEQ1	EMT	1	100 mm [4 inch]with four 25 mm [1 inch] innerducts

CHAPTER 2: RACEWAYS AND PATHWAYS

LOCATION a	LOCATION B	CONDUIT TYPE	QTY	SIZE
ITPE1	Each TR Vertical Riser Stack on the MCR Floor	EMT	3 x Number of TRs in stack ^[4]	100 mm [4 inch]
ITPE1	Backup Computer Room (ITBU1)	EMT	6 ^[3]	100 mm [4 inch]
ITPE1	Telephone Operators Room (TEOR1)	EMT	1	100 mm [4 inch]
ITPE1	Police Control Room (PCR)	EMT	1	4 in [100 mm] with four 25 mm [1 inch] innerducts
ITPE1	TEEQ1	EMT	2	100 mm [4 inch]
ITPE1	Engineering Control Center (ECC)	EMT	1	100 mm [4 inch] with four 25 mm [1 inch] innerducts
ITPE1	Emergency Management Control Room (EMCR)	EMT	1	100 mm [4 inch] with four 25 mm [1 inch] innerducts
TR	TRs on same floor	EMT, Cable Tray	as required	Minimum cable tray size: 100 mm [4 inch] deep x 100 mm [4 inch] wide
TR	Next stacked TR	EMT (sleeves)	3 x Number of TRs above ^[4]	140 mm [6 inch]
TEEQ1	Roof or access to antennae	GRC (weather proofed)	2	75 mm [3 inch]
TEEQ1	Nearest TR	EMT	2	100 mm [4 inch]
TEEQ1	PCR	EMT	1	100 mm [4 inch] with four 25 mm [1 inch] innerducts
TEEQ1	Engineering Control Room (ECR) ^[5]	EMT	1	100 mm [4 inch] with four 25 mm [1 inch] innerducts
TEEQ1	Emergency Control Room (EMCR) ^[5]	EMT	1	100 mm [4 inch] with four 25 mm [1 inch] innerducts

CHAPTER 2: RACEWAYS AND PATHWAYS

NOTES

- [1] One (1) voice, one (1) data, one (1) special systems, one (1) security/emergency systems, and one (1) spare.
- [2] Ten (10) conduits from each Demarc Room to the Main Computer Room.
- [3] Two (2) voice, three (3) data & one (1) spare.
- [4] One (1) for OI&T and two (2) for FMS. The single OI&T conduit per TR shall contain:
 - Three (3) 2.54 cm [1-inch] innerducts (one for 12 strands single mode fiber; one for 24 strands laser optimized multi-mode fiber; one for 12 strands multi-mode fiber) and one (1) 100 pair copper 1.88 cm [0.74 inch] OD.
 - One (1) FMS/OI&T conduit per TR shall contain four (4) 2.54 cm [1-inch] innerducts (one for 12 strands single mode fiber, one for 24 strands laser optimized multi-mode fiber, one for 12 strands multi-mode fiber, and one spare). The other FMS conduit shall be spare.
- [5] ECR and EMCR may be combined if the facility doesn't have a designated OSP Emergency Management Control Center (EMCC) Command Location.
- (d) Coordinate all conduit entrance locations with the facility staff and obtain written technical approval from SMCS-005OP2H3.

2.2 HORIZONTAL CONDUITS

- (a) Conduit providing mechanical protection of cabling and forming an effective ground-fault current path must be installed from the cable distribution system, (i.e. cable tray or enclosed duct) to each TCO in patient care areas. Metal faceplates with a metal mounting screw bonding the faceplate to the metal outlet box connecting to the ground-fault current path shall be required. Corridors are not considered patient care areas. When cable tray or enclosed duct is not used, individual conduits should be installed from the TR to each outlet.
- (b) Maximum conduit fill ratio of 40 percent should be accommodated for when sizing conduit. No more than six, four-pair cables may be in a 35 mm [1-1/4 in.] conduit.
- (c) Conduit entries at pull boxes must be arranged so that cables passing through the box enter and exit at opposite sides of the box. Require conduit elbows that maintain cable bend radii for changes of direction.
- (d) Surface metal raceways are not acceptable and shall not be approved for wire or cable on the outside walls.
- (e) Conduit runs to and from backboards in a TR or interstitial space shall terminate at the top or bottom of the backboard. Conduits shall not cover the any portion of the backboard.

CHAPTER 2: RACEWAYS AND PATHWAYS

- (f) Horizontal runs of enclosed wireways (covered cable duct with closed covers) are not acceptable for above-ceiling applications. However, enclosed wireways are required in interstitial spaces.
- (g) Do not use flexible metal conduit for telecommunications cable except when installing floor-access boxes in a raised floor, where floor-access box must be relocated within a specified service area; and, ceiling-access boxes in dropped ceilings to allow proper positioning of the ceiling box and provide “safety suspension / protection in lieu of the required safety wire(s).”

2.2.1 PARTITIONED CABLE TRAYS AND OPEN WIREWAYS

- (a) Unless otherwise specified, install all system TIP wiring and cabling in approved telecommunications partitioned cable trays (or open wireways), as specifically approved by SMCS 005P2H3.
- (b) When permitted by NFPA, partitioned cable trays (or open wireways) may contain multiple telecommunications systems of like service. These combinations must be approved by SMCS 005P2H3 prior to the system design. The partitioned cable trays (or open wireways) must provide mechanical protection of the cables, and allow for separation of cables by their system function.
- (c) Open wireways or partitioned cable trays may be mounted vertically if they are attached to solid building structures and the wires or cables are protected, secured from falling from the tray, and separated from other systems.
- (d) Cable in interstitial spaces may be placed in individual conduit run(s) to meet unique and specific system design or structural requirement(s) with prior approval from SMCS 005OP2H3.
- (e) Cable tray may be used above accessible corridor ceilings for station cable in non-critical areas as long as each location’s egress and ingress signal processing and radiation and electromagnetic interference (EMI) properties are maintained as described herein and approved by SMCS 005OP2H3 prior to final system design.
- (f) The use of cable hangers, J-hooks, O-Rings, U-Clamps and other like items, *are not allowed* for Special Systems certified or listed for Critical, Life and Public Safety and Emergency Operations under any design condition or function (contact SMCS 005OP2H3 for clear definition and specific description of unacceptable items).

2.2.2 TELECOMMUNICATIONS CABLE DUCTS UNDER CELLULAR FLOORS

- (a) Cables installed below raised or accessed flooring (considered an air plenum) must be plenum-rated.
- (b) Underfloor cable duct and/or cellular floor installation shall be provided with appropriate TIP wire management.

CHAPTER 2: RACEWAYS AND PATHWAYS

- (c) All underfloor ducts or cellular floors must extend to wall partitions in rooms where installed.

2.3 VERTICAL RISERS

- (a) The main horizontal conduit runs from the MCR to each stacked TR shall be of the size, use, and count described in Table 2.1, and shall penetrate the TR floor and terminate 450 mm [18 in.] above finished floor (AFF). Each floor penetration shall be sleeved and sealed with approved firestopping compound regardless of whether filled with wire/cable.
- (b) Each TR ceiling and corresponding floor of the above stacked TR shall be provided with sleeved penetrations of the size, use, and count described in Table 2.1. Each penetration shall be sealed with approved firestopping compound regardless of whether filled with wire/cable.

2.3.1 TELECOMMUNICATIONS OUTLETS (TCO)

- (a) Outlet back boxes shall be 152 mm x 152 mm x 53.975 mm [4-11/16" x 4-11/16" x 2-1/8"] or 119.06 mm 119.06 mm x 53.975 [5" x 5" x 2-1/8"] that contain 35 mm [1-1/4"] conduit knock outs to allow EMT or specified conduit to terminate on them.
- (b) Work area TCOs shall be equipped with six port faceplates that cover the entire box without trim rings and include two active Category 5e (or better) RJ-45/11 jacks for voice (or telephone), and two active Category 5e (or better) RJ-45 jacks for data. Faceplate shall also provide space for the addition of one modular stainless steel LC fiber-optic jack and one female F coaxial cable jack.
 (NOTE: Design professional may substitute "SC" or "BNC" type, depending on system design.)
- (c) Unless otherwise specified, mounting heights for telecommunication outlets shall be as shown in Table 2-2.

Table 2-2 Telecommunications Outlets Mounting Height

AREA/FUNCTION	MOUNTING REQUIREMENTS
Pay station	1.1176 M [3 ft. 8 in] above finished floor (AFF)
Desk outlet	450 mm [18 inch] AFF
Special Use Areas	As required by design professional's design and approved by SMCS 005OP2H3

- (d) For Patient Bed Prefabricated Wall Units (PBPU), use the provided outlet box and conduit in order not to violate the PBPU's NRTL (e.g., UL) Medical/Life Safety Certification. ***Modifications to the PBPU must***

CHAPTER 2: RACEWAYS AND PATHWAYS

be approved by the manufacturer. Violations of the units' NRTL (e.g., UL) certification must be corrected at the contractor's expense.

- (e) For Special Systems, provide each outlet minimum 450 mm [18 in.] AFF unless otherwise specified by system design.
- (f) Outlet shall be in separate backbox and not combined with light switches, electrical receptacles, or thermostats.
- (g) Outlets shall not be located within 1200 mm [48 in] of the "swing open" side of inward-opening doors.

2.4 DRAWINGS

- (a) The design professional shall clearly show the locations of TIP, telecommunications outlets, conduit runs, cable trays or wireways, equipment cabinets and/or racks, telecommunications backboards, and pullboxes on the drawings. The drawings shall clearly identify locations of these runs when both originating and terminating points are not shown on the same drawing.
- (b) The design professional shall clearly show the exterior and/or underground TIP raceway system, including distances between buildings, maintenance holes, and in-ground pullboxes.
- (c) All raceways sizes shall be indicated on the drawings.
- (d) Drawings shall include a detailed riser diagram for all distribution systems and the interfaces between systems.

2.5 CONCEALED AND EXPOSED CONDUITS

- (a) Exposed conduit is acceptable where finished ceilings are not provided. Wherever it is impractical to conceal conduits, due to SMCS approved economic considerations or the need to accommodate existing field conditions, the design professional shall consult with VA to determine acceptable alternatives.
- (b) Conduits may be installed in concrete walls and floors.
- (c) Surface metal raceways shall not be installed on the floor. Services to equipment in open non-patient care areas shall be served from under the slab or cabled through tele/power poles from the ceiling.
- (d) Service provider conduits shall not be exposed on the exterior of buildings.
- (e) Refer to Section 27 05 33 RACEWAYS AND BOXES FOR COMMUNICATIONS SYSTEMS for minimum guidelines for conduit, innerducts, boxes, pathways use and TIP locations.

2.6 UNDERGROUND DUCTS AND CONDUITS

- (a) Generally, encase telecommunications underground ducts and conduits in concrete or as described in PSDM.
- (b) Conduits containing telecommunications cabling shall not be exempt from concrete encasement requirements.

CHAPTER 2: RACEWAYS AND PATHWAYS

- (c) Direct burial conduit may be used for outdoor emergency call and intercom cabling.

2.7 INDOOR CONDUITS AND PATHWAYS

Raceways typically required for cabling systems shall be per Table 2-3.

TABLE 2-3 CABLING SYSTEMS PATHWAYS

System	Specification Section	Pathway Requirements
Grounding	27 05 26	Conduit Not Required; but may be used as approved by the RE
Control, Communication and Signal Wiring	27 10 00	Complete Conduit, Allowed in Non-Partitioned Cable Tray or Cable Ladders
Communications Structured Cabling	27 15 00	Conduit to Cable Tray, Partitioned Cable Tray
Emergency Voice Switching System	27 31 00, 27 31 31	Conduit to Cable Tray, Partitioned Cable Tray
Master Antenna Television Equipment and Systems	27 41 31	Conduit to Cable Tray, Partitioned Cable Tray
Public Address System	27 51 16	Complete conduit
Intercommunications and Program Systems	27 51 23	Conduit to Cable Tray, Partitioned Cable Tray; If used as a part of an emergency system complete conduit
Nurse Call	27 52 23	Complete Conduit
Security Emergency Call, Duress Alarm	27 52 31	Conduit to Cable Tray, Partitioned Cable Tray
Miscellaneous Medical Systems	27 52 41	Complete Conduit
Distributed Radio Antenna Equipment and System	27 53 19	Conduit to Cable Tray, Partitioned Cable Tray; in certain areas – Complete Conduit
Grounding and Bonding for Electronic Safety and Security	28 05 26	Conduit Not Required unless required by local code(s)
Physical Access Control System	28 13 00	Conduit to Cable Tray, Partitioned Cable Tray
Physical Access Control System and Database Management	28 13 16	Conduit to Cable Tray, Partitioned Cable Tray
Security Access Detection	28 13 53	Complete Conduit

CHAPTER 2: RACEWAYS AND PATHWAYS

System	Specification Section	Pathway Requirements
Intrusion Detection System	28 16 00	Conduit to Cable Tray, Partitioned Cable Tray
Video Surveillance	28 23 00	Complete Conduit
Electronic Personal Protection System	\	Conduit to Cable Tray, Partitioned Cable Tray; in certain areas – Complete Conduit
Fire Detection and Alarm	28 31 00	Complete Conduit

2.8 SPARE CONDUITS

To accommodate moves, adds and changes, and where capacity is reserved for future use, such as where under-slab or underground conduit is used, the design professional shall provide spare under-slab or underground conduits to an accessible point. The number and size of conduits shall be appropriate to the amount of space served.

2.9 STAIRWELLS

Exit stair enclosures shall not be penetrated by any cables not serving the stairwell. Only cable and conduit serving the stairwell (e.g. card reader, cameras, intercoms, and HVAC equipment necessary for stair pressurization) are permitted. Refer to [CHAPTER 8](#). Delete all caps

2.10 UNDERFLOOR DUCT SYSTEMS

- (a) For new construction of large office areas, provide underfloor telecommunications, and signal systems ducts for the following areas:
 - Personnel Division.
 - Registrar Division.
 - Fiscal Division.
 - Supply Division.
 - Any other large open office spaces where future flexibility is desirable.
- (b) Provide preset service fittings on the underfloor duct for TCOs to suit the furniture layout.
- (c) Space the underfloor ducts 1.5 M [5 ft.] on centers. In structural steel frame buildings, use trench header and utilize the cellular steel as the raceway. Coordinate with the structural engineer to ensure that the proper cells are enclosed for raceway use.
- (d) Treat all under floor space as an “Air Plenum” space; install cables and equipment in accordance with such rating.

2.11 ROOMS REQUIRING UNIQUE CONDUIT ATTENTION

2.11.1 RADIOLOGY ROOMS

- (a) Radiology rooms typically require a manufacturer-specific conduit and wiring trough system. If VA Medical Center has selected a manufacturer,

CHAPTER 2: RACEWAYS AND PATHWAYS

the design professional may base the design on the manufacturer's shop drawings. If the equipment list is not manufacturer-specific, the design professional shall base the design on a typical radiology system.

- (b) The design professional shall provide the following details on the plans for the Radiology Room(s):
 - **Signal Plan:** Design professional shall show complete design for general use communication, and special system outlets. Design professional shall show main and related equipment servicing the radiology equipment. Design professional shall confirm radiology equipment communication requirement with radiology OEM drawings.
 - **Radiology Raceway Layout Plans:** Design professional shall show all surface-mounted and/or recess-mounted raceway systems. Design professional shall show wiring tags for all raceway runs. Design professional shall coordinate existing field conditions, locations, sizes, and quantities of raceways and cables shown on radiology shop drawings with drawings from other trades to avoid conflict in field installation.
 - **Radiology Cabling Schedule:** Design professional shall show a schedule for all cabling tags indicating cable destinations and locations, sizes, types, quantities of all raceways and cables.

2.11.2 TELEPHONE EQUIPMENT ROOM (TER) AND TELEPHONE OPERATOR'S ROOM (IF REQUIRED) (CONTACT OI&T'S TVE [RE PARAGRAPH 1.3] FOR SPECIFIC TECHNICAL ASSISTANCE IN THESE VOICE/PBX ENVIRONMENTS)

- (a) TER / TOR rooms typically require a manufacturer-specific conduit, wiring trough, ladder systems and TIP interfaces. If VA Medical Center has selected a manufacturer, the design professional may base the design on the manufacturer's shop drawings. If the equipment list is not manufacturer-specific, the design professional shall base the design on a typical TER / TOR system (see OI&T DG; plus, [Chapter 8](#) for more specific requirements).
- (b) (WHEN APPROVED) The design professional shall provide the following details on the plans for the TER / TOR Room(s):
 - **Signal Plan:** Design professional shall:
 - i. Show complete design for telephone, OI&T and special system outlets.
 - ii. Show main and related equipment servicing the TER / TOR equipment.
 - iii. Confirm TER / TOR equipment communication requirement with TER / TOR OEM drawings.

CHAPTER 2: RACEWAYS AND PATHWAYS

- **Raceway Layout Plans:** Design professional shall show all surface-mounted and / or recess-mounted raceway systems. Design professional shall show:
 - i. Cable tags for all raceway runs.
 - ii. Design professional shall coordinate existing field conditions, locations, sizes, and quantities of raceways, ladders, conduits and cables shown on TER / TOR shop drawings with drawings from other trades to avoid conflict in field installation.
- **TER / TOR Wiring Schedule:** Design professional shall show a schedule for all cable tags, labels and numbers indicating cabling destinations and locations, sizes, types, quantities of all raceways, ladders, conduits and cables.
- (c) Contact OI&T's TVE (see [Paragraph 1.3](#)) for specific TER / TOR technical and operational requirements.

2.12 POKE-THRU, TELE-POWER POLE

In renovation projects for large open administrative areas, use fire-rated poke-thru devices and/or tele-power poles, as determined by VA.

2.13 ETHYLENE OXIDE STERILIZATION AREA

Determine the extent of the NEC-classified area (if any) in the vicinity of ethylene oxide sterilizers and provide an appropriate raceway system and devices.

2.14 RATED CONSTRUCTION

- (a) Firestop systems at fire and smoke assemblies shall be coordinated so products specified can be reentered during future moves adds and changes without damage to previously installed cables. For cable tray systems, consideration should be given to fire-rated pathway devices however; segregation of cables shall be maintained.
- (b) Determine the extent of rated partitions and non-rated assemblies (i. e. walls, partitions, floors or ceilings) to maintain pressurization of environmental air (e.g. O.R., isolation rooms, negatively pressurized spaces, positively pressurized spaces) or acoustical areas providing sound attenuation or acoustical ceiling located in the path of cabling and specify appropriate re-enterable raceway system seals or acoustical pathway devices at those locations.
- (c) Hardening caulks, sealants and cementitious materials shall not be specified for telecommunications and special systems cabling.

This page intentionally left blank.

CHAPTER 3: TABLE OF CONTENTS

CHAPTER 3:

TABLE OF CONTENTS

3.0	WORK AREA OUTLET AND HORIZONTAL CABLING REQUIREMENTS	3-0
3.1	GENERAL	3-0
3.2	TIP HORIZONTAL MEDIA SELECTION	3-1
3.2.1	BALANCED TWISTED PAIR CABLING	3-1
3.2.2	WIRELESS AND FREQUENCY COORDINATION	3-2
3.3	DISCRETE ANTENNA SYSTEMS	3-3
3.3.1	DISTRIBUTED (IN HOUSE) ANTENNA SYSTEM (DAS)	3-3
3.3.2	WIRELESS MEDICAL TELEMETRY SYSTEM, (WMTS)	3-4
3.3.3	INTRA-BUILDING WIRELESS SYSTEM, WIRELESS LOCAL AREA NETWORK (WLAN)	3-4
3.3.4	FCC & OSHA SAFETY OF LIFE COMPLIANCE AND RESTRICTIONS OF USE	3-7
3.4	CABLE LENGTH	3-8
3.4.1	BALANCED TWISTED PAIR CABLE LENGTH	3-8
3.4.2	OPTICAL FIBER CABLE	3-9
3.4.3	COAXIAL CABLE	3-10
3.5	SPECIFIC APPLICATIONS	3-10
3.5.1	SURGERY ROOMS	3-10
3.5.2	EXTERIOR OUTLETS	3-10
3.5.3	OFFICES AND ADMINISTRATIVE AREAS	3-11
3.5.4	LABORATORIES AND RESEARCH FACILITIES	3-11
3.5.5	MENTAL HEALTH (PSYCHIATRIC) PATIENT ROOMS	3-11
3.6	VIDEO SURVEILLANCE	3-11
3.6.1	TELECOMMUNICATIONS ENCLOSURES	3-11
3.6.2	DIRECT ATTACH MODIFIED PERMANENT LINKS	3-11
3.6.3	SURGE PROTECTION	3-12
3.7	TELECOMMUNICATIONS ROOMS	3-12
3.8	ADAAD REQUIRMENTS (2010 AMERICANS WITH DISABILITIES ACT STANDARDS FOR ACCESSIBLE DESIGN) CHECK TABLE OF CONTENTS NUMBERING AND LINK	3-12
3.8.1	ADAAD PROVIDES THE FOLLOWING INSTALLATION HEIGHT REQUIREMENTS: OPERABLE PARTS SHALL BE PLACED WITHIN ONE OR MORE OF THE REACH RANGES BELOW.	3-12
3.8.2	POOL AREAS	3-15
3.8.3	PUBLIC TELEPHONES	3-15
3.9	BUILDING AUTOMATION SYSTEMS	3-16

CHAPTER 3: TABLE OF CONTENTS

This page intentionally left blank.

CHAPTER 3: WORK AREA OUTLETS AND HORIZONTAL CABLING REQUIREMENTS

3.0 WORK AREA OUTLET AND HORIZONTAL CABLING REQUIREMENTS

3.1 GENERAL

(For additional specific TIP requirements, refer to [Chapter 5](#).)

- (a) The design of the cabling system in existing buildings shall incorporate the existing facility TIP raceway systems. All unused existing distribution wires, cables, and pathway equipment not incorporated in the new or replacement cabling systems ***shall be removed and properly disposed of*** at the direction of the COR.
- (b) Plenum, CMP, rated cable shall be provided in all air-handling plenum locations. Non-plenum, CM or CMR, cable may be provided in all other areas.
- (c) Provide ***separate cable distribution system*** for critical, life, emergency, safety and protection systems (i.e. emergency bypass phones; police emergency voice communications from elevator cars, parking lots, stairwells, personal protection/duress alarms, nurse call/code blue, and PA annunciation systems; etc.). Contact AHJ SMCS 005OP2H3 for specific technical assistance and approvals.
- (d) Voice cables providing emergency voice service to elevator cars shall be extended to a terminal box located outside the elevator shaft, approximately midway between the maximum up/down travel range of the elevator car. The terminal box must be easily accessible from the internal hospital area and connected by 41 mm [1.5 in.] conduit to the nearest TR. Design professional shall coordinate outlet for the elevator car's standard telephone and elevator traveler cable. Telecommunications equipment is not allowed in the elevator machine room and electrical rooms.
- (e) Voice cables providing emergency voice service to parking lot, stairwell, duress alarm ***and other such emergency devices*** shall be extended to a terminal box located inside the facility by 41 mm [1.5 in.] conduit to the nearest TR, The terminal box must be easily accessible from the inside the TR and connected by 41 mm [1.5 in.] conduit to the PCR and EMCR's SCC (and OSP's EMCC if not a part of the EMCR). Design professional shall coordinate outlet for each device's standard telephone and interconnecting cable. Telecommunications equipment is not allowed in the elevator machine rooms and electrical rooms. Provide VSS with "auto-park" function for each device controlled by the SMS in the PCR and EMCR's SCC (and OSP's EMCC if not a part of the EMCR) as approved by SMCS 005OP2H3 on a case-by-case basis.
- (f) The design professional shall refer to the appropriate Design Manual / Guide, where most work area outlet requirements are shown.

**CHAPTER 3: WORK AREA OUTLETS AND HORIZONTAL CABLING
REQUIREMENTS**

- (g) All horizontal TIP wire and cabling shall be installed in a raceway system, which may consist of a mixture of conduits, enclosed cable trays, open wireways, covered cable ducts, Nationally Recognized Testing Laboratory (NRTL)-approved partitioned communications wireways, and/or cable ladders, ***except as specifically disallowed*** by SMCS 005OP2H3 .
- (h) TIP wires or cables may only be installed inside gypsum-board walls using flexible conduit, where specifically approved in writing by the Facility’s OI&T Chief or Chief Engineer and SMCS for each particular location.

3.2 TIP HORIZONTAL MEDIA SELECTION

Design professional must specify horizontal cable based on the project specific needs (See Table 3-1) and according to the information contained herein.

3.2.1 BALANCED TWISTED PAIR CABLING

- (a) Copper conductor balanced twisted pair cable is required in the horizontal TIP (See Table 3-1). Aluminum, copper clad aluminum, or copper clad steel conductors and like wires and cables ***are not permitted***.

TABLE 3-1 Balanced Twisted Pair CENTER HERE

Category	Max. Frequency	Minimum Field Tester Level
Category 3 (included <i>ONLY</i> for Reference)	16 MHz	<i>NOT TO BE USED IN VA PROJECTS</i>
Category 5e	100 MHz	Level IIe
Category 6*	250 MHz	Level III
Category 6A*	500 MHz	Level IIIe

* WLAN may require cable with data rate in excess of 1 Gb/s confirm required cable category and quantity of cables to WAPs with active electronic manufacturer before designing horizontal cable and pathway.

(Note: Category 5e is recommended. Use higher category (6 or 6A) for specialized powered systems technically approved by SMCS 005OP2H3H2, and the Contracting Officer Representative (COR)).

- (b) Jacket color shall be per Table 3-2. Colors for cable jackets refer to horizontal cable not patch cords. OSP cable color shall be black, regardless of category, to accommodate environmental requirements.

**CHAPTER 3: WORK AREA OUTLETS AND HORIZONTAL CABLING
REQUIREMENTS**

TABLE 3-2 Jacket Color

System	Cable Jacket
Voice	White
Data	Yellow
Data	Green
Data	Grey
Wireless	Orange
Video Surveillance	Violet
Nurse Call	Blue
Fire Alarm	Red
BAS & DAS	Black

- (c) When selecting cable, consider PoE effects on the cable installation. Bundling PoE cables can cause an increased temperature inside the bundle and require larger conduit. Derating of cable is required to compensate for heat buildup.
- (d) Shielded cable may be required. F/UTP, shielded or screened cable, has advantages over UTP including improved heat dissipation, higher immunity from EMI in exterior locations, protection from alien crosstalk due to mixing of cables in pathways and spaces.
- (e) Power on balanced twisted pair shall not exceed 60 volts.
- (f) When using consolidation points and MUTOAS derate cable per standards; See [Paragraph 3.4.1.1](#)

3.2.2 WIRELESS AND FREQUENCY COORDINATION

Contact VACO's AHJ for FMS Special Communications, Low Voltage and other Communication Systems, Spectrum Management and COMSEC Service (SMCS 005OP2H3) ***for each*** wireless item and equipment/system for Spectrum and Frequency Coordination.

- (a) Existing Building
Coordinate with VA to obtain results of a series of VA biomed engineering baseline RF measurements using a spectrum analyzer to identify the existing RF environment and areas of potential interference.
- (b) New Construction
Obtain operating frequency band of equipment from the OEM and coordinate with SMCS 005OP2H3 to determine whether the new equipment will cause, or be a victim of, interference.
- (c) Interference Resolution

CHAPTER 3: WORK AREA OUTLETS AND HORIZONTAL CABLING REQUIREMENTS

Refer to [Paragraph 1.8.1.1](#) for DVA Systems for resolution of each noted interference.

3.3 DISCRETE ANTENNA SYSTEMS

3.3.1 DISTRIBUTED (IN HOUSE) ANTENNA SYSTEM (DAS)

Refer to [paragraph 7.2.7.8](#) for additional required information.

An Emergency Radio Communications System installed for Emergency Responder (or first responders and government emergency personnel) ***use only*** while inside the facility to maintain contact with each respective control point.

- (a) **MUST USE** CFM Approved Specification SECTION 27 53 19 - DISTRIBUTED RADIO ANTENNA (WITHIN BUILDING) EQUIPMENT AND SYSTEMS ***in all facilities.***
 - **Must obtain prior approval** from SMCS ***for any*** Service Provider (i.e. AT&T, Verizon, Sprint, etc.) functions to be provided in the facility where each must be compatible with CFM's Approved DAS Specification.
 - SERVICE PROVIDER IN HOUSE WIRELESS SYSTEMS ***ARE NOT PERMITTED*** AND ***WILL NOT BE APPROVED UNLESS EACH GOES THROUGH THE PROJECT PROCESS AND IS APPROVED IN ADVANCE.***
- (b) FCC Part 15 listed wireless systems and equipment ***are not allowed*** for **Safety of Life (i.e., Code Blue, etc.)** functions (Re Paragraph.
- (c) To avoid over design, RF signal survey(s) ***must be done*** for all carriers and on all floors (on high rise buildings over 10 stories, survey upper floors only until residual signal stops increasing). Public safety signal must be the dominant signal and 7dB stronger than any carriers MACRO signals.
- (d) Signal can propagate between floors therefore direct antennas away from multi-story atriums.
- (e) Minimize leakage outdoors. Omnidirectional antennas should not be placed near windows to prevent signal penetration outside the building. New windows, or UV blocking film on older style windows, can prevent signal propagation.
- (f) Include stairwells and elevators. Elevators may not have coverage when doors are closed due to metal doors and shaft. Consider antennas in shaft to donor antenna in elevator car (Other solutions employing fire rated radiating cable or traveler cable may not be available.)
- (g) Provide for zone controller mounting in lockable enclosures to prevent tampering or vandalism
- (h) Design DAS pathways in public areas for Metal Conduit or secure pathway

CHAPTER 3: WORK AREA OUTLETS AND HORIZONTAL CABLING REQUIREMENTS

- (i) DAS Enclosures shall be installed in controlled areas. SMS Control and monitoring is required. If area does not have existing cameras, new video surveillance is required controlled by the SMS in the PCR and EMCR's SCC (and EMCC if not a part of the EMCR).

3.3.2 WIRELESS MEDICAL TELEMETRY SYSTEM, (WMTS)

(Refer to **Paragraphs 1.5.1** and **3.2.2**)

- (a) The WMTS spectrum is used for remote monitoring of patient's health (FCC Part 15 listed wireless systems and equipment is not allowed for Safety of Life Functions).
- (b) There is a WMTS database to assist in ascertaining which frequencies may be used in a given geographic area without fear of interference. The WMTS database records all WMTS equipment, identified by location, operating frequency, emission type and effective radiated power. It has equipment manufacturer and model number for each deployed WMTS device, as well as contact information for each authorized health care provider; contact SMCS 005OP2H3 for spectrum assistance.
 - For WMTS frequency coordination matters, contact: American Hospital Association Director of Engineering and Compliance <http://www.aha.org/>.
- (c) The FCC designated the American Society for Healthcare Engineering of the American Hospital Association (ASHE/AHA) to serve as the exclusive WMTS frequency coordinator. ASHE/AHA's responsibilities include notifying WMTS users and equipment manufacturers of potential frequency conflicts; *HOWEVER*, SMCS 005OP2H3 *must be included* in the overall spectrum management concerning each VA Facility. ASHE/AHA provides access to the WMTS database to authorized parties. ASHE/AHA does not specify the frequencies to be used for any particular WMTS operation nor attempt to resolve any frequency conflicts that may emerge. The FCC's Enforcement Bureau makes the final decision in any frequency disputes that are not resolved by the parties.

3.3.3 INTRA-BUILDING WIRELESS SYSTEM, WIRELESS LOCAL AREA NETWORK (WLAN)

- (a) Contact VA Spectrum Management and COMSEC Service, Special Communications Team (SMCS-005OP2H3) for technical assistance with systems design, preparation and review of construction documents, proof of performance testing and VA certification.
 - FCC Part 15 listed wireless systems and equipment:
 - i. ***Are not allowed for Safety of Life Functions.***
 - ii. ***Must have*** SMCS 005OP2H3 approved MOU **AND** Risk Assessment Forms fully accomplished and signed by all parties

CHAPTER 3: WORK AREA OUTLETS AND HORIZONTAL CABLING REQUIREMENTS

in order to be approved for use (Sample copies are available from SMCS).

- All wireless systems used in VA Facilities *must be compliant* to Paragraphs 1.5.1 and 3.3.2 *and licensed* by VA/NTIA by SMCS 005OP2H3, *or*:
 - i. Have the aforementioned forms completed ***FOR EACH SYSTEM until the OEM working with SMCS*** can obtain an approved government protected RF for their system's use.
 - ii. Sample copies are available from SMCS.
- (b) Intra-building Wireless System, WLAN, requirements include providing Wireless Access Points supporting medical grade wireless equipment operating in the facility at the current time and sufficient coverage, indoor location accuracy and capacity for medical grade wireless equipment that may be added in the future.
- (c) In consultation with the VA, design and install a complete 802.11(*) wireless network solution for the Facility in accordance with VA Wireless Infrastructure Standard and VA Wireless Data Communications Policy to support the Wireless Fidelity (WI-FI) wireless network throughout the Facility. The VA currently utilizes a single wireless network that extends across all the campus. Project shall not install any other 802.11 wireless network in the Facility without prior approval by SMCS 005OP2H3.
- (d) The wireless network in the facility must have sufficient wireless access points to support the medical systems and integration to VA provided systems.
- (e) Refer to SMCS regarding use of the Authority's 802.11(*) wireless network by the RTLS system in the Facility. Design the wireless network to support RTLS throughout the Facility.
- (f) VA responsibilities:

Program and configure wireless access points and redundant wireless controllers furnished and installed by project and provide centralized authentication and security appliances, or latest equivalent, to support the VA's wireless network within the facility. Design professional shall provide assistance as reasonably required.
- (g) Project documents shall:

Install all structured cabling and wireless access points, and test all cable infrastructure and wireless system devices for the wireless network in consultation have VA.
- (h) Provide wireless infrastructure to service 802.11b (2.4Ghz DSSS), 802.11g (2.4Ghz OFDM), 802.11a (5Ghz OFDM), 802.11n Draft 2.0, or newer (5Ghz and 2.4Ghz MIMO), and 802.11ac release 2 wireless communications and data transfer requirements for access by wireless

CHAPTER 3: WORK AREA OUTLETS AND HORIZONTAL CABLING REQUIREMENTS

devices to data and voice services within the facility and across the campus, via the VA WAN.

- (i) Provide a complete structured cabling infrastructure that will allow the installation of the complete wireless network, including PoE wireless access points. Project documents will install telecommunication outlets and access points in consultation with the VA in accordance with VA Wireless Infrastructure Standard.
- (j) Test all aspects of the wireless network and provide heat maps for the Facility indicating the channel coverage, signal level, data rate and noise floor for 802.11 standard including 802.11b, 802.11g, 802.11a and 5GHz 802.11n and 802.11ac wireless networks.
- (k) Include in project documents sufficient cable and install outlets with ability to relocate wireless access points based on a physical site survey after occupation of the Facility.
- (l) The wireless network will provide 100% coverage that meets the performance requirements, as described in VA Wireless Infrastructure Standard, throughout the Facility including elevator cabs, mechanical spaces, service areas, Facility exterior, stairwells, and parking lots.
- (m) Project documents will procure and install Wireless LAN Controllers, licensing, software and Wireless Access Points.
- (n) Performance Criteria:
 - Work with the VA in creating an operational plan for the wireless network complete with management strategy alerts notification and resource requirements for maintenance.
 - **COMPLY WITH VHA's RTLS MOU BEFORE PROCEEDING WITH PLACING THE SYSTEM IN THE PROJECT.** Contact AHJ SMCS ([Re Paragraph 1.3](#)) for a copy of this document.
 - Retain a BICSI RCDD® certified network engineer with expertise and experience working with the VA approved equipment to design the wireless network infrastructure.
 - Ensure each wireless access point will have two Category 5e (Category 6 or Category 6A on a case by case basis for specialized powered systems (e.g., TIA TSB-162-A)) data cables terminated at a telecommunication outlet installed in accordance with VA Wireless Infrastructure Standard.
 - Design the Facility wireless including equipment locations (e.g., MRI, microwave ovens) so that equipment does not interfere beyond the noise floor and signal strength requirements (SNR) of the wireless network. The resulting RF environment in the Facility must be consistent with the strictest specifications of the wireless end-use equipment.

CHAPTER 3: WORK AREA OUTLETS AND HORIZONTAL CABLING REQUIREMENTS

- Provide adequate signal strength and bandwidth within the boundaries of the Facility to support VA systems and RTLS.
- Provide exterior wireless signal strength and bandwidth for outdoor coverage to support the VA's systems in accordance with VA Wireless Infrastructure Standard.

3.3.4 FCC & OSHA SAFETY OF LIFE COMPLIANCE AND RESTRICTIONS OF USE

(Note – extracted from FCC's Rules and Regulations)

- (a)** Federal Communications Commission (FCC) Part 15 Unlicensed Device Compliance: "...devices offered that are listed and/or labeled under the Part 15 Unlicensed Devices portion of FCC's Rules and Regulations, operation is subject to the following conditions, the device:
- May not cause interference,
 - Must accept any interference, including interference that may cause undesired operation of the device. Additionally, an unlicensed device that is FCC Part 15 listed and/or labeled may not be used for safety of life functions or operations, and
 - FCC Part 15 Unlicensed Device Radio Frequency (RF) band(s) are not assigned, owned, managed or otherwise controlled by the Device user; but, by other(s), that is beyond the device user's control....."
- (b)** Typical FCC Part 15 Unlicensed Devices are (but NOT limited to): Wireless Voice over Inter Net Protocol (VoIP), Local Area Wireless Networks (LAN) & Wide Area Networks (WLAN); Cellular Telephones; Wireless Fidelity (Wi-Fi) Equipment; RF Telephones, Sensors, Contactors, Readers and Identification (RFID) Equipment, etc. It is the offerer's responsibility to validate the equipment being offered to insure each does not fall within the restrictive categories identified herein.
- (c)** Contact VA's Spectrum Management and Communications Security (COMMSEC) Service, Special Systems Team (SMCS 005OP2H3) for technical assistance concerning compliance with and/or questions about the information identified herein.
- (d)** If the design professional desires to consider a wireless based item or system, each item or system's operating RF must be VA licensed within the Department of Commerce's National Telecommunications Inter-departmental Agency's (NTIA) Government Protected and Controlled RF Bands.
- (e)** Office of Occupational Safety and Health (OSHA) Nurse Call (Code Blue) Compliance:
- (Note** – extracted from OSHA's Manual of Instructions)

CHAPTER 3: WORK AREA OUTLETS AND HORIZONTAL CABLING REQUIREMENTS

- OSHA requires that if a wireless system is connected to a UL-1069 listed Nurse Call System – BOTH systems be tested to the same UL-1069 standard. ¹
- If a nurse call system interfaces with a pocket paging system, each whole system, the nurse call system plus the pocket paging system, must be tested against the provisions of UL-1069 or its NRTL equivalent. Otherwise the NRTL certification and/or approval, is not valid and it will not meet OSHA requirements.

3.4 CABLE LENGTH

3.4.1 BALANCED TWISTED PAIR CABLE LENGTH

(a) Horizontal Length shall be per Table 3-3.

TABLE 3-3 TWISTED PAIR CABLE LENGTH

Pathway	Minimum Length ^[1]	Maximum Length	Considerations	Notes
TR - TCO	15M* [50 ft.]	90M [295 FT] ^{[2] [3]}	Assumes ambient temperature 20° Celsius [68° F]	Channel distance, which includes Work Area Cords, patch cords/cross connect jumpers and equipment cables shall not exceed 100 M [328 FT]
TR – Consolidation Point	15M* [50 ft.]	85M ^[3] [278 ft.]		
Consolidation Point - TCO	5M [16 FT]			
Work Area Cord	2M [6 ft.]	5M [16 FT]		
Patch Cord	2M [6 ft.]			No cross connect ≤ 1M [3 ft.]
Equipment Cord ^[4]	2M [6 ft.]	5M [16 FT]		

^[1] Electrical length of the shortest pair = Nominal Velocity of Propagation, NVP, x speed of light, C, x Propagation Delay

^[2] Data Center Hot Aisle up to 40°C [104°F] derate length 6M [20 ft.]

^[3] Ceiling up to 60°C [140°F] derate length 15M [50 ft.]

^[4] Use small diameter patch cords (e.g., 28 Gauge engineered short length less than 30M [100 ft.]) only at 20°C [68°F].

**CHAPTER 3: WORK AREA OUTLETS AND HORIZONTAL CABLING
REQUIREMENTS**

- (b) SMALL DIAMETER PATCH CORDS SHALL NOT BE USED OUTSIDE OF COOLED CABINETS.

3.4.1.1 MULTI-USER TELECOMMUNICATIONS OUTLET ASSEMBLY (MUTOA)

- (a) On a case by case basis, MUTOA cabling design may allow work area equipment cords to extend beyond 5 M [16.5 ft.], depending upon the length of the horizontal cable.
- (b) The total channel length must be reduced by shortening the horizontal cable due to the fact stranded conductor cables have greater attenuation than solid conductor cables. For technical assistance, contact VA's Spectrum Management and COMSEC Service (SMCS-005OP2H3).
- (c) For 24 AWG {0.51 mm [0.020 in]} cable only, calculate shortened link length using the maximum allowable cable lengths with the use of the MUTOA table in TIA-568C. For all other cables, calculate shortened link length using formulas taking into account requirements for maximum allowable length of TR equipment cords and patch cords.
- (d) Do not use 24 AWG {0.51 mm [0.020 in]} work area equipment cords with lengths that exceed 22 m [72 ft.].
- (e) Require any MUTOA be marked with the maximum allowable work area equipment cable length.

3.4.2 OPTICAL FIBER CABLE

- (a) Cable Length shall be per Table 3-4.

TABLE 3-4 OPTICAL FIBER LENGTH

Distance	OM1	OM4	OS1	OS2*	Data Rate
FIBER	62.5/125 µm	50/125 µm	9/125 µm	9/125 µm	
62.5/125 (for Bell System Compatibility)	2000M [6562 FT]				155 Mb/s
Facility / Campus Backbone		550M [1804 FT]			10 Gb/s
Facility / Campus Backbone		150M [492 FT]	2000M [6562 FT]	10000 M [32,808 FT]	100 Gb/s

*OS2 on a case by case basis ***obtain prior approval*** by SMCS and COR (For technical assistance contact VA's Spectrum Management and COMSEC Service (SMCS-005OP2H3)).

CHAPTER 3: WORK AREA OUTLETS AND HORIZONTAL CABLING REQUIREMENTS

3.4.3 COAXIAL CABLE

Coaxial cable is a cost effective MATV and other baseband distribution solution. Attenuation is the key factor in selecting a coaxial cable. Coaxial cable shall not be chosen by only identifying the series or size. Attenuation depends on the signal amplification, the length of cable, the cable size, and the dielectric material and number of connections.

(a) Branch

Use Series-6, Series-11, or appropriate hardline, minimum 13 mm [1/2 inch] coaxial cable, to achieve the specified signal level at TCOs. Series-11 coaxial cable or 13 mm [1/2 inch] hardline coaxial cable is preferred in broadband branch (horizontal) runs exceeding 45.72 m [150 feet].

(b) Trunk

Show on the drawings a minimum of two coaxial cables between the head end and each riser patch panel to comprise an individual circuit. Trunk (backbone) cable shall be designed with 13 mm [1/2 inch], semi-rigid coax, riser rated type minimum. Increase size (e.g. 19 mm [3/4 inch]) to meet system design signal level.

3.5 SPECIFIC APPLICATIONS

3.5.1 SURGERY ROOMS

- (a)** Refer to Surgical Service Design Guide.
- (b)** Wall-mounted outlets shall be 450 mm [18 in.] above the floor.
- (c)** The need for special outlets for portable equipment shall be determined on a project-by-project basis.
- (d)** Design operating room cable jackets for non-flammable anesthetics only.
- (e)** Provide non explosion proof, locking outlets at ceiling locations and at wall locations.
- (f)** Do not place next to FMS, OI&T or patient care rooms or like areas.
- (g)** Do not route room / equipment piping through FMS, OI&T, patient care or like areas.
- (h)** Insure all TIP, FMS and OI&T equipment are able to be sanitized according to the Surgical Service Guide.

3.5.2 EXTERIOR OUTLETS

Provide exterior weatherproof TCO mounted in NEMA 3R weatherproof enclosures at the following locations:

- (a)** FMS Emergency voice outlet helicopter operational area(s); each home run to emergency room nurses station operator's console, with secondary connection(s) to the SMS in the PCR and EMCR's SCC (and OSP's EMCC if not a part of the EMCR).

CHAPTER 3: WORK AREA OUTLETS AND HORIZONTAL CABLING REQUIREMENTS

- (b) FMS Emergency intercom outlet at hospital premise entrances and exits home run to the SMS in the PCR and EMCR's SCC (and OSP's EMCC if not a part of the EMCR).
- (c) FMS Emergency voice outlet in parking lot, decks and stairwells home run to the SMS in the PCR and EMCR's SCC (and OSP's EMCC if not a part of the EMCR, and may be included as a part of the Emergency Voice Communications System).
- (d) OI&T voice outlet at courtyards and enclosed (or partially enclosed) garden areas to the telephone PBX (if used), or VoIP system in the OI&T MCR.
- (e) OI&T voice outlet on loading docks to the telephone PBX (if used), VoIP system in the OI&T MCR.

3.5.3 OFFICES AND ADMINISTRATIVE AREAS

- (a) Small Rooms: Provide at least one (1) TCO *on each wall* for voice and data uses If TCOs *are not* shown *or* referenced on the project drawings.
- (b) Open Spaces and Large Rooms: Install telecommunications outlets for large open administrative rooms in underfloor raceways or in Tele/Power Poles. Refer to [SECTION 2.10 UNDERFLOOR DUCT SYSTEMS](#).

3.5.4 LABORATORIES AND RESEARCH FACILITIES

Refer to Research Laboratory Design Guide.

3.5.5 MENTAL HEALTH (PSYCHIATRIC) PATIENT ROOMS

(See [paragraph 9.3](#) for specific information hot link this)

3.6 VIDEO SURVEILLANCE

3.6.1 TELECOMMUNICATIONS ENCLOSURES

Telecommunications Enclosures (TEs) are small wall mounted lockable cabinets that contain backbone and horizontal cabling cross connections. On a case by case basis, TEs may be permitted during design process only where specifically approved by SMCS and COR to serve environments like entrance lobbies, or historic buildings where the construction of a TR is not allowable. TEs shall be installed on the same floor as the TCO termination. A TE is intended to serve a specific area in addition to the TR on the floor. TE also provides a controlled environment to house telecommunications equipment, connecting hardware, and splice closures serving a portion of the building.

3.6.2 DIRECT ATTACH MODIFIED PERMANENT LINKS

Direct attach permits horizontal cabling to be terminated with a field installable plug and then connected directly to IP cameras, or other security equipment avoiding a point of failure. Direct Attach Plugs decrease locations connecting IP security equipment, to the local area network using a patch cord from the TCO. Many cameras are located in the ceiling and most patch cords are not constructed

CHAPTER 3: WORK AREA OUTLETS AND HORIZONTAL CABLING REQUIREMENTS

with plenum-rated cable. Using a non-plenum cable in a plenum space is in violation of codes.

3.6.3 SURGE PROTECTION

- (a) Provide for data circuit protection modules that provide protection against overvoltage and overcurrent conditions at all cables that enter the facility from the exterior including equipment attached to the exterior wall of the building (e.g., IP security cameras). Approve only devices rated for PoE at equipment using PoE.
- (b) Locate surge protection devices at the closest location to the point of entrance that is concealed and accessible while preserving the shortest distance between the protector and bonding conductor.
- (c) Shielded balanced twisted pair cable:
Shielded balanced twisted pair cable (i.e., S/UTP, F/UTP, ScTP, STP, and FTP) should be specified in demanding electrical environments. Environments include locations where installation is required near large inductive loads in close vicinity to the camera or cable. Take into consideration, some IP camera manufactures require shielded cable to maintain the warranty where the camera is installed outdoors or where the network cable is routed outdoors.

3.7 TELECOMMUNICATIONS ROOMS

Refer to [Chapter 8](#)

3.8 ADAAD REQUIREMENTS (2010 AMERICANS WITH DISABILITIES ACT STANDARDS FOR ACCESSIBLE DESIGN) CHECK TABLE OF CONTENTS NUMBERING AND LINK

3.8.1 ADAAD PROVIDES THE FOLLOWING INSTALLATION HEIGHT REQUIREMENTS: OPERABLE PARTS SHALL BE PLACED WITHIN ONE OR MORE OF THE REACH RANGES BELOW.

- (a) **Forward Reach Unobstructed:** Where forward reach is unobstructed, high forward reach shall be 1220 mm [48 inches] maximum and the low forward reach shall be 380 mm [15 inches] minimum A.F.F.

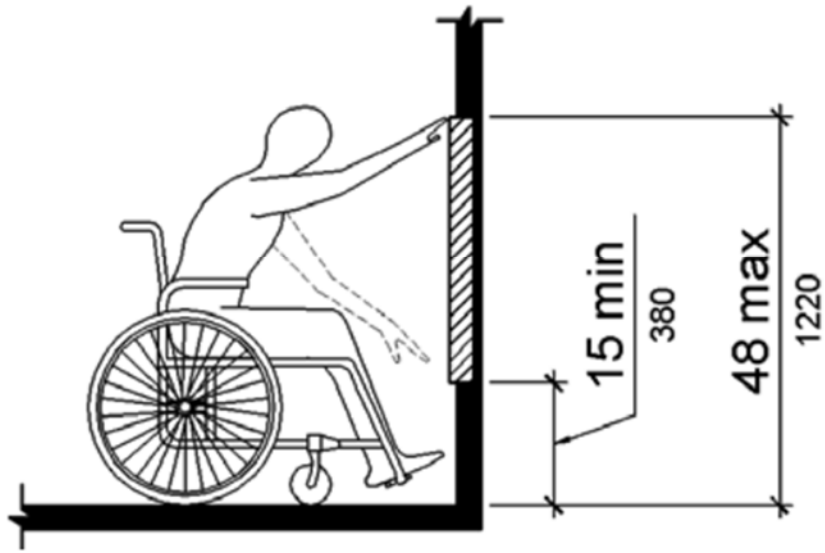

Figure 1: This image depicts a person reaching up from a wheelchair and reaching down.

- (b) Obstructed High Reach: Where high forward reach is over an obstruction, and the reach depth exceeds 510 mm [20 inches], the high forward reach shall be 1,120 mm [44 inches] maximum and the reach depth shall be 635 mm [25 inches] maximum.

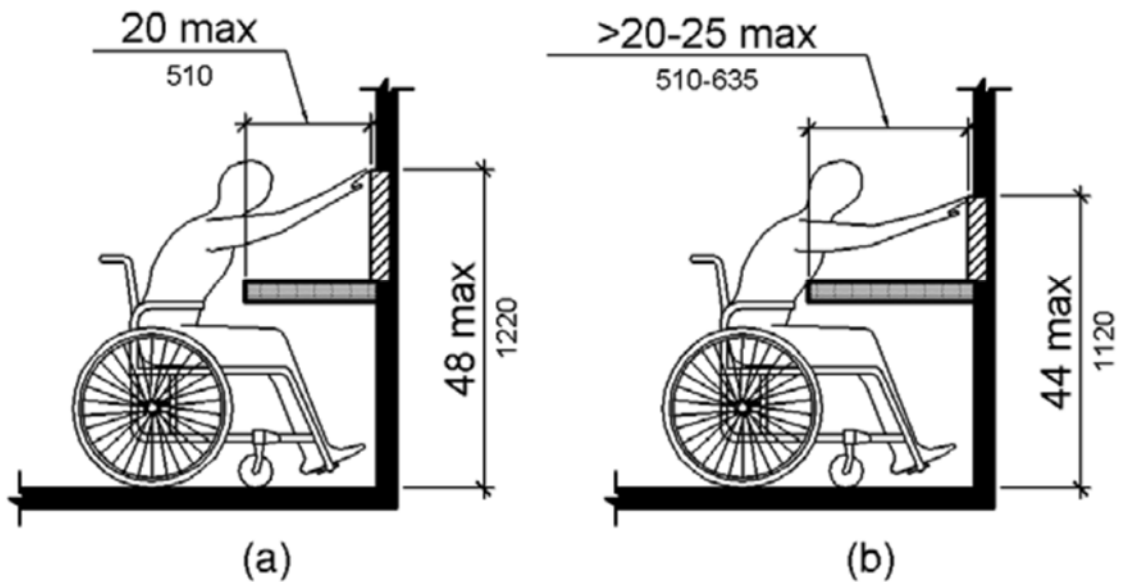

Figure 2 This image depicts a person reaching up from a wheelchair over an obstruction.

CHAPTER 3: WORK AREA OUTLETS AND HORIZONTAL CABLING REQUIREMENTS

- (c) **Side Reach Unobstructed:** Where side reach is unobstructed, the high side reach shall be 1220 mm [48 inches] maximum and the low side reach shall be 380 mm [15 inches] minimum A.F.F.

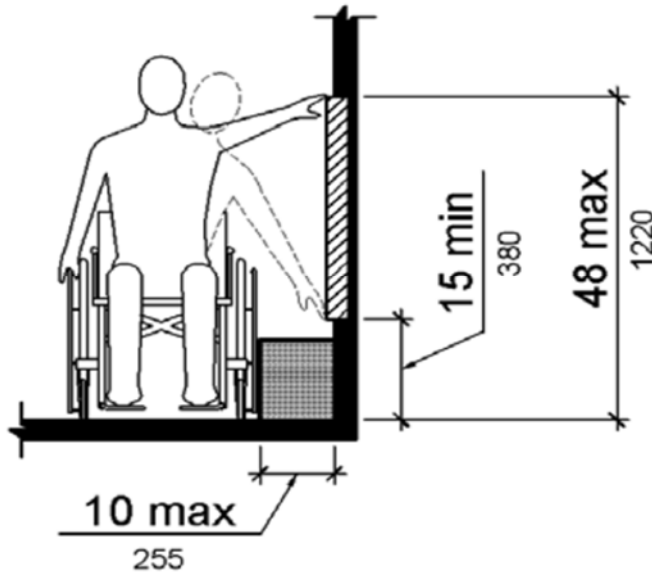

Figure 3: This image depicts a person reaching up to the side from a wheelchair and reaching down to the side.

- (d) **Obstructed High Reach:** Where the high side reach is over an obstruction, the high side reach shall be 1,220 mm [48 inches] maximum for a reach depth of 255 mm [10 inches] maximum. Where the reach depth exceeds 255 mm [10 inches], the high side reach shall be [1170 mm] 46 inches maximum for a reach depth of 610 mm [24 inches] maximum.

CHAPTER 3: WORK AREA OUTLETS AND HORIZONTAL CABLING REQUIREMENTS

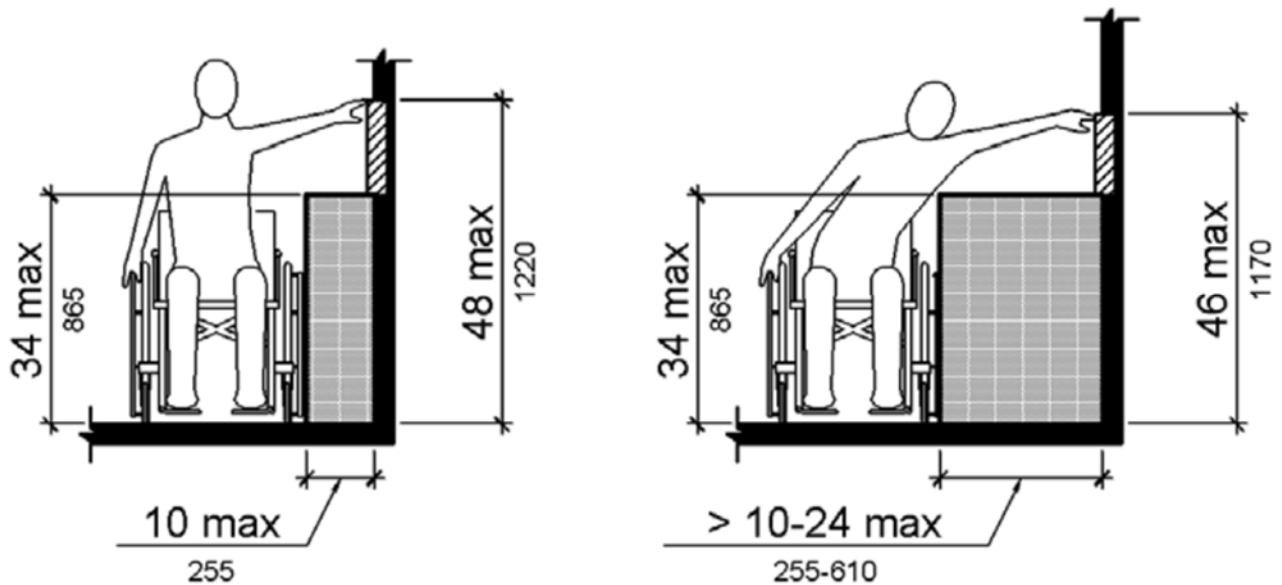

Figure 4 This image depicts a person reaching up and to the side over obstructions from a wheelchair.

3.8.2 POOL AREAS

- (a) Swimming pool areas (includes whirlpool, hot tub, or spa) shall have an ADA compliant communication system that in the event of an emergency, can summon assistance with the push of a button using analog phone lines (PBX or Emergency Voice Switching System).
- (b) The Emergency Phone device shall have a single push button pressed once to call security, and then provide hands-free two-way voice communication.
- (c) Emergency Phone shall be constructed to provide protection with respect to harmful effects on the equipment due to the ingress of water (splashing water, and hose directed water); and provide protection against corrosion from chlorine.

3.8.3 PUBLIC TELEPHONES

- (a) Where coin-operated public pay telephones, coinless public pay telephones, public closed-circuit telephones, public courtesy phones, or other types of public telephones are provided, ADAAD compliant analog accessible telephones shall be provided.

CHAPTER 3: WORK AREA OUTLETS AND HORIZONTAL CABLING REQUIREMENTS

- (b) All Public Safety Answering Points (PSAPs) including where at least one public pay telephone is provided serving the emergency room, recovery room, or hospital waiting room, at least one ADAAD compliant analog public phone to provide direct, equal access to their services for people with disabilities who use wheelchairs or teletypewriters (TTYs), which are also known as telecommunications devices for the deaf (TDDs), shall be provided at each location.

3.9 BUILDING AUTOMATION SYSTEMS

When requested by the building support systems planner, provide TCO at identified locations to support building automation systems. For example, one such outlet may be a direct digital controller (DDC) outlet for the HVAC system. The telecommunications designer does not have primary responsibility for identifying these TCO locations, and should defer to the building support systems planner.

1

Office of Occupational Safety and Health (OSHA) Nurse Call Compliance [re Department of Labor, Assistant Secretary for OSHA, Washington, DC 20210, decision of ‘Adding RF Type Systems to Nurses Call Systems’] “As far as the Nurses Call Issue – OSHA requires that if a wireless system is connected to a NRTL (UL-1069) listed Nurse Call System – BOTH systems will have to be tested to the same UL-1069 standard”. Here is the EXTRACT we provide to our customers:

- NOTE - Office of Occupational Safety and Health (OSHA) Nurse Call Compliance (re Department of Labor, Assistant Secretary for OSHA, Washington, DC 20210, Letter dated 08/1989 – OSHA’s Decision of ‘Adding Systems to Nurses Call Systems’) “...If a nurse call system interfaces with a pocket paging system, each whole system (the nurse call system plus the pocket paging system) must be tested against the provisions of NRTL (UL-1069) or its NRTL equivalent. Otherwise the NRTL certification and/or approval, is not valid and it will not meet OSHA requirements...”

The above was expanded and updated September 12, 1991 for ‘interface & add on’ items, by OSHA’s response to:

Mr. Kenneth T. James
Chairman, Hospital Signaling Group
National Electrical Manufacturers Association
(NEMA)
Suite 300
2101 L Street, N.W.
Washington, D.C. 20210

Specifically, Par.4.2 of UL 1069 states:

“isolation shall be provided between any equipment, such as CRTs, printers, pocket page, telephone and the like, and circuits extending into the patient care area stations so that, in the event of breakdown between primary and secondary windings, the high voltage does not appear on the patient circuits and the sum of

CHAPTER 3: WORK AREA OUTLETS AND HORIZONTAL CABLING REQUIREMENTS

the leakage currents from the nurse call system and ancillary equipment does not exceed the limits of the Leakage Current Test as described in this Standard.....”

(4)“In light of the above communication, interface units determined by Underwriters Laboratories to be in compliance with the new UL 1069 requirements which will go into effect on March 1, 1992, will be acceptable under OHHA’s 29 CFR 1910.303(a). Pocket page transmitters and other ancillary equipment connected to acceptable interface units must also have been determined to be safe, independently or in combination with the interface unit, by a nationally recognized testing laboratory.”

CHAPTER 4: TABLE OF CONTENTS

CHAPTER 4: TABLE OF CONTENTS

4.0	GENERAL	4-1
4.1	INTERIOR CIRCULATING GROUNDING SYSTEM	4-1
4.1.1	INTERNAL TELECOMMUNICATIONS MAIN GROUNDING BUSBAR (TMGB)	4-1
4.1.2	TELECOMMUNICATIONS BONDING BACKBONE	4-2
4.1.3	TELECOMMUNICATIONS GROUND BUSBAR TGB.....	4-2
4.1.4	SUPPLEMENTAL BONDING GRID (SBG (A.K.A. UNDERFLOOR GROUNDING GRIDS))	4-2
4.1.5	BONDING WITHIN RACKS AND CABINETS	4-3
4.2	EXTERNAL COMMUNICATIONS GROUNDING SYSTEM	4-4
4.2.1	GROUNDING	4-4
4.2.2	FACILITY LIGHTNING PROTECTION SYSTEM	4-4
4.2.3	APPROVED BONDING METHODS.....	4-4
4.2.4	EXOTHERMIC WELDING:	4-4
4.2.5	IRREVERSIBLE HIGH COMPRESSION FITTINGS.....	4-4
4.2.6	EXTERNAL COMMUNICATIONS MAIN LIGHTING GROUNDING BUSBAR (CMLGB)	4-5
4.2.7	COMMUNICATIONS CLPS COMPONENTS.....	4-5
4.2.8	CORROSION PROTECTION.....	4-6
4.3	ANTENNA FARM COMPONENTS – SHALL BE CONNECTED TO THE EXTERNAL CLPS:	4-6
4.3.1	IF A FACILITY EXTERNAL LPGS DOES OR WILL NOT EXIST	4-7

CHAPTER 4: TABLE OF CONTENTS

This page intentionally left blank.

CHAPTER 4: COMMUNICATIONS GROUNDING SYSTEM

4.0 GENERAL

The design professional should be familiar with Motorola Inc., Standards and Guidelines for Communications Sites, Manual R-56, Chapters 4 – External Grounding and 5 – Internal Grounding (Reference use by permission).

4.1 INTERIOR CIRCULATING GROUNDING SYSTEM

(See [Paragraph 7.3.4](#) CCGS for additional requirements)

The internal Communications Circulating Grounding System (CCGS) shall be shown complete on a one-line diagram with all components and descriptions from the Intersystem Bonding Termination (IBT), the service equipment to the TGBs, as applicable for each project. The CCGS shall be on the one-line diagram for the communications systems and shall be shown complete, including but not limited to cabinets, racks, cable tray, etc. ([Paragraph 7.3.4](#)).

- (a) Refer to [APPENDIX A](#), DRAWINGS for more information on possible system topologies one-line diagram.
- (b) Refer to Specification Section 27 05 26 – GROUNDING AND BONDING FOR COMMUNICATIONS SYSTEMS, must be used.

4.1.1 INTERNAL TELECOMMUNICATIONS MAIN GROUNDING BUSBAR (TMGB)

- (a) Locate TMGB in the facility utility entrance, as close as practical to the primary or secondary protectors and near the electrical panel to which it will be bonded.
- (b) TMGB shall be sized according to the anticipated number of bonded connections. It shall be a minimum of 1/0 AWG Stranded Copper Wire.
- (c) Building steel within 1.8 m [6 feet] of the communications grounding system should be bonded into the system.

4.1.1.1 INTERSYSTEM BONDING (CHANGE TO FONT ARIAL FONT 12) AND REPARAGRAPH

- (a) The NEC Section 250.94 Intersystem Bonding Termination (IBT) should use the accessible grounding electrode conductor as the preferred telecommunication system bonding point. Coordinate the IBT design with the Electrical Engineer for connection of the CCGS. The IBT cannot be installed inside of an electrical enclosure, especially one that would be off-limits to FMS technology workers. The IBT cannot be hidden or located in a place not readily accessible to systems installers.
- (b) An IBT telecommunication system bonding point shall be required at any additional building on the campus served by feeders from the primary building or structure, and should be located as close as practicable to the disconnecting means of the additional building or structures.
- (c) Bonding Conductor for Telecommunications (BCT), connecting the TMGB to the IBT, shall be sized at least one (1) size larger than TBB. Where practical, BCT length should be less than 9 m [30 feet].

CHAPTER 4: COMMUNICATIONS GROUNDING SYSTEM

4.1.2 TELECOMMUNICATIONS BONDING BACKBONE

- (a) TBB conductor size shall comply with TIA 607-B recommendations based upon total TBB length.
- (b) Provide a minimum #1/0 AWG, Stranded Copper Wire and avoid splicing.
- (c) TBB in multi-story buildings with multiple risers (multiple TBBs) shall employ a grounding equalizer (GE) between vertical grounding backbones at the top floor of the building and minimally at every third floor in between to the lowest floor level. The GE shall be no smaller than the largest sized TBB.
- (d) Bonding conductors should be continuous and routed in the shortest possible straight line path, avoiding changes in elevation and sharp bends.
- (e) TBB conductors shall be protected from mechanical damage.
- (f) Routing grounding conductors through ferrous metal conduit should be avoided, where necessary due to building constraints, grounding conductors installed in ferrous raceway longer than 1 m [3 feet] shall be bonded at the end. Conductors used to bond TBB to conduit ends shall be of #6 AWG or larger.
- (g) Connections (bonds) between the CCGS grounding network and associated electrical panels shall be done ONLY in accordance with the NEC.

4.1.3 TELECOMMUNICATIONS GROUND BUSBAR TGB

- (a) Each TR shall have its own TGB to which equipment, building steel and support structures in that room are bonded.
- (b) The TGBs shall be sized according to the anticipated number of bonded connections.
- (c) Building steel within 2 m [6 feet] of the TGB should be bonded into the system.
- (d) Rack Bonding Conductors (RBC) shall be a minimum #6 AWG Stranded Copper Wire, installed to maintain a minimum of 7.62cm [2 inches] separation from all other types of cable - power or communications. To maintain this segregation of cables some routing of bonding conductors may be outside of, yet parallel to ladder rack or basket tray.
- (e) Bonding conductor support systems shall be spaced no further apart than 2m three (3) foot intervals.

4.1.4 SUPPLEMENTAL BONDING GRID (SBG (A.K.A. UNDERFLOOR GROUNDING GRIDS))

- (a) OI&T Equipment Rooms and Data Centers shall include underfloor supplemental bonding grids (SBG).
- (b) Flooring system must be made electrically continuous, with the grid bonded a minimum of every fifth (5th) pedestal in each direction as per

CHAPTER 4: COMMUNICATIONS GROUNDING SYSTEM

TIA 607-B Standard, using a size #4 AWG or larger Stranded Copper conductor and the pedestal clamps. Individual projects requiring larger conductor sizes or greater clamp density shall take precedent over these guidelines.

- (c) Underfloor SBG shall bond to the TMGB or TGB in the equipment room and MCR with a conductor of 1/0 AWG Stranded Copper Conductor or larger.
- (d) Racks and cabinets shall bond to the SBG with a conductor size of #6 AWG or larger.
- (e) Each rack or cabinet will have individual bonding conductors into the grounding grid. Serial connections (or "daisy-chaining") between communications bays is strictly forbidden and will not be accepted.
- (f) Power Distribution Units (PDU) shall bond into the Mesh-BN per requirements of NEC 250.122 and per OEMs' recommendations.
- (g) Heating, ventilating and air-conditioning (HVAC) shall have bonding conductors into the underfloor grid of #4 AWG Stranded Copper Conductor or larger.
- (h) Each steel column in the communications room shall bond into the Mesh-BN with a conductor of size #4 AWG Stranded Copper Conductor or larger.
- (i) All metal cable trays or ladder rack shall be bonded into the grid with a conductor size of #4 AWG Stranded Copper Conductor or larger. These may be bonded in series.
- (j) All metallic conduits, water pipes and air ducts shall be bonded to the grid with a conductor size of #6 AWG Stranded Copper Conductor or larger. These may be bonded in series.

4.1.5 BONDING WITHIN RACKS AND CABINETS

- (a) Depending on size of the TR, Rack Bonding Conductors (RBC) should tap into underfloor or overhead grounding conductors. Smaller TR should bond directly from the rack / cabinet to the TGB.
- (b) Racks and cabinets shall have grounding busbars installed along one rail to provide effective bonding of rack / cabinet mounted equipment.
- (c) Larger equipment (chassis switches) with integral grounding terminals shall be bonded to the vertical busbar with equipment grounding conductor attached to those terminals and bonded to the rack-mounted busbars.
- (d) Smaller equipment (servers, switches) not having integral grounding shall be bonded from the rack grounding busbar:
 - To a grounding lug connected to an accessible equipment chassis metal screw (insure the chassis paint is removed where the lug connects to

CHAPTER 4: COMMUNICATIONS GROUNDING SYSTEM

insure a good connection). Connect the lug to the rack grounding buss with a minimum #10AWG Stranded Copper Conductor,

- OR (if approved by SMCS) Through the equipment mounting flanges using thread-forming grounding screws with serrations under the head to cut through any paint, coatings and oxidation on the equipment flange.

4.2 EXTERNAL COMMUNICATIONS GROUNDING SYSTEM

4.2.1 GROUNDING

- (a) The external Communications Lightning Protection System (CLPS) (Re [Paragraph 7.2.8](#) shall be shown complete on a one-line diagram with all components and descriptions from the External Ground Bonding Termination (EGBT) at the connection point with the Facility Lightning Protection System (FLPS) to the External Grounding Busbar (EGB) outside the Antenna HE Room, and the interconnection of all Communication Antenna Farm Equipment, as applicable for each project. The CLPS one-line diagram shall include, but not be limited to: EGBT, EGB, earth grounding conductor (EGC), antenna discharge units (ADU), RF Transmission Line (coaxial) cables bonding, antenna masts (towers if used), mounts, junction points, vertical and horizontal grounding conductors, bonding, shielding, etc.
- (b) Refer to [APPENDIX A, DRAWINGS](#) for more information on possible system topologies one-line diagram.

4.2.2 FACILITY LIGHTNING PROTECTION SYSTEM

- (a) Refer to Specification SECTION 26 41 00 – FACILITY LIGHTNING PROTECTION as the base technical requirement.
- (b) Insure the system conforms to NFPA 780 Standard for the Installation of Lightning Protection Systems.

4.2.3 APPROVED BONDING METHODS

4.2.4 EXOTHERMIC WELDING:

- (a) Is a procedure of welding electrical components without an external heat source (i.e. LP gas or arc),
- (b) Use OEM approved safety clothes and procedures, and
- (c) Shall be performed by an OEM certified welding technician.

4.2.5 IRREVERSIBLE HIGH COMPRESSION FITTINGS

- (a) Is a procedure where two (2) components are joined by an approved high compression connector as approved by the OEM,
- (b) Only use OEM approved compression tools sized for the job,
- (c) Use OEM approved safety clothes and procedures,
- (d) Use connectors of same material as the items being bonded together, and

CHAPTER 4: COMMUNICATIONS GROUNDING SYSTEM

- (e) Shall be performed by an OEM certified bonding technician.

4.2.6 EXTERNAL COMMUNICATIONS MAIN LIGHTING GROUNDING BUSBAR (CMLGB)

- (a) Located in the Antenna HE Room exterior wall at the RF transmission line(s) building point of entry (aka thru wall feed thru).
- (b) Ensure the CMLPS is directly connected to the facility's external FLPS at a location approved by the FLPS Contractor and Facility Engineer. The design professional shall assist the Communications System Contractor in contacts with the FLPS Contractor. Obtain FLPS Contractor written approval for the connection of the Communications CLPS to the FLPS and make that authorization a part of the system's final approved installation drawings and specifications.
- (c) If the Facility location:
- **Does not** have an external FLPS, the design professional shall contact the Project Manager and SMCS 005OP2H3 so corrective action can be provided.
 - **Does not or will not** have a FLPS the CLPS can connect; the design professional shall extend the CLPS system design to connect to an approved and certified external earth ground.
- (d) The design professional shall maintain close contact with SMCS 005OP2H3 for technical assistance in developing a complete Communications CLPS that is connected directly from the EGB to a qualified and certified earth ground.

4.2.7 COMMUNICATIONS CLPS COMPONENTS

- (a) Installed with an external Facility FLPS:
- The EGB shall be a copper bus plate minimum 150 mm x 450 mm x 13 mm [6 in x 18 in x 0.5 in]
 - Installed at the Antenna HE Room exterior wall RF Cables Point of Entry [aka weather-proof wall feed-thru],
 - Internal CLGB shall be a copper bus plate minimum 150mm x 450mm x 13mm [6 in x 18 in x 0.5 in],
 - The Internal CLGB shall be directly connected to the EGB with a minimum of two (2) #4/0 AWG copper stranded wire. Each connection shall be a minimum Exothermic Weld, OR approved Irreversible Compression connector,
 - DO NOT connect the CLGB to **or** use the Antenna HE Room's Internal CCGS MGB for this function,
- (b) Connect each ADU to the Internal CLGB (Note: DO NOT interconnect the Antenna HE Room's Internal MGB to the Internal CLGB,
- Each internal CLGB connection (other than ADU connections) shall be listed lugs, pressure connector, clamp or other connection specifically approved by SMCS 005OP2H3,

CHAPTER 4: COMMUNICATIONS GROUNDING SYSTEM

- ***DO NOT*** connect Antenna HE Room internal equipment to the internal CLGB, and
 - ***ALL CONNECTING HARDWARE*** shall be listed for the cable, size and purpose which it is used.
- (c) Antenna Farm Interconnecting Ground Wires:
- Shall be a minimum #1/0 AWG Stranded Copper Horizontal Ground Bonding Conductor (HGBC). The design professional shall ensure the trunk is sized properly to handle existing and planned Antenna Farm components,
 - Each Antenna Farm Component shall be connected to the HGBC with a Vertical Ground Bonding Conductor (VGBC) that is a minimum #1/0 AWG Stranded Copper Conductor, and
 - Each External LPGS HGBC and VGBC Ground Bonding connection point shall be at a minimum Exothermic Welded Joint.
- (d) Each Antenna Farm Equipment shall be bonded to the External CLPS as required by the OEM *OR* as approved by SMCS 005OP2H3.
- (e) Bonding conductor support systems shall be spaced no further apart than 0.61 m [2 foot] intervals and be provided with protective enclosure.

4.2.8 CORROSION PROTECTION

- (a) Provide external corrosion control as described herein and appropriate CFM Specifications,
- (b) Additional Corrosion Control
- Use the Cathodic Protection method.
 - Comply with TIA 222-G.
 - Use only under the direction of a licensed professional engineer.

4.3 ANTENNA FARM COMPONENTS – SHALL BE CONNECTED TO THE EXTERNAL CLPS:

- (a) Antenna Pre-amplifier – shall be bonded to the Antenna Mast (or Tower):
- By minimum #4 AWG Stranded Copper Conductor.
 - The wire shall be connected to the mounting structure as approved by the OEM.
- (b) RF Transmission Line (aka RF Coax Cable) – shall be bonded to the:
- First point of the antenna support, as near the antenna as practical, by an ANSI T1 334 compliant junction.
 - Second point of the Antenna Support, near the bottom of the mounting assembly, by an ANSI T1 313 compliant junction.
 - The outside point at the Antenna HE Room External LPGSB by an ANSI T1 334 compliant junction.
 - The inside point of the Antenna HE Room internal LPGB by an ADU for each RF Transmission (aka Coax) line.

CHAPTER 4: COMMUNICATIONS GROUNDING SYSTEM

- (c) Roof / Wall Mounted Antenna Mast and Support Structures Each item shall be grounded in accordance with NEC, Article 810.15.
- (d) When a Facility External FLPS is present, connect the External CLPS HGBC conductor to the Facility External FLPS via an IEC 61024-1-2, NFPA 780 compliant junction point.

4.3.1 IF A FACILITY EXTERNAL LPGS DOES OR WILL NOT EXIST

- (a) Provide an External CLGS identified here-in; and extend a new External CLPS to the nearest verified and certified earth ground.
 - Via a VGBC minimum 4/0 AWG Stranded Copper Conductor from the Antenna Farm External LPGS connection point to the earth ground in an approved protective jacket / conduit,
 - Support / anchor the protective jacket / conduit per VA specifications and Facility Engineer instructions.
 - Ground Rods shall be NRTL (UL 467) listed, Solid Copper, Copper-clad Steel, Hot-dipped Galvanized Steel or Stainless Steel, and Comply with ANSI-J-STD 607 and T1.334, NEC as appropriate.

CHAPTER 4: COMMUNICATIONS GROUNDING SYSTEM

This page intentionally left blank.

CHAPTER 5: TABLE OF CONTENTS

CHAPTER 5:

TABLE OF CONTENTS

5.0	TELECOMMUNICATIONS INFRASTRUCTURE PLANT (TIP).....	5-3
5.1	TIP REQUIREMENTS.....	5-3
5.2	BACKBONE DISTRIBUTION	5-3
5.2.1	GENERAL	5-3
5.2.2	ROUTE DIVERSITY	5-4
5.3	OUTSIDE PLANT CABLING.....	5-4
5.3.1	BACKBONE TOPOLOGIES.....	5-4
5.3.2	CABLING TYPES	5-5
5.4	OPTICAL FIBER CONSIDERATIONS.....	5-6
5.4.1	CENTRALIZED OPTICAL FIBER CABLING OR PASSIVE OPTICAL NETWORK (PON)	5-6
5.4.2	BLOWN FIBER-OPTICS (ALTERNATE FIBER OPTIC CABLE INSTALLATION METHOD).....	5-7
5.5	CROSS-CONNECTION SYSTEM (CCS) CONNECTING HARDWARE	5-8
5.5.1	INSULATION DISPLACEMENT BLOCKS	5-8
5.5.2	PATCH PANELS	5-9
5.6	LOADS FED FROM UNINTERRUPTIBLE POWER SUPPLY (UPS).....	5-9
5.7	TELECOMMUNICATIONS ROOMS.....	5-9
5.7.1	GENERAL	5-9
5.7.2	SPACE FOR FUTURE EQUIPMENT	5-10

CHAPTER 5: TABLE OF CONTENTS

This page intentionally left blank.

CHAPTER 5: TELECOMMUNICATIONS INFRASTRUCTURE PLANT (TIP)

5.0 TELECOMMUNICATIONS INFRASTRUCTURE PLANT (TIP)

(NOTE – VA HAS IDENTIFIED TIP AS “REAL PROPERTY” OF A FACILITY, BUILDING OR PROJECT)

- (a) All TIP construction documents shall be reviewed and technically approved by SMCS 005OP2H3 before being released for bidding and construction ([Paragraph 1.3](#)).
- (b) Provide TIP system(s) and interfaces / interconnections and wire management functions as required by project. All inside TIP (backbone) cabling between the DEMARC, TER and TOR (if used), MCR and each TR shall be installed in conduit.
- (c) Refer to Master Construction Specifications - See [Paragraph 7.2.3](#) for specific document references.

5.1 TIP REQUIREMENTS

- (a) Mission Critical Facility(s) shall not have a single point of TIP failure if a catastrophic accident occurs (i.e. all TIP fiber-optic or TWP cables enters and exits the MCR or TR at the same point, etc.)
- (b) For non-Mission Critical facilities, a single primary source may be adequate; however, **consider two Service Provider sources** if LEC reliability is in question and it can be justified as cost-effective.
- (c) Ensure that required easements for utility conductors and equipment are provided in accordance with the requirements of the service provider. For Mission Critical facilities, it is required that there are two primary Service Provider sources, as electrically and physically separated as possible. If it is cost inhibitive or almost impossible for the Local Exchange Carrier to meet this requirement, the design professional shall inform the VA in writing of the situation, recommend solutions, and obtain VA’s authorization to deviate from this requirement. Refer to NFPA 99 and the PSDM for more information. Provide a cost opinion for the second utility service to aid VA in determining the cost-effectiveness of this requirement.
- (d) In renovation projects, the TIP shall be compatible with, properly interface and extend the facility’s existing TIP functions without derogation. Provide the new TIP system with a defined “extension” / “demarcation” point with appropriate “cross-connecting” hardware and show this point on the system drawings. Contact AHJ SMCS (See [Paragraph 1.3](#)) for approved method and equipment required for this point.

5.2 BACKBONE DISTRIBUTION

5.2.1 GENERAL

- (a) Backbone cabling systems provide the connections between service provider point of entry, DEMARC (or extended DEMARC) point, MCR and BUCR, antenna HE equipment room, PCR, ECC, ECR, EMCR, (and OSP’s EMCC if not a part of the EMCR), TRs and telecommunications enclosures. A backbone cabling system consist, as a minimum, of the

CHAPTER 5: TELECOMMUNICATIONS INFRASTRUCTURE PLANT (TIP)

following to comprise a complete and functional TIP cabling system: punch down and cross-connector blocks, patch panels, distribution backbone cabling sub-systems, and associated hardware including copper and fiber optic distribution cables, connectors, patch cables, “break out” devices and equipment cabinets, interface cabinets, radio relay equipment rack, and telecommunications enclosures.

- (b) Design backbone cabling systems for permanency, with flexibility for future changes, expansion as described herein, and to support maintenance.
- (c) Copper conductor balanced TWP cable is required. Aluminum, copper clad aluminum or copper clad steel conductors *are not permitted*. Terminate all interconnecting TWP pairs, fiber-optic strands or coaxial cables on patch panels or punch blocks.
- (d) Refer to [Paragraph 7.2.3](#) for additional requirements.

5.2.2 ROUTE DIVERSITY

- (a) Refer to the PSDM for pathway protections and routing requirements
- (b) Two (2) diverse route backbone cables shall be provided to the each Service Entrance, DEMARC, TER / TOR (if used), MCR and each TR.
- (c) Resilience is needed because the backbone is connected to systems identified as critical care performing life support functions and a loss of connections may severely impact delivery of essential services.

5.3 OUTSIDE PLANT CABLING

- (a) Service Provider cabling shall be installed underground, in concrete-encased ductbanks. Each ductbank shall contain ducts for planned future expansion, as well as 40% additional ducts for unplanned future expansion. Route ductbanks to avoid possible locations of future building foundations or other structures. To the extent practical, redundant cables should be physically separated and not routed in the same ductbank.
- (b) Require installation of locator ball, disc, or other tracker allowing service provider to locate conduit ends.
- (c) Require innerducts with pull line inside conduits designed for optical fiber cable installation.
- (d) Consider installation of metal conductor in nonmetallic conduit with optical fiber for locating purposes.
- (e) Conduit bend radius must be at least 10 times inside diameter of conduit.

5.3.1 BACKBONE TOPOLOGIES

- (a) Provide continuous inter-and/or intra-facility cable distribution system based on a hierarchal star topology compliant with ANSI/TIA-568-C.o.
- (b) At least one ER within each campus building.

CHAPTER 5: TELECOMMUNICATIONS INFRASTRUCTURE PLANT (TIP)

- (c) There shall be no more than two hierarchical levels of cross-connects in the backbone cabling. From the horizontal cross-connect (HC), no more than one cross-connect shall be passed through to reach the MC. Therefore, connections between any two HCs shall pass through three (3) or fewer cross-connect facilities.
- (d) The selected cable and system determine the maximum cable lengths. Cable lengths shall take into account patch cords and cross-connect jumpers. Cross-connect jumpers and patch cords in the MC or IC should not exceed 20 m (66 ft.).

5.3.2 CABLING TYPES

It may often be necessary to use more than one cable type for the backbone cabling.

5.3.2.1 Twisted-pair cabling (TWP):

- (a) It is recommend a minimum of 500 pair of TWP be provided FMS / OI&T service between the Entrance, DEMARC and TR's **Note:** Re-Verify all FMS, Patient Phones, Emergency Phones, FAX, analog emergency / signaling pairs required – **may need to be increased.**
 - (b) Allow for a minimum of 40 percent anticipated growth.
 - (c) Category 3; High pair count **NOTE:** Category 3 cabling information is **provided for reference to existing cable only.** Category 3 cabling is **NOT ALLOWED** in new or replacement VA Construction Projects.
 - (d) In existing Facility TIP - Category 3 cable should be limited only to analog voice and low-speed signaling applications up to a maximum of 16 MHz Voice cable length should be limited to 800 meters [2,525 feet]. It is **highly recommended that all** Category 3 cables **be removed and upgraded** to existing standards.
 - (e) Category 5e; four (4) pair or 25 pair up to 100 MHz
 - (f) Category 6; 250 MHz or Category 6A 500 MHz
- (NOTE:** Category 5e is recommended. Use higher category (e.g. 6 or 6A) for specialized powered systems technically approved by SMCS 005OP2HX3. H3H2, OI&T and FMS Services and the COR)

5.3.2.2 Multimode optical fiber cabling:

- (a) 62.5/125 micron (OM1); length 2,000 m [6,562 ft.] up to 155Mb/s
 - (b) 50/125 micron (OM3); length 300 m [984 ft.] up to 10 Gb/s
 - (c) 50/125 micron (OM4); length 550 m [1,804 ft.] up to 10 Gb/s, and 150 m [492 ft.] up to 100 Gb/s
- (NOTE:** 850nm laser-optimized 50/125 micron (OM4) is recommended for inter facility use; except, where 62.5 micron cables are the interface standard required between the facility and the local CO)

CHAPTER 5: TELECOMMUNICATIONS INFRASTRUCTURE PLANT (TIP)

5.3.2.3 Single-mode optical fiber cabling

- (a) OS1 (tight buffer); length 2,000 M [6,562 ft.] up to 100 Gb/s
- (b) OS2 (loose tube); OSP, length 10,000 M [32,808 ft.] up to 100 Gb/s

5.3.2.4 Coaxial cable (tree topology, trunk cables)

- (a) Series-11/U; 18 AWG (.823 mm²) stranded center conductor
- (b) Series-6; quad screen: less than 76 M [250 ft.]
- (c) 0.500 inch hard line or 0.750 inch hard line: OSP
(NOTE: Series-11/U is recommended)

5.4 OPTICAL FIBER CONSIDERATIONS

- (a) Verify requirements for connection to Service Provider's main point of demarcation (DEMARC) (AKA: Extended DMARC, ENTR). This point is owned by LEC or Service Provider and Service providers may require 62.5 micron optical fiber at DEMARC as it establishes a physical point where the service provider's responsibilities for service and maintenance end. In data networks, this point is called the NID.

(NOTE: Equipment required to convert to 62.5 micron Bell System Standard requirements is cost prohibitive)

- (b) Recommended between TR's:
 - OM4 multi-mode cable, containing, at minimum, 96 strands (48 pair) of fiber.
 - Single mode fiber 8.3mm optic cable, containing, at minimum, 48 strands (24 pair) of fiber.
- (c) Specify loose tube cable, which separates the individual fibers from the environment, or indoor/outdoor cables, for outdoor installation or any pathway which includes an outdoor run. Select tight buffered fiber cable or indoor/outdoor cables for indoor pathways.
- (d) Specify protective enclosures for Fiber optic cable slack. Size fiber cross connect on drawings to connect cables at termination points and allow for a minimum of 50 percent anticipated growth.

5.4.1 CENTRALIZED OPTICAL FIBER CABLING OR PASSIVE OPTICAL NETWORK (PON)

Centralized optical fiber cabling is a design alternative for installation of recognized optical fiber cabling in the horizontal with specialized active electronics. Centralized cabling must meet the requirements of ANSI/TIA-568-C.o. Before designing a centralized optical fiber cabling or PON obtain approval by SMCS 005OP2H3.

CHAPTER 5: TELECOMMUNICATIONS INFRASTRUCTURE PLANT (TIP)

5.4.2 BLOWN FIBER-OPTICS (ALTERNATE FIBER OPTIC CABLE INSTALLATION METHOD)

- (a) In areas with limited access to pathways, air blown fiber may be accepted as an alternate fiber optic cable installation method. Obtain approval for all Air blown fiber installation process during the project design stage(s) from VA's AHJ, Spectrum Management and COMSEC Service (SMCS-005OP2H3). After installation of MicroDucts, future cabling changes may be proprietary to a specific OEM.
- (b) The Blown Fiber-Optics installation process (also referred to as: air blown cable, air assisted cable, high pressure air blowing, cable jetting, etc., referred to as Blown Fiber-Optics herein) typically uses separate optical fiber cables along with separate flexible protective MicroDucts installed where the optical fiber cables can be blown in. Specify only jacketed optical fibers specific to the purpose of being blown throughout the Bundled MicroDuct system. Specifying correct jacket on optical fiber cable ensures it will hand shake with the air blowing process.
- (c) Include a riser drawing of the campus, buildings and floors. Show the TSER and TRs in each building on the riser. Identify every TR that will need air blown fiber.
- (d) Identify on riser fiber strand quantity and fiber type (i.e., singlemode, multimode) required at each TR (**Note** - Higher strand counts require larger MicroDucts).
- (e) Show fiber termination units at all locations where fiber is terminated.
- (f) Identify on the riser the quantity of MicroDucts needed to feed:
 - OSP distribution supplying a campus. Include locations that require maintenance holes (AKA Manholes), handholes and all other additional types of access points.
 - Each facility entrance.
 - Each floor TR.
- (g) Include divergent paths on riser where they are required.
- (h) MicroDucts pulled in conduit, may exceed the 40 percent fill for cables pulled within conduits.
- (i) Determine extent of redundancy desired. Design quantity of MicroDucts for 200%-300% growth by adding 1or 2 empty MicroDucts for every occupied MicroDuct.
- (j) Include an enclosed access point for mid-span blowing assistance on runs with a distance greater than 609 m [2,000 feet].
- (k) For segments that have extremely long distances larger MicroDucts may be necessary. If pathway & access points are dedicated to blown fiber, maintenance hole & handhole distances may be extended.

CHAPTER 5: TELECOMMUNICATIONS INFRASTRUCTURE PLANT (TIP)

- (l) Ensure proper protective tube/duct is specified with special attention given to bend radius. Pathway space for MicroDucts should consider the minimum bend radius of 20 times the cable diameter.
- (m) Identify Hazardous locations (Class I, II & II / Division 1 & 2 environments). Methods must be used to prevent the passage of flammable gases or vapors, flammable liquids, combustible dust, ignitable fibers or filings through MicroDucts. Show gas-blocking couplers to isolate classified areas from non-classified areas.
- (n) Size MicroDuct distribution units based on the number of MicroDucts to enter the unit.
- (o) Specify outdoor NEMA rated enclosures suitable for the site environmental conditions. Specify NEMA 4 and 4X enclosures and splice cases in areas where hosing and splashing environmental conditions exist. Specify NEMA 6 and 6P enclosures and splice cases in areas where temporary or long term flooded environmental conditions may exist.
- (p) When rack-mount fiber termination hardware is required, include wall-mount MicroDuct distribution unit near the rack and provide individual **MicroDucts** from the distribution unit to the fiber termination in the rack.

5.5 CROSS-CONNECTION SYSTEM (CCS) CONNECTING HARDWARE

Specify cross connects compliant with ANSI/TIA-568-C.2 for balanced twisted-pair cable and ANSI/TIA-568-C.3 for optical fiber cable.

5.5.1 INSULATION DISPLACEMENT BLOCKS

Specify for balanced twisted pair due to lower cost than patch panels.

- (a) 110(E) - STYLE
 - Up to 250 MHz
 - Unshielded
- (b) 66-STYLE (Category 3) (**NOTE:** Is included for existing information only as it ***IS NOT ALLOWED*** IN NEW OR RENOVATED VA Facilities).
 - Up to 16MHz
 - Voice only
- (c) BIX-STYLE
 - Up to 250 MHz
 - Not recommended
- (d) LSA-STYLE (AKA KRONE)
 - Up to 250 MHz
 - Not recommended

CHAPTER 5: TELECOMMUNICATIONS INFRASTRUCTURE PLANT (TIP)

(NOTE: 110-STYLE, Category 5e listed, IS THE MINIMUM RECOMMENDED FOR SINGLE PAIR TERMINATIONS)

5.5.2 PATCH PANELS

(a) Patch panels; balanced twisted pair

- 48 ports in single Rack Mounting Unit (RMU) recommended for projects with high density areas.
- When specifying angled patch panels reduce horizontal wire management.
- Only specify field configurable configuration where necessary due to project requirements.

(b) Patch Panels and Enclosures: Optical Fiber

Rack or wall mounted; determine size based on number of terminations with additional consideration given to:

- Slack storage.
- Pigtail splice termination.
- Splice tray.

(Note – cross connections must use optical fiber patch cords, not splices)

5.6 LOADS FED FROM UNINTERRUPTIBLE POWER SUPPLY (UPS)

(a) UPS equipment is necessary for FMS and OI&T electronic equipment or any equipment that performs critical functions and requires continuous regulated power for operation.

(b) At a minimum, the following loads should be protected by UPS equipment:

- DEMARC, TER / TOR (if used), MCR / MCOR equipment TER equipment (if used).
- TR equipment.
- HVAC control equipment.
- Other mission-essential equipment necessary for continuity of service that is not tolerant of the transfer time between utility and generator power.

(c) Refer to PSDM for running times and additional instructions.

5.7 TELECOMMUNICATIONS ROOMS

5.7.1 GENERAL

Refer to [Chapter 8.7](#) for additional requirements

(a) The location, protection, and access to TRs shall comply with the Physical Security Design Manual.

CHAPTER 5: TELECOMMUNICATIONS INFRASTRUCTURE PLANT (TIP)

- (b) Physical area shall be according to the OI&T Design Guide.
- (c) TRs shall be located above the 100 year Flood Plain Elevation.
- (d) TRs shall not be located beneath toilets, showers, laboratories, kitchens, sinks, open courtyards, planters, roof drain leaders, water fountains, or other areas where water service or displays is provided.
- (e) Equipment spaces shall be designed to allow maintenance equipment access, and to facilitate equipment replacement without significant demolition and reconstruction. Do not install TRs in or adjacent to elevator equipment, electrical, surgical / operating, MRI and DEMARC rooms; or, patient care or other like areas.
- (f) Any pipe or duct system foreign to the communication room installation shall not enter or pass through that space. The design professional shall ensure that foreign piping such as water pipes, steam pipes, medical gas pipes, sanitary waste pipes, roof drains, A/C ducts, and other unrelated piping systems containing liquids or gases are not installed, nor pass through, rooms. Sprinkler piping shall not be routed through communication rooms, unless it serves to protect the installation.
- (g) Coordinate with Mechanical Engineer for sufficient mechanical ventilation or cooling system to maintain the indoor temperature range required for proper operation of the equipment.
- (h) No telecommunications equipment, other than telecommunications outlets, shall be placed within electrical rooms.
- (i) Rooms shall stack vertically, and shall not be further than 500 ft. [15 M] apart, to limit maximum cable length to approximately 295 ft. [90 M] that includes ALL connections / connector, patch cable losses.

5.7.2 SPACE FOR FUTURE EQUIPMENT

- (a) Rooms that contain freestanding electrical equipment shall be sized so that sufficient space is provided to add one additional section to each unit of freestanding equipment.
(Note: Refer to the OI&T Design Guide for specific telecommunications area design plates in order to meet the minimum used and expandable space requirements)
- (b) Shall have a minimum of 40% spare wall space for future installation of equipment.

CHAPTER 6: TABLE OF CONTENTS

**CHAPTER 6:
TABLE OF CONTENTS**

6.0	GENERAL	6-3
6.0.1	SERVICE PROVIDERS.....	6-3
6.1	ENTRANCES	6-3
6.1.1	DEMARC ROOM	6-3
6.1.2	ANTENNA EQUIPMENT	6-4
6.1.3	FACILITY BUILDING ENTRANCES	6-5
6.1.4	BONDING TO GROUND.....	6-6

CHAPTER 6: ENTRANCE FACILITIES

This page intentionally left blank.

CHAPTER 6: ENTRANCE FACILITIES

6.0 GENERAL

Entrance facilities accommodate equipment and support functions for distribution of OSP, OI&T and FMS services (fiber and copper) to connect buildings outside the facility and provide services from off-campus service providers. This functional area includes DEMARC and Antenna HE Equipment Rooms.

6.0.1 SERVICE PROVIDERS

- (a) DEMARC is the Service Provider's (SP) main point of demarcation (AKA: Extended DMARC, ENTR) and therefore is owned by LEC or Service Provider and establishes a physical point where the service provider's responsibilities for service and maintenance end. In data networks, this point is called the NID.
- (b) Coordinate design with the SP including terminating space on wall, power requirements, conduits (quantity, size and depth) to meet or exceed all LEC or SP requirements. This requirement also is applicable to any Service Provider Demarcation Point (SPDP) not owned by the LEC or service provider, but designated by Government as the point within facility considered the DEMARC.
- (c) See Paragraph [1.5.1 for Service Provider Caution](#).

6.0.1.1 SHARED PATHWAYS

Service providers may need to share conduits with VA cabling to reduce cost. Provide innerducts in these cases to reduce possibility of damage to both sheaths from abrasion.

6.1 ENTRANCES

6.1.1 DEMARC ROOM

- (a) **Refer to Paragraph 8.4** for additional information.

This room provides space for the initial termination of services brought to the facility by outside providers, such as telephone providers, data providers, MATV/CATV providers, security providers, etc. Two (2) Demarc Rooms are required for mission critical facilities (see NFPA 99, Chapter 7 herein, OI&T Design Guide and VA Physical Security Design Manual (PSDM)).
- (b) Not less than two (2) physically separated service entrance pathways into mission critical facilities shall be required. To reduce the risk of injury or damage to the building or occupants from outside plant cable EF shall be as close as practicable to the building communication service entrance point.
- (c) In a facility where the primary data center is located remotely two EFs and redundant telecommunications service entrances shall be provided.
- (d) Do not install underground utilities such as electrical water gas and sewer below the EF.
- (e) Physical area shall be according to the OI&T Design Guide.

CHAPTER 6: ENTRANCE FACILITIES

6.1.2 ANTENNA EQUIPMENT

(a) Head End (HE) Equipment Room

- Refer to [Section 8.3](#) for additional requirements.
- Physical area shall be according to the OI&T Design Guide.
- Antenna HE Equipment Room contains head-end cabinets for RF antenna-based OSP and FMS systems (i.e., MATV/CATV, Two-Way Radio, RPS, HF, M/W, TVRO, V-SAT, Satellite Phone / Emergency Connections, etc.). The room shall be sized for a minimum of six (6) separate systems, and four (4) future systems
- Antenna HE Room shall be located in close proximity to the antennae and provide a direct conduit path to limit outside plant cable length in the building. Refer to [Appendix B](#) for typical conduit paths and SMCS (005OP2H3) for additional conduit requirements.
- Coordinate power and HVAC requirements of active electronics with electrical and mechanical engineer(s).
- Provide provisions for Circulating Communication Grounding System (CCGS - see [Paragraph 7.3.3](#) and [Appendix A](#)); **also**, see Specification 27 05 26 - Grounding and Bonding for Communications Systems) for bonding room equipment, cable shields, equipment connection and mounting hardware and conduits. DO NOT CONNECT TO OR USE THE LPGS OR ELECTRICAL GROUND (EG) SYSTEMS.
- Provide provisions for Antenna HE Room Physical Security. See [Paragraph 8.2.4](#) herein for typical security requirements and contact SMCS (005OP2H3) for additional requirements.
- Size should be based upon number of systems and the required equipment. Constructions allow expandable area for growth.
- Locate away from RFI, EFI and EM noise sources including high voltage power conductors. See PSDM for required distances.
- TIP interconnections between systems may use a variety of media and an adequate quantity of conduits shall be installed to provide required separation and isolation (see [Chapter 7](#) and [Appendix B](#) for typical conduit paths). At a minimum, provide:
 - i. Raintight roof and or wall conduit feedthroughs to accommodate each RF unit antenna coaxial, fiber and / or TWP cables.
 - ii. Provide conduit connections to TER / TOR (if used), MCR, PCR, EMCR's SCC (and OSP's EMCC if not a part of the EMCR) and ECR; and, contact SMCS (005OP2H3) for additional requirements.
 - iii. Do not locate in DEMARC, TER / TOR (if used), MCR, TR, Electrical, Elevator and Mechanical Rooms, or like locations.

(b) Antenna Farm

- Provide as close to the Antenna HE Room as practicable.

CHAPTER 6: ENTRANCE FACILITIES

- Provide area with Physical Security Access Control (see [Paragraph 8.2.4](#) for general requirements) **and** contact SMCS (005OP2H3) for additional requirements.
- Provide provision for an external Lightning Protecting Grounding System (LPGS – see [Paragraph 7.2.8.1](#), [Appendix A](#) and Specification 26 41 00 – Facility Lightning Protection) for bonding external Antenna Farm, Antenna Equipment, Mounts, Hardware, Coaxial Cable Shields, Lightning Protection Devices and a direct path to certified earth ground. DO NOT CONNECT TO OR USE THE CCGS OR EG SYSTEMS.
- Conduits: provide necessary conduits to satisfy antenna farm requirements. Contact SMCS (005OP2H3) for specific requirements.
- Provide roof strengthening to accommodate each TVRO, V-SAT or through roof antenna mast necessary to accommodate each satellite and radio unit’s external antenna equipment.
- Provide wall strengthening to accommodate each antenna mast necessary to accommodate each satellite and radio unit’s external antenna equipment.
- Co-ordinate with the Project’s Roof Contractor to insure all necessary water-proofing components (i.e. pitch pockets, etc.) are identified and installed by the roof contractor. The Telecommunications Contractor *is not allowed* to make penetrations or modifications to the roof.

6.1.3 FACILITY BUILDING ENTRANCES

6.1.3.1 AERIAL ENTRANCES

- (a) Place a pole near the building to limit overhead cable pulling tension on support structures.
- (b) Meet or exceed clearance requirements of National Electrical Safety Code (NESC) with special consideration to electrical power and traffic.
- (c) Terminate conduits 10 cm [4”] below ceiling.

For additional safety information refer to the latest edition of BICSI’s Outside Plant Design Reference Manual (OSPDRM), local codes and regulations. (**NOTE:** Buried conduit is preferred to aerial cables)

6.1.3.2 UNDERGROUND ENTRANCES

- (a) Design conduits entering from below grade to extend 7.62cm (3 inches) a.f.f..
- (b) Entrance conduits shall be secured to structure to withstand exterior cable pulling procedures.
- (c) Seal both ends of conduits to prevent gases or moisture from entering the building.
- (d) Where applicable, base conduit depth on published 50 year frost penetration depth.

CHAPTER 6: ENTRANCE FACILITIES

6.1.3.3 MAINTENANCE HOLES (MH) (FORMERLY MANHOLES)

- (a) Size based upon size of conduits, number of cables and routes served.
- (b) Avoid locating MH in roads with traffic.
- (c) Identify other underground services (sprinkler system, outdoor lighting, electric, gas, water, sewer) before locating MH.
- (d) Avoid sharing MH with electrical power wiring.
- (e) Conduit shall enter MH on opposite ends of MH.
- (f) Do not mark cover easily identifying services.

6.1.4 BONDING TO GROUND

- (a) Provide a means to bond metal conduits and cable sheaths to ground where they enter building.
- (b) Provide protective devices (i.e. gas tubes, etc.) on all conductive cables at the point of entrance. Do not locate protective devices near flammable material or in hazardous environments. Limit potential differences between communications circuits and other metallic systems by selecting location with shortest grounding conductor practical.
(NOTE: Fuseless type protectors, where permitted by NEC, are preferred)

CHAPTER 7: TABLE OF CONTENTS

CHAPTER 7: TABLE OF CONTENTS

TELECOMMUNICATIONS SYSTEMS

TELECOMMUNICATIONS CABLE PATHWAYS, WIRING AND CABLES, AND INFRASTRUCTURE PLANT (TIP); SPECIAL TELECOMMUNICATIONS SYSTEMS

Note: Chapters 7 and 8 contain like references, guidelines and instructions that refer to each specific system/function. These "like" descriptions have been cross-referenced throughout both chapters to reduce redundancy. Additionally, each chapter contains acronyms that pertain to both; these have been combined in the beginning of Chapter 7.

7.0	GENERAL	7-3
7.1	SPECIAL COMMUNICATION SYSTEMS	7-3
7.2	SPECIAL COMMUNICATION SYSTEMS IDENTIFICATION	7-3
7.2.1	GENERAL	7-3
7.2.2	COMMUNICATIONS INFRASTRUCTURE SYSTEMS	7-3
7.2.3	TELECOMMUNICATIONS INFRASTRUCTURE PLANT (TIP)	7-3
7.2.4	COMMUNICATIONS CIRCULATING GROUNDING SYSTEM (CCGS) – (REFER TO PG-18-10, EDM & OI&T DESIGN GUIDE, TELECOMMUNICATIONS GROUNDING BUSS (TGB)	7-5
7.2.5	COMMUNICATIONS LIGHTNING PROTECTION GROUNDING SYSTEM (LPGS)	7-5
7.2.6	LIFE SAFETY SYSTEMS (SOMETIMES CLASSIFIED AS “CRITICAL SERVICE”)	7-9
7.2.7	EMERGENCY SYSTEMS	7-11
7.2.8	PATIENT, STAFF AND PUBLIC SAFETY SYSTEMS	7-19
7.2.9	OTHER SPECIAL COMMUNICATIONS SYSTEMS	7-22
7.2.10	SPECIAL COMMUNICATIONS “SEPARATED” SYSTEMS	7-26
7.2.11	OI&T SYSTEMS REQUIRING AHJ SMCS 005OP2H3 CO-ORDINATION ..	7-35
7.2.12	SPECIAL MEDICAL COMMUNICATIONS SYSTEMS (SMCS)	7-37

CHAPTER 7: TELECOMMUNICATIONS SYSTEMS

This page intentionally left blank.

CHAPTER 7: TELECOMMUNICATIONS SYSTEMS

7.0 GENERAL

Contact VA's Low Voltage Communications Systems' AHJ, Spectrum Management and COMSEC Service, (SMCS-005OP2H3) for technical assistance with systems design, engineering, preparation and review of construction documents, installation, proof of performance testing and VA certification for Special Communications Systems.

7.1 SPECIAL COMMUNICATION SYSTEMS

- (a) Special Systems are identified as those telecommunications systems that are not telephone (aka "voice"), data, or fire alarm (or related functions).
- (b) The following *are typical* Special Communications Systems found in VA Facilities for OSP and FMS services with the Facility TIP shared with OI&T.
- (c) If a project specific OSP or FMS Special Communications System(s) is required, that is not listed or otherwise identified herein, ***or*** in CFM's TIL; ***refer to Paragraph 1.9 for specific instructions***; ***and***, immediately contact VA's AHJ SMCS-005OP2H3 for specific technical assistance and contract specification development requirements.

7.2 SPECIAL COMMUNICATION SYSTEMS IDENTIFICATION

7.2.1 GENERAL

Provide systems described in this manual as determined by project requirements. Not all systems may be required, and not all required systems may be listed below.

7.2.2 COMMUNICATIONS INFRASTRUCTURE SYSTEMS

7.2.3 TELECOMMUNICATIONS INFRASTRUCTURE PLANT (TIP)

(Refer to PG-18-10, EDM, OI&T DESIGN GUIDE, SPACE PLANNING, PAGE 2-3, PSDM and [Paragraph 5.0](#) herein).

(NOTE - VA IDENTIFIED AS AN ESSENTIAL COMMUNICATIONS SYSTEM SHARED BETWEEN FMS AND OI&T)

- (a) Provide a complete and separate NRTL (e.g. UL-864) listed and labeled and TIA minimum Category 5E compliant TIP that functions within ANSI and TIA 569B envelopes for "smart commercial buildings" insuring FMS Emergency Voice Service minimum operating parameters and Data Service Reliability identified herein.
- (b) Ensure each Service Provider is contacted for compliance requirements and perform site survey for existing TIP installation and interfacing ([Paragraph 1.6.1](#)).
- (c) TIP head end (HE) equipment will be located in the physically secured FMS areas of the DEMARC, Antenna HE Room, PCR, PCR, ECR, EMCR SCC (and OSP's EMCC if not a part of the EMCR), TER / TOR (if used), MCR, MCOR, and each TR (Re: OI&T Design Guide, PG-18-10, and [Appendix B](#) herein) and other locations as approved during the Project

CHAPTER 7: TELECOMMUNICATIONS SYSTEMS

Design and Technical Reviews by SMCS 005OP2H3 at the beginning and throughout the project. Connections to the MCR must be approved by the AHJ.

- (d) Refer to the following VA Master Specifications (**Note** – all of these documents **MUST** be used on every project) in order to provide a complete TIP installation:
- 27 05 11 Requirements for Communications Installations.
 - 27 05 33 Raceways and Boxes for Communications Systems.
 - 27 10 00 Control, Communication and Signal Wiring.
 - 27 11 00 Telecommunications Room Fittings.
 - 27 15 00 Communications Structured Cabling.
- (e) Data Service Reliability:
- The TIP must conform to the Uptime Institute’s developed system for classifying the expected reliability of Data Centers, TER (if used) and MCRs based on designated facility use, how the rooms were constructed, types of equipment used, and how services are expected to be delivered. Four (4) Tier Levels are designated and high-level characteristics, along with expected reliability was indicated for each Tier (Refer to PG-18-12, OI&T Design Guide, Page 2-15 for these detail requirements).
 - **Voice Systems Minimum Operational Requirements:**
 - i. **Voice System Levels of Reliability:**

The TIP must conform to the Bell System developed system for classifying the **expected reliability of Voice System requirements** in Three (3) Tier Levels designated for high-level characteristics, along with expected reliability for each Tier (Refer to PG-18-12, OI&T DG, Pages 2-15,16 & 17; and, Table 2.2 for detail requirements).
 - ii. **Emergency Voice System Minimum Service (AKA Traffic) Grade:**

The TIP must conform to the Bell System developed system for classifying the expected **minimum Traffic (AKA Service) Grade(s) of Emergency Voice Systems** service designated for high-level characteristics (Refer to PG-18-12, OI&T DG, Page 17 and Table 2.2 for detail requirements. Pay particular attention to the **specific system minimum** Mean Time Between Failure (MTBF) 99.999% requirement ***that cannot*** be waived for Life Safety, Critical Service, Emergency and Public Safety FMS systems.

CHAPTER 7: TELECOMMUNICATIONS SYSTEMS

7.2.4 COMMUNICATIONS CIRCULATING GROUNDING SYSTEM (CCGS) – (REFER TO PG-18-10, EDM & OI&T DESIGN GUIDE, TELECOMMUNICATIONS GROUNDING BUSS (TGB))

(**Note** - VA identified CCGS as an essential safety system that is separate from the Electrical Grounding (EG) and Lighting Protection Grounding System (LPGS) - RE [APPENDIX A](#))

- (a) Provide a complete and separate CCGS compliant with TIA-607-B and IEEE STD 1100-2005; plus NFPA 780-2004; National Electric Code and UL 467-07 (Re [Paragraph 4.1](#) for additional requirements).
- (b) The CCGS head end point is the Facility's MGE and then circulates throughout the Facility to the DEMARC, Antenna HE Room, PCR, ECR, EMCR SCC (and OSP's EMCC if not a part of the EMCR), TER (if used) / TOR (if used), MCR / MCOR and each TR's TGB equipment that will then "span out" within each area in the recommended practices of the aforementioned AND local commercial building code(s) ensuring all communications equipment and systems are properly grounded as approved during the Project Design and Technical Reviews by SMCS 005OP2H3 at the beginning and throughout the project.
- (c) Refer to CFM VA Master Specification 27 05 26 - Grounding and Bonding for Communications Systems installation requirements.

7.2.5 COMMUNICATIONS LIGHTNING PROTECTION GROUNDING SYSTEM (LPGS)

(**NOTE** - VA HAS IDENTIFIED THE LPGS AS AN ESSENTIAL SAFETY SYSTEM THAT IS SEPARATE FROM THE CCGS AND EG SYSTEMS. (REFER TO [APPENDIX A](#)))

- (a) Provide a complete and separate external LPGS compliant with NFPA 780-11 and NFPA 70 and UL Standards 96-05 and 96A-07. Additionally, comply with UL standards 96-05 and 96A-07 (Re to [Paragraphs 4.1](#) and [4.3.7](#) for additional requirements).
- (b) The LPGS HE location is the Facility's Main Building Exterior Antenna Cable Entrance Point to the Antenna HE Room that connects all external Communication Antenna Farm Equipment together then routes the consolidated connection(s) in the most direct path to an exterior earth ground ensuring all external Antenna Farm Equipment and Systems are properly grounded according to the aforementioned **and** local commercial building code(s) as approved during the Project Design and Technical Reviews by SMCS 005OP2H3 at the beginning and throughout the project.
- (c) Refer to:
 - CFM VA Master Specification 26 41 00 – Facility Lightning Protection.
 - Motorola Inc., Radio Manual R-56 – Standards and Guidelines for Communication Sites. (Manual R-56 Standards and Guidelines for Communications Sites, ID # 68P81089E50-B (reference used by

CHAPTER 7: TELECOMMUNICATIONS SYSTEMS

permission); to obtain a copy, contact your local Motorola Representative, or Motorola Customer Care 800-814-0601).

7.2.5.1 Special Communications Antenna Farm

Provide all outside antenna farm items with a LPGS (See paragraph 7.2.5), TIP cabling including TCO (See paragraph 7.3.3) and CCGS (See paragraph 7.2.4) systems where required; and, Incorporates the following minimum equipment:

(a) Antennas

- **Radio:**

- i. UHF,
- ii. HF Radio,
- iii. M/W Radio,
- iv. Fixed Satellite radio,
- v. MATV,
- vi. RED,
- vii. Helicopter Operations, and
- viii. Other identified specialized antenna(s) to meet project needs.

- **Satellite:**

- i. TVRO Satellite TV,
- ii. Satellite Radio-Telephone,
- iii. **(WHEN APPROVED)** Earth / Ground Station Satellite TV.
- iv. V-SAT, Voice and Data, and
- v. Other identified specialized equipment to meet project needs.

(b) Antenna Electrical / Electronic Equipment.

- Pre-amplifiers,
- Converters,
- Equalizers,
- Lightning arrestors,
- FAA Hazzard Marking / Lighting,
- Helicopter Operations, and
- Other identified specialized equipment / system to meet project needs.

(c) Mounting, Anchoring and Support Equipment:

- Mast / Poles – typically building wall / through roof attached (Provide proper building strengthening when attached to building).
- Triangular Masts:
 - i. Building attached (Provide proper building strengthening when attached to building),
 - ii. Guyed,
 - iii. Free Standing, and
 - iv. FAA Hazzard Marking / Lighting.

CHAPTER 7: TELECOMMUNICATIONS SYSTEMS

- **(WHEN APPROVED)** Towers:
 - i. Self-Supporting,
 - ii. Guyed, and
 - iii. FAA Hazzard Marking / Lighting.
- Satellite:
 - i. V-SAT – roof or ground,
 - ii. TVRO – roof or ground, and
 - iii. **(WHEN APPROVED)** Earth / Ground – Ground Station.
(**Note** – when installed on roof, provide roof strengthening according to Antenna OEM and local building codes)
- M/W:
 - i. Pole, mast triangular for smaller units, and
 - ii. **(WHEN APPROVED)** Tower only for larger units.
(**Note** – when installed on roof, provide roof strengthening according to Antenna OEM and local building codes)
- (d) Security: provide secured area entry from / to:**
 - Building inside Penthouse / Antenna HE Room to Antenna Farm Roof Area,
 - Building outside to building inside and Antenna Farm Roof Area, and
 - **(WHEN APPROVED)** Stand-alone outside equipment building / shelter entry / exit.
- (e) Complete and certified grounding:**
 - LPGS for all outside Antenna Farm equipment:
 - Directly connected to earth ground,
 - NOT connected to the CCGS and EGS, and
 - CCGS for external building / shelter (when used).
- (f) (WHEN APPROVED) external stand-alone building / shelter.**
 - Location:
 - i. A dedicated penthouse, mechanical room (not elevator or electrical) and roof areas are required.
 - ii. Comply with Antenna Head End Room for internal equipment / systems, per OI&T Design Guide and PSDM.
 - iii. Rooms **shall *not* be located:**
 - Directly below or adjacent to laboratories, kitchens, laundries, fountains, toilets, showers, or other areas where water service is provided (i.e. facility entrance with water display(s), etc.).
 - In the elevator equipment room, next to or in an electrical room, MCR, TR, MRI room, surgical - operating room, recovery room, medical recovery room and other treatment areas, in patient care areas, or below the Base Flood Elevation.

CHAPTER 7: TELECOMMUNICATIONS SYSTEMS

- **Lightning for rooms and equipment building / shelter.**
 - i. Electrical Connection(s), UPS, Location and Security for all locations - comply with EDM and PSDM.
 - ii. Cable and Pathways for rooms and equipment building / shelter – comply with OI&T DG, TMD and EDM.
 - iii. Wire Management for rooms and equipment building / shelter – comply with TDM and PSDM.
- **Physical Security for rooms, equipment building / shelter.**
 - i. Provide room physical security the same as the Antenna HE Room.
 - ii. Provide external building / shelter physical security:
 - I. Outside the building / shelter - provide physical security per Motorola Technical Manual R-56.
 - II. Inside the building / shelter ***and*** at each outside entrance to the area - provide physical security the same as required for the Antenna HE Room.
- (g) ***DO NOT*** PROVIDE CABLES, WIRES AND TIP CONFIGURATION THAT WILL PRESENT ***A ONE POINT OF FAILURE CONDITION***.
- (h) For antenna farm external equipment / area, see Motorola Inc., R-56 – Manual and Guidelines for Communications Sites and Equipment Shelters.
- (i) Wireless Add-On Systems must be compliant with Paragraph 3.2.2; Wi-Fi Add-On Systems are not allowed.
- (j) Contact AHJ SMCS 005OP2H3 for design, engineering, technical, installation and certification assistance in developing a specialized TPD or Technical Specification when an Antenna Farm is required for the facility.

7.2.5.2 CFM'S other Special Communications System's Infrastructure Requirements

- (a) Solicitation for Offers (SFO) – a copy may be obtained at CFM's TIL at: <http://www.cfm.va.gov/til/dGuide/dgLBOPC-09-SFOTemplate.pdf>
 - The site, site improvements, building, interior spaces, finishes, Lessor-furnished equipment and special construction shall be provided in accordance with the SFO, all applicable Federal requirements, local Building Codes and ordinances, and applicable utility company requirements (Re Paragraphs 1.5.1, 6.1.1 and 7.2.8.2).
 - The offeror shall design and construct a building to suit the Government's requirements.
 - i. VA may consider space in existing buildings of sound and substantial construction which can be made adaptable as modern office and outpatient space; if, not in a new building.

CHAPTER 7: TELECOMMUNICATIONS SYSTEMS

- ii.** The space offered must be in a building that has undergone, or will undergo by occupancy, restoration of adaptive reuse for office and outpatient space with modern conveniences
- The offeror shall populate the provided facility with item that is approved by the Contracting Officer with technical concurrence from SMCS.
 - i.** One area of Lessee (VA) required items is several Telecommunications Systems.
 - ii.** Contact AHJ, SMCS 005OP2H3 at the beginning and throughout the project for technical assistance and VA Certification requirements (Re Paragraph 1.3).
- (b)** Refer to CFM Master Construction Specification SECTION 27 05 61 – Leased Space, Communications Equipment and Systems for installation requirements.
- (c)** Comply with CFM’s OI&T DG, PSDM, TDM and EDM.

7.2.6 LIFE SAFETY SYSTEMS (SOMETIMES CLASSIFIED AS “CRITICAL SERVICE”)

7.2.6.1 NURSE CALL AND CODE BLUE (NCS)

(**NOTE** - VA HAS IDENTIFIED NCS AS AN LIFE SAFETY COMMUNICATIONS SYSTEM)

- (a)** Comply with FCC and OSHA’s Safety of Life Restrictions; see **Paragraph 3.3.4** for this information.
- (b)** Provide a complete *and* separate UL 1069 listed and labeled NCS, TIP (Re **paragraph 7.2.3**) including TCO and CCGS (Re **Paragraph 7.2.4**) sub-systems with position identification (ID).
- (c)** NCS HE equipment will be located in the FMS portion of the TR(s) closest to the area(s) served (Re OI&T Design Guide). Connections to the physically secured FMS Area of the MCR must be approved during the Project Design and Technical Reviews by AHJ SMCS 005OP2H3 at the beginning and throughout the project.
- (d)** NCS Life Safety Code redundant remote enunciation shall be directly to the PCR and TOR (if used) MCOR; or as approved by AHJ SMCS 005OP2H3 during the Project Design and Technical Reviews by SMCS 005OP2H3 at the beginning and throughout the project. Connections to the MCR and TR must be approved by the AHJ.
- (e)** Wireless Add-On Systems must be compliant with **Paragraph 3.2.2** ; Wi-Fi Add-On Systems are not allowed.
- (f)** Refer to CFM VA Master Specification 27 52 23 – Nurse Call and Code Blue Systems for installation requirements.
- (g)** Provide Emergency NCS Stations in non-patient-ward toilet areas; and as approved by SMCS 005OP2H3, at the following locations:

CHAPTER 7: TELECOMMUNICATIONS SYSTEMS

- Dental Service (if not covered by a hands-free telephone or stand-alone emergency intercom system)
- Drug Dependency Treatment Clinic
- Genitourinary Clinic
- Nuclear Medicine
- Oncology Clinic/Area (if not covered by a Nurse Call or Code One/Blue system)
- Dialysis Clinic (if not covered by a Nurse Call or Code One/Blue System)
- Radiology Clinic (if not covered by a Nurse Call or Code One/Blue System)
- Emergency Room (if not covered by a Nurse Call or Code One/Blue System)
- Intensive Care (ICU, CCU) Units (if not covered by a Nurse Call or Code One/Blue System)
- Stepdown Units (if not covered by a Nurse Call or Code One/Blue System)

7.2.6.2 PUBLIC ADDRESS (PAS is sometimes included with Mass Notification System for specific function(s))

(NOTE - VA HAS IDENTIFIED PAS AS AN EMERGENCY COMMUNICATIONS SYSTEM AND PERFORMS THE PRIMARY FACILITY NFPA LIFE SAFETY CODE BLUE TEAM NOTIFICATION)

- (a) Comply with FCC and OSHA's Safety of Life Restrictions; see [Paragraph 3.4.4](#) for this information.
- (b) Provide a complete *and* separate UL - 813 listed and labeled PAS, TIP (Re [Paragraph 7.2.3](#)) including TCOs and CCGS (Re [Paragraph 7.2.](#)) systems. The PAS will perform the Primary NFPA-101, Life Safety Code - Code Blue required redundant notification(s) in an "all call-executive override" functional environment shall be the TOR (if used) MCOR and PCR or as approved by the AHJ. Also, the PAS will allow each sub-area receptionist to address their specific waiting / working area(s) during non-emergency conditions.
- (c) PAS HE equipment will be located in the PCR, a dedicated room next to the PCR or the FMS portion of a TR closest to the PCR. Connections to the secured FMS area of the MCR must be approved during the Project Design and Technical Reviews by SMCS 005OP2H3 at the beginning and through-out the project.
- (d) The PAS will be remote controlled and operated by the Police Service from the SMS in the PCR and EMOR's SCC OR as approved by SMCS 005OP2H3.
- (e) Connections to the MCR and TR must be approved by the AHJ.
- (f) Wireless Add-On Systems must be compliant with [Paragraph 3.2.2](#); Wi-Fi Add-On Systems are not allowed.

CHAPTER 7: TELECOMMUNICATIONS SYSTEMS

- (g) Refer to CFM VA Master Specification 27 51 16 – Public Address and Mass Notification Systems for installation guidelines.
- (h) Provide a PA system that includes a speaker volume control in each NS, Multipurpose, Break, Administrative, Recreation Room and as approved by SMCS 005OP2H3.

7.2.6.3 RADIO PAGING (RPS), Re Physical Security Design Manual for VA Facilities, Paragraph 9.3.6, Pages 9.7-9.8

(NOTE - VA HAS IDENTIFIED RPS AS AN EMERGENCY COMMUNICATIONS SYSTEM AND THE SECONDARY FACILITY CODE BLUE TEAM NOTIFICATION SYSTEM)

- (a) Provide a **separate** FCC Part 47 Listed, labeled **AND** VA/NTIA Licensed RPS with outside antenna(s) and antenna farm (Re Paragraph 7.2.5.1), LPGS (Re Paragraph 7.2.5), TIP (Re Paragraph 7.2.3) including TCO's and CCGS (Re Paragraph 7.2.4) systems. The RPS will perform the **Secondary** NFPA-101, Life Safety Code - Code Blue redundant voice and ID notification(s) to the Code Blue Team's via VA owned radio paging system in an "executive override" functional environment.
- (b) RPS HE equipment will be located in the Antenna HE Room (Re OI&T Design Guide) with remote control directly from the SMS in the PCR and EMCR's SCC (and OSP's EMCC if not a part of the EMCR) and be controlled and operated by the Police Service as approved during the Project Design and Technical Reviews by AHJ SMCS 005OP2H3 at the beginning and during the project.
- (c) Redundant Code Blue Notification shall be the TOR (if used) MCOR and PCR; or, as approved by the AHJ and be controlled and operated by the Police Service. Connections to the MCR must be approved by the AHJ.
- (d) Wireless Add-On Systems must be compliant with Paragraph 3.2.2; Wi-Fi Add-On Systems are not allowed.
- (e) Refer to CFM VA Master Specification 27 32 41 – Two Way Radio Equipment and Systems for installation requirements.

7.2.7 EMERGENCY SYSTEMS

7.2.7.1 EMERGENCY NOTIFICATION / COMMUNICATION (EVNS)

(NOTE - VA has identified EVNS as an Emergency Communications System)

- (a) Provide a complete and separate UL 681 compliant EVNS with position ID directly connected to and controlled by the SMS in the PCR and be controlled and operated by the Police Service and EMCR's SCC (and OSP's EMCC if not a part of the EMCR), TIP (Re Paragraph 7.2.3) including TCO's and CCGS (Re Paragraph 7.2.4) systems. Provide a companion SSTV System if the EVNS does not have an integrated video component.
- (b) EVNS HE equipment will be located in the PCR, a dedicated room by the PCR or the FMS area of a TR closet to the PCR as approved during the Project Design and Technical Reviews by AHJ SMCS 005OP2H3 at the beginning and throughout the project.

CHAPTER 7: TELECOMMUNICATIONS SYSTEMS

- (c) The EVNS is controlled by the EVCS where the two systems may be combined at the approval of the AHJ. Connections to the Facility's physically secured FMS area in the MCR and TR must be approved by the AHJ.
- (d) Wireless Add-On Systems must be compliant with Paragraph 3.3.2; Wi-Fi Add-On Systems are not allowed.
- (e) Refer to CFM VA Master Specification 28 52 31 Emergency Call System for installation requirements.

7.2.7.2 DURESS ALARM EMERGENCY NOTIFICATION (ENS)

(NOTE - VA HAS IDENTIFIED ENS AS PATIENT, PUBLIC AND STAFF EMERGENCY / SAFETY COMMUNICATIONS SYSTEM)

- (a) Provide ENS system(s) as required.
- (b) Under no circumstance shall the VoIP system be used to provide duress alarm functions. The telephone (voice) STP or UTP circuits may be used with SMCS 005OP2H3 approval, provided that there are enough spare pairs to satisfy the telephone (voice) system installation and projected growth, and each system does not interfere with the other.
 - Provide a **complete and** separate UL 681 compliant ENS with position ID directly connected to the SMS in the PCR and EMCR's SCC (and OSP's EMCC if not a part of the EMCR) and be controlled and operated by the Police Service, TIP (Re [Paragraph 7.2.3](#)) including TCO's and CCGS (Re [Paragraph 7.2.4](#)) systems. Provide a companion SSTV System if the EVNS does not have an integrated video component.
 - ENS HE equipment will be located in the PCR, a dedicated room by the PCR or the FMS area of a TR closet to the PCR as approved during the Project Design and Technical Reviews by AHJ SMCS 005OP2H3 at the beginning and throughout the project. The EVNS is controlled by the EVCS where the two systems may be combined at the approval of the AHJ.
 - Connections to the Facility's physically secured FMS area in the MCR and TR must be approved by the AHJ.
- (c) Wireless Add-On Systems must be compliant with [Paragraph 3.2.2](#) ; Wi-Fi Add-On Systems are not allowed.
- (d) Refer to CFM VA Master Specification 28 26 00 – Electronic Personal Protection System for installation requirement.

7.2.7.3 TWO-WAY (Fixed and Portable) RADIO (TRS), (Re Physical Security Design Manual for VA Facilities)

(NOTE -VA HAS IDENTIFIED TRS AS AN EMERGENCY COMMUNICATIONS SYSTEM)

Provide a complete and separate FCC Part 47 Listed, labeled AND VA/NTIA Licensed TRS with outside antenna(s) and antenna farm (Re [Paragraph 7.2.8.1](#)),

CHAPTER 7: TELECOMMUNICATIONS SYSTEMS

LPGS (Re Paragraph 7.2.5), TIP (Re Paragraph 7.2.3) including TCO's and CCGS (Re Paragraph 7.2.4) systems. The TRS will perform emergency two way radio voice communications for the Facility's Police, Disaster/ Emergency Services and, other services as approved by the AHJ.

- (a) TRS HE equipment will be located in the Antenna HE Room (Re OI&T Design Guide) with remote control from the SMS in the PCR and EMCR's SCC (and OSP's EMCC if not a part of the EMCR) and the ECC and be controlled and operated by the Police Service, as approved by AHJ SMCS 005OP2H3 during the Project Design and Technical Reviews at the beginning and throughout the project.
- (b) Connections to the MCR and TR must be approved by the AHJ.
- (c) Wireless Add-On Systems must be compliant with Paragraph 3.2.2; *Wi-Fi Add-On Systems are not allowed*
- (d) Refer to CFM VA Master Specification 27 32 41 – Two way Radio Equipment and Systems for installation guidelines.
- (e) Contact AHJ AMCS 005OP2H3 for radio, FCC and FAA requirements for helicopter operations.

7.2.7.4 EMERGENCY TELEPHONE LINE BY-PASS MICROWAVE (M/W)

(NOTE -VA HAS IDENTIFIED M/W AS AN EMERGENCY COMMUNICATIONS SYSTEM AND THE BACKUP FACILITY LIFE SAFETY CODE BLUE TEAM NOTIFICATION SYSTEM)

- (a) Provide a **complete and separate** FCC Part 47 Listed, labeled ***AND*** VA/NTIA Licensed M/W with outside antenna(s) and antenna farm (Re Paragraph 7.2.8.1), LPGS (Re Paragraph 7.2.5), TIP (Re Paragraph 7.2.3) including TCO's and CCGS (Re Paragraph 7.2.4) systems. The M/W will perform emergency two way emergency FMS and telephone voice and secondary data tie line bypass (backup) in the event the Facility's hard wired tie line circuits fail for the Facility's Police, Disaster, Emergency and , other services as approved by the AHJ.
- (b) M/W HE equipment will be located in the Antenna H E Room (Re OI&T Design Guide) ***OR*** an outside standalone electronic equipment building separate from other Facility Buildings, with remote control from the SMS in the PCR, and EMCR's SCC (and OSP's EMCC if not a part of the EMCR) and be controlled and operated by the Police Service as approved by AHJ SMCS 005OP2H3 during the Design and Technical Reviews at the beginning and throughout the project. Connections to the MCR and TR must be approved by the AHJ.
- (c) Wireless Add-On Systems must be compliant with Paragraph 3.2.2 ; *Wi-Fi Add-On Systems are not allowed.*
- (d) Contact AHJ SMCS 005OP2H3 for technical assistance in developing a specialized Technical Purchase Description (TPD) or Technical Specification when a M/W is required by the facility.

CHAPTER 7: TELECOMMUNICATIONS SYSTEMS

7.2.7.5 EMERGENCY HIGH FREQUENCY TWO WAY RADIO (HF)

(NOTE - VA HAS IDENTIFIED HF AS AN EMERGENCY COMMUNICATIONS SYSTEM AND THE SECONDARY FACILITY CODE BLUE TEAM NOTIFICATION SYSTEM)

- (a) Provide a complete and separate FCC Part 47 Listed, labeled AND VA/NTIA Licensed HF with outside antenna(s) and antenna farm (Re [Paragraph 7.2.8.1](#)), LPGS (Re [Paragraph 7.2.5](#)), TIP (Re [Paragraph 7.2.3](#)) including TCO's and CCGS (Re [Paragraph 7.2.4](#)) systems. The HF will perform emergency two way over the air emergency voice and limited data signal to VACO, Region, VISN or other location approved by the AHJ in the event of a disaster (natural or man-made), for the Facility's Police, Disaster and Emergency Services and, other services as approved by the AHJ.
- (b) HF HE equipment will be located in the Antenna HE Room (Re OI&T Design Guide); OR an outside standalone electronic equipment building separate from other Facility Buildings, with remote control from the SMS in the PCR and EMCR's SCC (and OSP's EMCC if not a part of the EMCR) and ECC and be controlled and operated by the Police Service as approved by the AHJ during the Design and Technical Reviews at the beginning and throughout the project. Connections to the MCR and TR must be approved by the AHJ.
- (c) Wireless Add-On Systems must be compliant with [Paragraph 3.2.2](#); Wi-Fi Add-On Systems are not allowed.
- (d) Contact AHJ SMCS 005OP2H3 for technical assistance in developing a specialized TPD or Technical Specification when a HF system is required by the facility.

7.2.7.6 INTERCOMMUNICATION (ICS)

(NOTE - VA HAS IDENTIFIED ICS AS AN EMERGENCY COMMUNICATIONS SYSTEM. VA'S VOIP AND LAN SYSTEMS ARE NOT (C2015) LISTED FOR CRITICAL, EMERGENCY AND SAFETY FUNCTIONS AND SHALL NOT BE USED FOR SUCH UNTIL THEY OBTAIN LIFE SAFE CODE CERTIFIED STATUS)

- (a) Provide a complete and separate emergency UL-1069 OR general purpose UL- 2017 Listed and Labeled ICS with position ID (Note: the ICS may be a part of the EVNS), TIP (Re [Paragraph 7.2.3](#)) including TCO's and CCGS (Re [Paragraph 7.2.4](#)) systems. The ICS will perform emergency or, if approved, general purpose voice, aural and visual notification(s) to the SMS in the PCR and EMCR's SCC (and OSP's EMCC if not a part of the EMCR) and be controlled and operated by the Police Service.
- (b) At loading docks, provide an empty conduit system for connection of a telephone or VoIP non-emergency intercom.
- (c) In the Dental Clinic, provide a dedicated emergency IC system throughout the Dental area reporting to the Clinic's Administrative Desk. IC hands-free instruments may be substituted for a formal IC station as an acceptable alternate, if specifically approved by AHJ SMCS-005OP2H3.

CHAPTER 7: TELECOMMUNICATIONS SYSTEMS

- (d) In the Surgical Suite/Room, provide a dedicated “hands free” emergency IC system throughout the Surgical Area(s) reporting to the respective Lab(s) and Administrative Desk.
(**Note:** This requirement is in lieu of previously approved “hands free telephones” that are being phased out. At the direction of Region One Director, all future new and existing Facility VA Projects will remove all Critical Service Coded PBXs)
- (e) Provide appropriate IC systems at approved facility ingress and egress points connected directly to the PCR, ECC, EMCR (and OSP’s EMCC if not a part of the EMCR).
- (f) In the Pharmacy, provide a dedicated IC system throughout the Pharmacy area reporting to the administrative desk. Wireless IC may be substituted for a formal IC station as an acceptable alternate, if specifically approved by AHJ SMCS-005OP2H3.
- (g) ICS HE equipment will be located in the PCR, a dedicated room next to the PCR or the FMS portion of a TR closet to the PCR.
- (h) Connections to the FMS area of the MCR and TR must be approved by the AHJ during the Project Design and Technical Reviews at the beginning and throughout the project.
- (i) Wireless Add-On Systems must be compliant with [Paragraph 3.2.2](#) ; Wi-Fi Add-On Systems are not allowed.
- (j) Refer to CFM VA Master Specification 27 51 23 – Intercommunications and Program Systems for installation guidelines.

7.2.7.7 **EMERGENCY VOICE SWITCHING CONTROL (EVCS) – (Re: OI&T Design Guide, Voice Systems Minimum Operational Requirements)**

(**Note** - VA identified as an Emergency Communications System; and, VA’s VoIP AND LAN SYSTEMS ARE NOT (c2015) LISTED FOR CRITICAL, LIFE, AND EMERGENCY AND SAFETY FUNCTIONS AND SHALL NOT BE USED FOR SUCH UNTIL THEY OBTAIN LIFE SAFE CODE CERTIFIED STATUS)

- (a) Provide a complete and separate UL-2572 compliant EVCS (sometimes referred to as an Emergency Telephone System whose function is currently (c2015) performed by the Facility’s Telephone System’s Critical Coded Private Branch Exchange (PBX) that are being phased out (at the direction of OI&T of Region One’s Director for all future and existing facility projects) with position ID directly connected to and controlled by the SMS in the PCR and ECMR’s SCC and be controlled and operated by the Police Service, TIP (Re [Paragraph 7.2.3](#)) including TCO’s and CCGS (Re [Paragraph 7.2.4](#)) systems.
 - Provide a companion SSTV System if the EVCS does not have an integrated video component. The EVCS must operate, function and perform in conjunction with the SMS.

CHAPTER 7: TELECOMMUNICATIONS SYSTEMS

- EVCS HE equipment will be located in PCR, alternate dedicated room by the PCR or in the FMS portion of a TR closet to the PCR.
- Connections to the Facility's MCR and TR must be approved by the AHJ.
- The EVCS will control the EVNS where the two systems may be combined as approved by the AHJ during the Project Design and Technical Reviews at the beginning and throughout the project.
- Wireless Add-On Systems must be compliant with [Paragraph 3.2.2](#) ; Wi-Fi Add-On Systems are not allowed.
- Use these CFM's VA Master Construction Specifications for installation Guidelines:
 - i. 273100 - Voice Communications Switching and Routing Equipment.
 - ii. 273131 - Voice Communications Switching and Routing Equipment, Extension.

7.2.7.8 EMERGENCY (WITHIN BUILDING) DISTRIBUTED RF ANTENNA SYSGTEM (DAS) (Refer to Physical Security Design Manual for VA Facilities)

(NOTE - VA HAS IDENTIFIED DAS AS AN EMERGENCY/EMERGENCY RESPONDER COMMUNICATIONS SYSTEM)

- (a) Provide a complete and separate FCC Part 47 Listed, labeled AND VA/NTIA Licensed two way radio DAS with outside antenna(s) and antenna farm (Re [Paragraph 7.2.8.1](#)), internal antennas (aka Nodes) with supports, LPGS (Re [Paragraph 7.2.5](#)), TIP (Re [Paragraph 7.2.3](#)) including TCO's and CCGS (Re [Paragraph 7.2.4](#)) systems. See [Paragraph 3.3.1](#) for additional requirements.
- (b) The DAS shall conform to International Fire Code (IFC) Section 510 & Appendix J residing within NFPA 72.
- (c) The DAS will perform Emergency Two Way Voice Radio Communications for ONLY Emergency Responders that must enter and operate inside the Facility.
- (d) DAS HE equipment will be located in the Antenna HE Room (Re OI&T Design Guide) with remote control from the SMS in the PCR and EMCR's SCC (and OSP's EMCC if not a part of the EMCR) and be controlled and operated by the Police Service as approved by AHJ SMCS 005OP2H3 during the Project Design and Technical Reviews at the beginning and throughout the project.
- (e) Connections to the Facility's MCR and TR must be approved by the AHJ.
- (f) Wireless Add-On Systems must be compliant with [Paragraph 3.2.2](#) ; Wi-Fi Add-On Systems are not allowed.

CHAPTER 7: TELECOMMUNICATIONS SYSTEMS

- (g) Refer to CFM VA Master Specification 27 53 19 – Distributed Radio Antenna (within building) Equipment and System for installation guidelines.

7.2.7.9 **EMERGENCY SATELLITE RADIO-TELEPHONE SYSTEM (ESRS) (Refer to Physical Security Design Manual for VA Facilities)**

(NOTE - VA HAS IDENTIFIED ESRS AS AN EMERGENCY COMMUNICATIONS SYSTEM)

- (a) Provide a complete and separate FCC Part 47 Listed, labeled AND VA/NTIA Licensed two way radio ESRS with outside antenna(s) and antenna farm (Re [Paragraph 7.2.8.1](#)), internal antenna (aka Nodes) with supports, LPGS (Re [Paragraph 7.2.5](#)), TIP (Re [Paragraph 7.2.3](#)) including TCO's and CCGS (Re [Paragraph 7.2.4](#)) systems. The ESRS will provide basic and limited voice/telephone capability in the event internal and external Voice/VoIP/LAN/WAN systems failure. The ESRS must be able to make local, long distance, and international telephone calls directly over a satellite radio connection without using any land facilities.
- (b) ESRS HE equipment will be located in the Antenna HE Room (Re OI&T Design Guide) with remote control from the he SMS in the PCR and EMCR's SCC (and OSP's EMCC if not a part of the EMCR) and be controlled and operated by the Police Service or other location approved, by the AHJ, during the Project Design and Technical Reviews at the beginning and throughout the project.
- (c) Connections to the Facility's MCR and TR must be approved by the AHJ.
- (d) Wireless Add-On Systems must be compliant with [Paragraph 3.2.2](#); Wi-Fi Add-On Systems are not allowed
- (e) Contact AHJ SMCS 005OP2H3 for technical assistance in developing a specialized TPD or Technical Specification when an ESRS system is required by the facility; and, to apply for ESRS portable equipment and Antenna HE Room and Distribution System guidelines that may be required.

7.2.7.10 **Very Small Aperture Satellite Telecommunication (V-SAT) for Office of Emergency Management and Resilience (OSP)**

(NOTE - VA HAS IDENTIFIED THE OSP V-SAT AS AN EMERGENCY COMMUNICATIONS SYSTEM)

- (a) **(When Approved)** Provide a complete and separate FCC Part 47 Listed, Labeled and VA/NTIA Licensed OSP V-SAT System with outside antenna and antenna farm (Re [Paragraph 7.2.8.1](#)), LPGS (Re [Paragraph 7.2.5](#)), TIP (Re [Paragraph 7.2.3](#)) cabling including TCO's and CCGS (Re [Paragraph 7.2.4](#)) systems for reception of OSP off air and internal generated digital voice / audio and limited data satellite programming from the facility EMCR and OSP's EMCC's SCC.
- (b) The OSP V-SAT RF HE shall be located in the Antenna HE Room (Re OI&T Design Guide) with interconnecting conduits and cables provided.

CHAPTER 7: TELECOMMUNICATIONS SYSTEMS

- (c) The conduits provided shall be:
- One (1) empty 75mm [3 inch] conduit from the Antenna HE Room to the OSP V-Sat Antenna Location on the facility roof and terminate in a lockable raintight, wet listed enclosure.
 - i. The roof raintight, wet listed enclosure provided with PACS controlled from the SMS in the PCR and **OSP EMCC's** SCC that is primary operated and controlled by the **OSP EMCC's** SCC with secondary control and operating functions by the Facility Police Service SCC.
 - ii. Project documents shall provide direction to strengthen roof or specify antenna mounting hardware as approved by the OEM and AHJ.
 - One (1) 75mm [3 inch] inside diameter (ID) conduit from the EMOC's SCC to the associated OSP's EMCC's TR FMS Area; then to the secured FMS Area in the MCR; from the MCR to approved TCO location(s) in the Antenna HE Room.
 - Conduits from the MCR secured FMS Area to other TCOs approved by AHJ during the Project Design and Technical Reviews at the beginning and throughout the project.
- (d) The provided cables shall be:
- Coaxial, fiber and / or balanced TWP, from the OSP EMCC's SCC to the EMCC's TR secured FMS Area; then to the MCR's secured FMS Area.
 - Have 9 m [thirty (30) Linear Feet] of excess cable neatly coiled and secured to an approved mounting point for future cross-connecting and control equipment in the MCR secured FMS area. Cables shall be tagged to identify the area(s) each cable serves.
 - Matching cable(s) provided from the secured FMS Area of the MCR, to cross-connecting area in the Antenna HE Room that will connect to and control the Satellite Dish system operation on the Facility Roof (200 linear feet maximum); and RF system operation in the Antenna HE Room.
 - The Facility Police Service SCC with secondary control cables and conduits to the OSP's EMCC SCC via; the aforementioned paths.
 - Coaxial, fiber and / or balanced TWP cable, from the MCR secured FMS Area to other TCOs approved by AHJ during the Project Design and Technical Reviews at the beginning and throughout the project.
- (e) Wireless Add-On systems must be compliant with [Paragraph 3.2.2](#). Wi-Fi based add-on systems are not allowed.
- (f) Co-ordinate with the Facility's EMCR Operations Office and VACO's SMCS's AHJ for V-SAT Antenna, Receiving & Transmitting equipment, TCO connector and separate V-SAT System technical and requirements in developing a specialized TPD or Technical Specification when a OEMP V-

CHAPTER 7: TELECOMMUNICATIONS SYSTEMS

SAT system is required for the facility. Maintain these co-ordinations from the project beginning and through its conclusion and system certification.

7.2.8 PATIENT, STAFF AND PUBLIC SAFETY SYSTEMS

7.2.8.1 SECURITY SURVEILLANCE TELEVISION (SSTV) (Sometimes Referred to as Closed Circuit Television (CCTV))

(NOTE - VA IDENTIFIED AS A SAFETY COMMUNICATIONS SYSTEM WHEN USED BY POLICE AND LAW ENFORCEMENT SERVICE)

- (a)** Provide a complete and separate UL-1492 compliant SSTV with position ID, connected to the SMS in the PCR and EMCR's SCC (and OSP's EMCC if not a part of the EMCR) and be controlled and operated by the Police Service, TIP (Re [Paragraph 7.2.3](#)) including TCO's and CCGS (Re [Paragraph 7.2.4](#)) systems; and LPGS for all outside camera/system equipment.
- (b)** SSTV System HE equipment will be located in the PCR, a dedicated room by the PCR or the FMS area of a TR closet to the PCR.
- (c)** The SSTV System must operate, function and be controlled by the SMS. The SSTV System will perform Facility Police Safety and Emergency Visual observation in Facility designated locations within and its interior and exterior (i.e. Parking Lots, Entrances, etc.) as approved by AHJ SMCS 005OP2H3 during the Project Design and Technical Reviews at the beginning and throughout the project.
- (d)** SSTV components must conform to the respective NRTL (i.e. UL) listings for each item forming the whole SSTV System.
- (e)** Connections to the Facility's MCR and TR must be approved by the AHJ.
- (f)** Wireless Add-On Systems must be compliant with [Paragraph 3.2.2](#) ; Wi-Fi Add-On Systems are not allowed.
- (g)** Refer to CFM VA Master Specification 28 23 00 – Video Surveillance System for installation requirements.

7.2.8.2 MOTION INTRUSION DETECTOR (MID)

(NOTE - VA HAS IDENTIFIED A PATIENT, STAFF AND PUBLIC SAFETY COMMUNICATIONS SYSTEM WHEN USED BY POLICE AND LAW ENFORCEMENT SERVICE)

- (a)** Provide a complete and separate UL 681 & 639 compliant MID/IDS System with position ID, TIP (Re [Paragraph 7.2.3](#)) including TCO's and CCGS (Re [Paragraph 7.2.4](#)) systems, connected to the SMS in the PCR and EMCR's SCC (and OSP's EMCC if not a part of the EMCR) and be controlled and operated by the Police Service.
- (b)** MID HE equipment will be located in the PCR, a dedicated room by the PCR or the FMS area of a TR closet to the PCR.

CHAPTER 7: TELECOMMUNICATIONS SYSTEMS

- (c) The MID/IDS System must operate, function and be control by the SMS as approved by AHJ SMCS 005OP2H3 during the Project Design and Technical Reviews at the beginning and throughout the project.
- (d) Connections to the Facility's MCR and TR must be approved by the AHJ.
- (e) Wireless Add-On Systems must be compliant with [Paragraph 3.2.2](#) ; Wi-Fi Add-On Systems are not allowed.
- (f) Refer to VA Master Specification for installation guidelines (**Note** – both of these documents must be used to provide a formal MID):
 - 28 13 53 Security Access Detection.
 - 28 16 00 Intrusion Detection System.

7.2.8.3 SECURITY MANAGEMENT AND CONTROL, AND CENTRALIZED POLICE SECURITY MANAGEMENT (SMS)

(**NOTE** - VA HAS IDENTIFIED SMS AS A PATIENT, STAFF AND PUBLIC SAFETY COMMUNICATIONS SYSTEM WHEN USED BY POLICE AND LAW ENFORCEMENT SERVICE)

- (a) Provide a complete and separate UL-2050 and Certification Bulletin 2010-04 compliant SMS (sometimes referred to as a Security Management Telecommunications System (SMTS)) with position ID, TIP ([Re Paragraph 7.2.3](#)) including TCO's and CCGS ([Re Paragraph 7.2.4](#)) systems.
- (b) The SMS shall be installed in the PCR and EMCR's SCC (and OSP's EMCC if not a part of the EMCR) and be controlled and operated by the Police Service.
- (c) The SMS must monitor, operate, function with and control the: EVNS, ICS, TRS, EVCS, DAS, SSTV, MID/IDS, EADC; AND have alternate control and monitoring of the PAS, RPS, and other authorized systems approved by AHJ SMCS 005OP2H3 during the Project Design and Technical Reviews throughout the project.
- (d) SMS HE equipment will be located in PCR, alternate dedicated room by the PCR or in the FMS area of a TR closet to the PCR as approved by AHJ SMCS 005OP2H3.
- (e) Connections to the Facility's MCR and TR must be approved by the AHJ.
- (f) Wireless Add-On Systems must be compliant to Paragraph 3.3.2; Wi-Fi Add-On Systems are not allowed.
- (g) Refer to the following VA Master Specifications for installation requirements (**Note** - both of these documents must be used to form a formal SMS)
 - 28 13 00 – Physical Access Control System.
 - 28 13 16 – Physical Access Control System and Data Base Management.

CHAPTER 7: TELECOMMUNICATIONS SYSTEMS

7.2.8.4 ELECTRONIC ACCESS AND DOOR CONTROL (EADC) - (AKA PACS)

(NOTE - VA IDENTIFIED AS A PATIENT, STAFF AND PUBLIC SAFETY COMMUNICATIONS SYSTEM WHEN USED BY POLICE AND LAW ENFORCEMENT SERVICE)

- (a) Provide a complete and separate Federal Information Processing Standard (FIPS) 202-1 and National Institute of Standards and Technology (NIST) Personally Identifiable Information (PII) EADC System with position ID (sometimes referred to as Physical Access Control System (PACS)), TIP (Re Paragraph 7.2.3) including TCO's and CCGS (Re Paragraph 7.2.4) systems, connected to the SMS in the PCR and EMCR's SCC (and OSP's EMCC if not a part of the EMCR) and be controlled and operated by the Police Service. The EADC must function with current VA PACS and SMS equipment standard regardless where installed.
- (b) EADC HE equipment will be located in the PCR, a dedicated room by the PCR or the FMS area of a TR closet to the PCR; and, must be monitored, operated and control by the SMS.
- (c) PACS ID Cards (aka NIST PIV) must be of non-priority construction and function as approved by AHJ SMCS 005OP2H3 during the Project Design and Technical Reviews at the beginning and throughout the project.
- (d) Connections to the Facility's MCR and TR must be approved by the AHJ.
- (e) Wireless Add-On Systems must be compliant with Paragraph 3.2.2 ; Wi-Fi Add-On Systems are not allowed.
- (f) Refer to VA Master Specifications identified in Paragraph 7.2.8.3 (g) that must be used to provide a formal PACS.

7.2.8.5 PATIENT OR STAFF ANNUNCIATOR/LOCATOR (PAL) & PATIENT ANNUNCIATOR/LOCATOR (PAN) (NOTE – the PAN's system installation operation will be combined with, and become a part of the PAL)

(NOTE – VA IDENTIFIED AS A PATIENT AND/OR STAFF SAFETY SYSTEM)

- (a) Provide a complete and separate UL-2017 compliant PAL System with that contains the PAN, TIP (Re Paragraph 7.2.3) including TCO's and CCGS (Re Paragraph 7.2.4) systems and have location ID, connected to the PCR and EMCR's SCC (and OSP's EMCC if not a part of the EMCR) and be controlled and operated by the Police Service (add each associated Nurses Station when Patient functions are performed).
- (b) PAL/PAN HE equipment will be located in the PCR, a dedicated room by the PCR, or the FMS area of a TR closet to the PCR and must be monitored, operated and controlled by the SMS as approved by AHJ SMCS 005OP2H3 during the Project Design and technical reviews at the beginning and throughout the project.
- (c) Connections to the Facility's MCR and TR must be approved by the AHJ.

CHAPTER 7: TELECOMMUNICATIONS SYSTEMS

- (d) Wireless Add-On Systems must be compliant with [Paragraph 3.2.](#); Wi-Fi Add-On Systems are not allowed.
- (e) The PAL / PAN is not allowed to be connected to or become a part of the RFID System since the RFID is a non-coded compliant system and is not allowed to do safety of life, emergency or safety system.
- (f) Contact AHJ SMCS 005OP2H3 for technical assistance in developing a specialized TPD or Technical Specification when a PAL/PAN system is required by the facility; and, Antenna HE Room and Distribution System(s) that may be required.

7.2.9 OTHER SPECIAL COMMUNICATIONS SYSTEMS

7.2.9.1 MASTER ANTENNA TELEVISION (MATV)

(NOTE – VA DOES NOT HAVE A SPECIFIC CLASSIFICATION FOR THIS SYSTEM)

- (a) Provide Master Antenna Television (MATV) system(s) that are High Definition TV (HDTV) compliant, as required.
- (b) MATV system antennas shall be mounted outside on hinged poles (or equivalent) where subjected to salt-spray atmosphere.
- (c) Provide MATV connections to TCOs at ceiling or on the wall near patient beds. Verify type TV set (swing arm, ceiling, or wall-mounted) to be used. Provide additional MATV wall/ceiling outlets mounted at designated areas.
- (d) Provide a separate National Television Standards Committee (NTSC) compliant High Definition (HD) MATV (Broad-band) System with outside antenna(s) and antenna farm (Re [Paragraph 7.2.8.1](#)), LPGS (Re [Paragraph 7.2.5](#)), TIP (Re [Paragraph 7.2.3](#)) including TCO's and CCGS (Re [Paragraph 7.2.4](#)) systems.
- (e) The MATV (Broadband) System HE equipment will be installed in the Antenna HE Room (Re OI&T Design Guide) and be connected to, monitored, operated and controlled by the Office of Education (OED) and/or Medical Media Office (MMO) or as approved by AHJ SMCS 005OP3H3.
- (f) Provide MATV (Broadband) system cable(s) for reception and generated MATV (Broadband) programming from the OED (MMO) through the Antenna HE Room, to the FMS Area of each TR and terminated in TCOs in Facility location(s) approved by AHJ during the Project Design and Technical Reviews at the beginning and throughout the project. If required, provide MATV (Broadband) System and control cable(s) from the Antenna HE Room to the Facility DEMARC Room (Re OI&T Design Guide; OR, cross connect in the secured FMS area of the MCR) to the Service Provider Facility Communications Entrance Cables.
- (g) Connections to the Facility's MCR and TR must be approved by the AHJ.

CHAPTER 7: TELECOMMUNICATIONS SYSTEMS

- (h) Wireless Add-On systems must be compliant with [Paragraph 3.2.2](#). Wi-Fi based add-on systems are not allowed
- (i) Refer to CFM VA Master Specification 27 41 31 – Master Antenna Television Equipment and Systems for installation requirements.

7.2.9.2 TELEVISION RECEIVE ONLY MASTER ANTENNA SATELLITE TELEVISION (TVRO)

(NOTE – VA DOES NOT HAVE A SPECIFIC CLASSIFICATION FOR THIS SYSTEM)

- (a) **(WHEN APPROVED)** - provide a separate NTSC compliant HD TVRO (Broad-band) System with outside antenna(s) and antenna farm (Re [Paragraph 7.2.8.1](#)), LPGS (Re [Paragraph 7.2.5](#)), TIP (Re [Paragraph 7.2.3](#) Including TCO's and CCGS (Re [Paragraph 7.2.4](#)) systems.
- (b) HD TVRO (Broadband) System HE equipment will be installed in the Antenna HE Room (Re OI&T Design Guide) and be connected to, monitored, operated and controlled by the E&MMO or as approved by AHJ SMCS 005OP3H3.
- (c) Provide HD TVRO (Broadband) system cable(s) for reception and generated HD MATV (Broadband) programming from the E&MMO through the Antenna HE Room, to the FMS Area of each TR and terminated in TCOs in facility location(s) approved by AHJ during the Project Design and Technical Reviews at the beginning and throughout the project.
- (d) If required, provide HD TVRO (Broadband) System and control cable(s) from the Antenna HE Room to the Facility DEMARC Room (Re OI&T Design Guide; OR, cross connect in the secured FMS area of the MCR) to the Service Provider Facility Communications Entrance Cables.
- (e) Connections to the Facility's MCR must be approved by the AHJ.
- (f) Wireless Add-On systems must be compliant with [Paragraph 3.2.2](#) . Wi-Fi based add-on systems are not allowed.
- (g) Contact AHJ SMCS 005OP2H3 for design engineering, technical, installation and certification assistance in developing a specialized TPD or Technical Specification when a HD TVRO system is required by the facility.

7.2.9.3 RADIO ENTERTAINMENT DISTRIBUTION (RED)

(NOTE – VA DOES NOT HAVE A SPECIFIC CLASSIFICATION FOR THIS SYSTEM)

- (a) Provide a RED System with outside antenna and antenna farm (Re [Paragraph 7.2.8.1](#)), LPGS (Re [Paragraph 7.2.5](#)), TIP (Re [Paragraph 7.2.3](#)) cabling including TCO's and CCGS (Re [Paragraph 7.2.4](#)) systems.
- (b) The RED HE equipment will be installed in the Antenna HE Room (Re OI&T Design Guide, Page 4-76) and be connected to, monitored, operated and controlled by the E&MNO or as approved AHJ SMCS 005OP3H3

CHAPTER 7: TELECOMMUNICATIONS SYSTEMS

during the Project Design and Technical Reviews at the beginning and throughout the Project.

- (c) Provide RED system cable(s) for reception and generated RED programming from the E&MMO through the Antenna HE Room, to the FMS Area of each TR and terminate in TCOs in Facility location(s) approved by AHJ SMCS 005OP2H3.
- (d) Connections to the Facility's MCR and TR must be approved by the AHJ SMCS 005OP2H3.
- (e) Wireless Add-On systems must be compliant with [Paragraph 3.2.2](#) Wi-Fi based add-on systems are not allowed.
- (f) Contact AHJ SMCS 005OP2H3 for design, engineering, technical, installation and certification assistance in developing a specialized Technical Purchase Description (TPD) or Technical Specification when a RED system is required for the facility.

7.2.9.4 VIDEO TELECONFERENCING SYSTEM (VTS)

(NOTE – VA DOES NOT HAVE A SPECIFIC CLASSIFICATION FOR THIS SYSTEM)

- (a) **(WHEN APPROVED)** - provide a VTS with TIP (Re [Paragraph 7.2.3](#)) cabling including TCO's and CCGS (Re [Paragraph 7.2.4](#)) systems.
- (b) The VTS HE equipment will be installed in the Antenna HE Room (Re OI&T Design Guide) and be connected to, monitored, operated and controlled by the OED (MMPS) or as approved AHJ SMCS 005OP3H3 during the Project Design and Technical Reviews at the beginning and throughout the Project.
- (c) Provide VTS system cable(s) for reception and generated VTS programming from the OED (MMPS) through the Antenna HE Room, to the FMS Area of each TR and terminate in TCOs in Facility location(s) approved by AHJ SMCS 005OP2H3.
- (d) Connections to the Facility's MCR must be approved by the AHJ.
- (e) Wireless Add-On systems must be compliant with [Paragraph 3.2.2](#). Wi-Fi based add-on systems are not allowed.
- (f) Contact AHJ SMCS 005OP2H3 for design, engineering, technical, installation and certification assistance in developing a specialized TPD or Technical Specification when a VTS is required for the facility.

7.2.9.5 V-SAT (for Office of Education) (OED))

(NOTE – VA DOES NOT HAVE A SPECIFIC CLASSIFICATION FOR THIS SYSTEM)

- (a) **(WHEN APPROVED)** - VA has identified the OED (MMPS) V-SAT as an unsecure communications system.
- (b) Provide a complete and separate FCC Part 47 Listed, Labeled and VA/NTIA Licensed OED (MMPS) V-SAT System with outside antenna and antenna farm, LPGS (See [Paragraph 7.2.8.1](#)), TIP cabling including TCO's

CHAPTER 7: TELECOMMUNICATIONS SYSTEMS

(See [Paragraph 7.2.3](#)) and CCGS (See [Paragraph 7.2.4](#)) systems for reception of OED off air and internal generated digital voice / audio and limited data satellite programming from the facility OED (MMPS) CC or in Medical Media Production Service (MMPS).

- (c)** The OED (MMPS) V-SAT HE shall be located in the Antenna HE Room (Re OI&T Design Guide) with interconnecting conduits and cables provided.
- (d)** The provided conduits shall be:

 - One (1) 75mm [3 inch] inside diameter (ID) conduit from the MCR to the Antenna HE Room.
 - One (1) other empty 75mm [3 inch] empty conduit from the Antenna Head End Room to the V-Sat Antenna Location on the facility roof and terminate in a lockable raintight enclosure.
 - The roof raintight enclosure with PACS controlled from the SMS in the PCR and EMOR's SCC that is operated and controlled by the Police Service.
 - Conduits from the MCR secured FMS Area to other TCOs approved by AHJ during the Project Design and Technical Reviews at the beginning and throughout the project.
- (e)** Project documents shall provide direction to strengthen roof or specify antenna mounting hardware as approved by the AHJ.
- (f)** The provided cables shall be:

 - Associated OED (MMPS) local TR FMS Area, then to the secured FMS Area in the MCR, to approved TCO location(s) in the Antenna HE Room.
 - Coaxial, fiber and / or balanced TWP, from the OED (MMPS) CC to the OED (MMPS) TR secured FMS Area; then to the MCR's secured FMS Area.
 - Provide coaxial / fiber, balanced TWP and control cable(s) from the OED (or MMPS) CC to the local TR FMS area, then to the secured FMS area of the MCR, then to the Antenna HE room that will connect to and control the satellite dish and system operation on the facility room (200 linear feet maximum).
- (g)** Wireless Add-On systems must be compliant with [Paragraph 3.2.2](#) . Wi-Fi based add-on systems are not allowed.
- (h)** Co-ordinate with the Facility's OED (MMPS) Operations Office and VACO's SMCS's AHJ for V-SAT Antenna, Receiving & Transmitting equipment, TCO connector and separate V-SAT System technical and requirements in developing a specialized TPD or Technical Specification when a OEMP V-SAT system is required for the facility.

CHAPTER 7: TELECOMMUNICATIONS SYSTEMS

7.2.10 SPECIAL COMMUNICATIONS “SEPARATED” SYSTEMS

7.2.10.1 TELEVISION BROADCAST SATELLITE RADIO FREQUENCY FACILITY (TBSRF) (AKA EARTH or GROUND STATION)

(NOTE – VA DOES NOT HAVE A SPECIFIC CLASSIFICATION FOR THIS SYSTEM)

- (a) **(WHEN APPROVED)** Provide a complete and separate FCC Part 47 Listed, Labeled and VA/NTIA Licensed TBSRF System (aka Earth or Ground Station) with outside antenna and antenna farm LPGS (Re [Paragraph 7.2.8.1](#)), TIP cabling including TCO’s (Re [Paragraph 7.2.3](#)), and CCGS (Re [Paragraph 7.2.4](#)) systems for reception and transmission of OED off air and internal generated digital video, voice and audio and data satellite programming from the facility OED CC or in Medical Media Production Service (MMPS). Provide physical security (Re Paragraphs [7.2.8.3](#) [SMS] & [7.2.8.4](#) [PACS]).
- (b) The cables shall be routed to the:
- Outside Dish Antenna (see [Paragraph 7.2.5.1](#) Antenna Farm):
 - i. Contains extensive satellite tracking equipment,
 - ii. Provided with site protection.
 - iii. High Power transmitting equipment,
 - iv. Highly sensitive receiving equipment,
 - v. Complex multiplex terminal equipment,
 - Building large points of entry:
 - i. Air Dielectric RF Transmission Line
 - ii. Outside TIP interface.
 - iii. Operational, management, and control equipment.
 - iv. Outside Antenna waveguide.
- (c) Project documents shall provide direction for ground site prep and specify antenna mounting hardware as approved by AHJ SMCS 005OP2H3.
- (d) Cable and wire pathways (See [TIP 7.2.3](#)).
- (e) Fire protection (See [8.3.4](#)).
- (f) Power (Re [Paragraph 8.2](#) for additional requirements):
- UPS:
 - i. Provide local UPS in equipment racks or cabinets that will handle 100 percent (%) of the rack or cabinet installed equipment powered from the Critical Branch of the Essential Electrical System
 - ii. UPS with Battery Back-up or Reserve Battery Power Supply:
 - iii. Provide reserve battery power supply with capacity to supply system for a minimum of four (4) hours including projected maximum growth and interfaced equipment consisting of sealed

CHAPTER 7: TELECOMMUNICATIONS SYSTEMS

- (g)** Configuration: comply with PSDM, EDM & OI&T Design Guide,
- (h)** Location:
 - A dedicated room and large area is required.
 - Shall not be located:
 - i. Directly below or adjacent to laboratories, kitchens, laundries, fountains, toilets, showers, or other areas where water service is provided (i.e. facility entrance with water display(s), etc.).
 - ii. In the elevator equipment room, next to an electrical room, MCR, TR, MRI room, surgical - operating room, recovery room, medical recovery room and other treatment areas, in patient care areas, or below the Base Flood Elevation.
 - iii. Do not place radio equipment in the control or production rooms.
 - iv. In Administrative reception, break and toilet areas.
 - v. Comply with PSDM for other location requirements.
- (i)** Lightning – see [Paragraph 7.2.4](#)(LPGS).
- (j)** Grounding – see [Paragraph 7.2.3](#)(CCGS).
- (k)** Security – see [Paragraphs 7.2.8.3](#) (SMS) & [7.2.8.4](#) (EADC).
- (l)** Cable and Pathways – see [Paragraph 7.2.3](#) (TIP).

CHAPTER 7: TELECOMMUNICATIONS SYSTEMS

- (m) Cable Management:
 - ***DO NOT*** PROVIDE CABLES, WIRES AND TIP CONFIGURATION THAT WILL PRESENT ***ONE POINT OF FAILURE CONDITION***.
- (n) Wireless Add-On systems must be compliant with [Paragraph 3.2.2](#) . Wi-Fi based add-on systems are not allowed.
- (o) Co-ordinate with the Facility's OED (MMPS) Operations Office and VACO's SMCS's AHJ for TBRF Antenna, Receiving & Transmitting equipment, TCO connector and separate TBRF System technical and requirements in developing a specialized TPD or Technical Specification when a OED (MMPS) TBRF system is required for the facility.

7.2.10.2 TELEVISION PRODUCTION (AUDIO AND VIDEO) STUDIO FACILITY (TVSF)

(NOTE – VA DOES NOT HAVE A SPECIFIC CLASSIFICATION FOR THIS SYSTEM)

- (a) **(WHEN APPROVED)** - provide a separate National Association of Boasters (NAB), Society of Motion Picture and Television Engineers (SMPTE) and NTSC compliant HD TVSF, TIP (Re [Paragraph 7.2.3](#)) including TCO's and CCGS (Re [Paragraph 7.2.4](#)) systems. Provide physical security (Re [Paragraphs 7.2.8.3 \[SMS\]](#) & [7.2.8.4 \[EADC\]](#)).
- (b) The HD TVSF TVRF will be installed in the facility's E&MMO Area and be connected to, monitored, operated and controlled by the E&MMO or as approved by AHJ SMCS 005OP3H3.
- (c) Provide HD TVRF with inputs from the HD TVRO (Broadband) system, HD MATV (Broadband) System and programming from the OED (MMPS) through the Antenna HE Room, to the FMS Area of each TR and terminated in TCOs in Facility location(s) approved by AHJ during the Offer Design and Technical Reviews at the beginning and throughout the project.
- (d) Provide HD TVRO (Broadband) System and control cable(s) from the Antenna HE Room to the Facility OED (MMPS) (connected in the secured FMS area of the TR closest to the OED (MMPS)) to the Service Provider Facility Communications Entrance Cables.
- (e) Interface the TVSF with the TBRF to form a fully operational and functions television production and satellite transceiving system.
- (f) Provide the TVSF with the following minimum functions:
 - TV Production Studio.
 - Production Control Room(s).
 - Video processing and production room.
 - Audio processing and production room.
 - Video/Audio Editing and production Room.
 - Staging area(s).
 - Actor's dressing rooms.

CHAPTER 7: TELECOMMUNICATIONS SYSTEMS

- Reception room/area.
 - Break area with toilets.
- (g) Location:
- A dedicated room(s) and large area are required.
 - Shall *not* be located:
 - i. Directly below or adjacent to laboratories, kitchens, laundries, fountains, toilets, showers, or other areas where water service is provided (i.e. facility entrance with water display(s), etc.).
 - ii. In the elevator equipment room, next to an electrical room, MCR, TR, MRI room, surgical - operating room, recovery room, medical recovery room and other treatment areas, in patient care areas, or below the Base Flood Elevation.
 - iii. Comply with PSDM for other location requirements.
 - iv. Do not place radio equipment in the TVSF.
- (h) Power – see Paragraphs [7.2.10.2\(f\)](#) and [8.2](#).
- (i) Lightning – see [Paragraph 7.2.8\(LPGS\)](#) .
- (j) Grounding – see [Paragraph 7.2.7 \(CCGS\)](#).
- (k) Security – see [Paragraphs 7.2.8.3 \(SMS\)](#) & [7.2.8.4 \(PACS\)](#).
- (l) Cable and Pathways –see [Paragraph 7.2.3 \(TIP\)](#).
- (m) Cable Management:
- **DO NOT PROVIDE CABLES, WIRES AND TIP CONFIGURATION THAT WILL PRESENT A ONE POINT OF FAILURE CONDITION.**
- (n) Wireless Add-On Systems must be compliant with [Paragraph 3.2.2](#); Wi-Fi Add-On Systems are not allowed,
- (o) Co-ordinate with the Facility’s E&MM Operations Office and VACO’s SMCS’s AHJ for TVSF Audio Video Production Studio technical and installation requirements in developing a specialized TPD or Technical Specification when a TVSF is required for the facility.
- (p) Configurations: comply with National Association of Broadcasters (NAB - Engineering Handbook, EDM & OI&T Design Guide.

CHAPTER 7: TELECOMMUNICATIONS SYSTEMS

7.2.10.3 AUDITORIUM BASED PROFESSIONAL BASEBAND AUDIO AND VIDEO ORGINATION AND DISTRIBUTION SYSTEM (ABDS)

(NOTE – VA DOES NOT HAVE A SPECIFIC CLASSIFICATION FOR THIS SYSTEM)

- (a) **(WHEN APPROVED)** - provide an ABDS with TIP (Re Paragraph 7.2.3) cabling including TCO's and CCGS (Re Paragraph 7.2.4) systems. Provide physical security (Re Paragraphs 7.2.8.3 [SMS] & 7.2.8.4 [EADC]).
- (b) The ABDS System Control Console will be installed in the Auditorium's Equipment Room and routed to its associated TR and be connected to, monitored, operated and controlled by the EDO (MMPS); or, as approved by AHJ SMCS 005OP3H3 during the Project Design and Technical Reviews at the beginning and throughout the Project.
- (c) Provide ABDS system cable(s) for reception and generated audio and video programming from the EDO (MMPS) through the Antenna HE Room, to the FMS Area of the associated Auditorium TR and cross-connected the Auditorium's Control and Equipment Rooms and terminating in the ABDS Control Console and then routing to TCOs within the Auditorium location(s) approved by AHJ SMCS 005OP2H3. The ABDS shall contain, video processing and switching equipment, color cameras, audio microphones, mixers and speakers, video/computer accessed projecting equipment and ceiling/wall mounted projection screens and HD Video Monitors as approved by SMCS 005OP2H3. Provide Auditorium with:
- Control Room:
 - i. Cable pathways for installed equipment racks.
 - ii. Interconnecting conduits and pathways shown on drawings.
 - iii. Space and mounts for:
 - ENG type video camera, two (2) minimum.
 - Video / film projectors, two (2) minimum.
 - Clear line-of-sight viewing capability for entire Auditorium and stage.
 - Backbox for light control of Auditorium, Stage and Control Room.
 - Backbox for sound control of Auditorium, Stage and Control Room.
 - Backbox for video control of Auditorium, Stage and Control Room.
 - PA system speaker with volume control and interface for connecting to Auditorium sound system.
 - Backbox for intercom / que system to and from Stage.
 - Shall be divisible for multiple conference / class rooms.
 - Ceiling(s) that supports multiple video projectors and projector lifting equipment shall be provided with A/C power interface boxes and TCOs.
 - Wall backboxes containing connections for multiple interface panels and TCO's remoted to Control Room Backbox.
 - Equipment Room(s):

CHAPTER 7: TELECOMMUNICATIONS SYSTEMS

- i. One room to perform TR functions.
 - ii. One room to house all Control Room ancillary equipment, cabinets and racks.
 - iii. Additional room(s) as directed by AHJ during initial project design and throughout project.
 - iv. Four (4) TCO's in each location.
- Stage:
 - i. Front and each side step access.
 - ii. Ceiling suspended and electrical motor operated full length curtain.
 - iii. Backbox for intercom / que system to and from Control Room.
 - iv. Floor mounted interface panels and TCO's.
 - v. Wall Backboxes containing connections for multiple control panels and TCO's remoted to Control Room Backbox.
 - vi. Wall Backboxes containing connections for multiple interface panels and TCO's remoted to Control Room Backbox.
 - vii. Flat panel video displays.
 - viii. Speakers.
 - ix. Floor mounted Interface Panels and TCOs remoted to Control Room Backbox. Each Interface Panel shall contain:
 - One (1) TCO with: two TWP RJ-45 female connectors, one (1) HD TV F-male connector.
 - One (1) pair baseband video BNC (or equal) female connectors.
 - One pair of multi-mode fiber optic female connectors.
 - One pair of single-mode fiber optic female connectors.
 - One pair baseband audio XL (or equal) female connectors.
- (d) Connections to the Facility's MCR and TR must be approved by the AHJ.
- (e) Location :
 - A dedicated large area, with Control and adjoining Equipment Rooms, Stage and Anti-room Areas are required.
 - **Shall not be located:**
 - i. Directly below or adjacent to laboratories, kitchens, laundries, fountains, toilets, showers, or other areas where water service is provided (i.e. facility entrance with water display(s), etc.).
 - ii. In the elevator equipment room, next to an electrical room, MCR, TR, MRI room, surgical - operating room, recovery room, medical recovery room and other treatment areas, in patient care areas, or below the Base Flood Elevation.
 - iii. Comply with PSDM for other location requirements.
 - iv. Do not place radio transmitting equipment in the ABDS.

CHAPTER 7: TELECOMMUNICATIONS SYSTEMS

- (f) **Configuration: Comply with National Association of Broadcasters (NAB - Engineering Handbook & OI&T Design Guide).**
- (g) Power: comply with EDM (Re Paragraphs 7.2.10.1. (f) and 8.2 for additional requirements (hot link these).
- (h) Lightning: see Paragraph 7.2.8 (LPGS).
- (i) Grounding: see Paragraph 7.2.7 (CCGS).
- (j) Security: see Paragraphs 7.2.8.3 (SMS) & 7.2.8.4 (EADC).
- (k) Cable and Pathways see Paragraph 7.2.3 (TIP).
- (l) Wire Management:
DO NOT PROVIDE CABLES, WIRES AND TIP CONFIGURATION THAT WILL PRESENT **A ONE POINT OF FAILURE CONDITION**.
- (m) Wireless Add-On Systems must be compliant with Paragraph 3.2.2 ; Wi-Fi Add-On Systems are not allowed.
- (n) Contact AHJ SMCS 005OP2H3 for design, engineering, technical, installation and certification assistance in developing a specialized TPD or Technical Specification when an ABDS is required for the facility.

7.2.10.4 AUDIO AND VIDEO COMMUNICATION AND DISTRIBUTION SYSTEM (AVCD)

(NOTE – VA DOES NOT HAVE A SPECIFIC CLASSIFICATION FOR THIS SYSTEM, AND, MAY BE STAND-ALONE ROUTED FROM THE EDO (MMPS) OFFICE, OR, COMBINED WITH THE ABDS ROUTED AND CONTROLLED FROM THE CONTROL ROOM)

- (a) **(WHEN APPROVED)** - provide an AVCD with TIP (Re Paragraph 7.2.3) cabling including TCO's and CCGS (Re Paragraph 7.2.4) systems.
- (b) The AVCD System Control Console will be installed in the Auditorium's Control Equipment Room and routed to its associated Equipment / TRs and be connected to, monitored, operated and controlled by the EDO (MMPS); or, as approved by AHJ SMCS 005OP3H3 during the Project Design and Technical Reviews at the beginning and throughout the Project.
- (c) Provide AVCD system cable(s) for reception and generated audio and video programming from the EDO (MMPS), to the FMS Area of the associated Auditorium TR / Equipment Rooms and cross-connected the Auditorium's Control and Equipment Rooms and terminating in the AVCD Control Console approved by AHJ SMCS 005OP2H3.
- (d) The AVCD shall contain HD color and B&W, video, audio and film processing and switching equipment, ENG HD color video cameras and projectors, B&W/HD color film projectors, audio microphones, amplifiers, mixers and speakers, video, audio and film computer accessed processing

CHAPTER 7: TELECOMMUNICATIONS SYSTEMS

- and management equipment and ceiling/wall mounted projection screens and HD Video Flat Screen Monitors as approved by SMCS 005OP2H3.
- (e)** Connected to, interfaced with and managed by TVSF Control Room with ABDS equipment and systems; and, must operate and function with the Facility's current, or a future HDTV distribution system.
 - (f)** The AVCD shall contain:
 - Small Conference / Class Room(s):
 - i.** Small wall mounted flat screen with wall strengthened.
 - i.** VTS.
 - ii.** Computer interface(s).
 - iii.** TCO's.
 - iv.** AV Sound / video interface package.
 - v.** Wall back box for control panel.
 - vi.** Wall back box for interface panel.
 - vii.** Floor mounted back box conference table / lectern w/poke through.
 - viii.** Interconnecting conduit and pathways as shown on drawings.
 - Medium Conference / Class Rooms – fitted same as Small Room.
 - Large Conference Rooms – fitted same as Small Room, Except ADD:
 - i.** Ceiling video projector with ceiling strengthening.
 - ii.** Ceiling projection screen with ceiling strengthening.
 - iii.** Wall back box for inter-millwork mounted equipment rack.
 - iv.** Wall back box for video conferencing camera.
 - Waiting and Break Rooms, Staff Lounges.
 - i.** Structural backing or in ceiling structural support for video display.
 - ii.** Wall and ceiling strengthening as required.
 - Chapel – same as for Large Conference, Waiting and Break Rooms, Staff Lounges.
 - (g)** Configuration: comply with National Association of Broadcasters (NAB - Engineering Handbook & OI&T Design Guide.
 - (h)** Power – comply with EDM.
 - (i)** Lightning – see [Paragraph 8.5.2](#).
 - (j)** Grounding – see [Paragraph 8.5.3](#).
 - (k)** Security – see [Paragraph 8.5.4](#).
 - (l)** Cable and Pathways – see [Paragraph 8.5.5](#).
 - (m)** Wire Management - see – [Paragraph 8.5.5](#).

CHAPTER 7: TELECOMMUNICATIONS SYSTEMS

- (n) *Wireless Add-On Systems must be compliant with Paragraph 3.2.2; Wi-Fi Add-On Systems are not allowed.*
- (o) Contact AHJ SMCS 005OP2H3 for design, engineering, technical, installation and certification assistance in developing a specialized TPD or Technical Specification when an AVCD is required for the facility.

7.2.11 OI&T SYSTEMS REQUIRING AHJ SMCS 005OP2H3 CO-ORDINATION

7.2.11.1 V-SAT (for OI&T)

(NOTE – VA DOES NOT HAVE A SPECIFIC CLASSIFICATION FOR THIS SYSTEM)

- (a) (WHEN APPROVED) - VA has identified the OI&T V-SAT as an unsecure communications system.
- (b) Provide a complete and separate FCC Part 47 Listed, Labeled **and** VA/NTIA Licensed OI&T V-SAT System with outside antenna and antenna farm (Re Paragraph 7.2.8.1), LPGS (Re Paragraph 7.2.8), TIP (Re Paragraph 7.3.3) cabling including TCO's and CCGS (Re Paragraph 7.2.7) systems for reception of OI&T off air and internal generated digital voice / audio and limited data satellite programming from the facility OI&T DG either in an office area in the MCR.
- (c) The OI&T V-SAT System RF HE shall be located in the Antenna HE Room (Re OI&T Design Guide) provided with interconnecting conduits and cables.
- (d) The cables shall be routed from HE to the MCR and MCR's Data area approved TCO location(s).
- (e) Provide coaxial/fiber & balanced TWP cable, from other TCOs approved by AHJ during the Project Design and Technical Reviews at the beginning and throughout the project from to the local MCR Data area and shall be provided with 9.0 m [thirty (30) Linear Feet] of excess cable neatly coiled and secured to an approved mounting point for future cross-connecting and control equipment. Cables shall be tagged to identify the area(s) each cable serves.
- (f) Provide coaxial/fiber, balanced TWP and control cable(s) from the OI&T MCR CC to the MCR Data area, then to the Antenna HE Room that will connect to and control the Satellite Dish operation on the Facility Roof (61 m [200 linear feet] maximum).
- (g) The provided conduits shall be:
 - One (1) empty 75mm [3.0"] inside diameter (ID) conduit from the MCR to the Antenna HE Room.
 - One (1) empty 75mm [3.0"] conduit from the Antenna Head End Room to the V-Sat Antenna Location on the facility roof and terminate in a lockable raintight enclosure.

CHAPTER 7: TELECOMMUNICATIONS SYSTEMS

- Provide the empty roof raintight enclosure with PACS controlled from the SMS in the PCR and EMOR's SCC that is operated and controlled by the Police Service.
- (h) Project documents shall provide direction to strengthen roof or specify antenna mounting hardware as approved by the AHJ.
- (i) **Wireless Add-On systems must be compliant with Paragraph 3.2.2. Wi-Fi based add-on systems are not allowed.**
- (j) **Co-ordinate with the Facility's OI&T Operations Office and VACO's SMCS's AHJ for OI&T V-SAT Antenna, Receiving & Transmitting equipment, TCO connector and separate V-SAT System technical and requirements** in developing a specialized TPD or Technical Specification when an OI&T V-SAT system is required for the facility.

7.2.11.2 OI&T WIRELESS FIDELITY (WI-FI) SYSTEM

(NOTE – VA DOES NOT HAVE A SPECIFIC CLASSIFICATION FOR THIS SYSTEM)

- (a) **(WHEN APPROVED)** - contact VACO's OI&T Wi-Fi Project Manager to determine what Wi-Fi TIP (Re Paragraph 7.2.3) including TCO's, roof antenna(s) with antenna supports, internal antenna (aka Nodes) with supports, LPGS (Re Paragraph 7.2.8), CCGS (Re Paragraph 7.2.7) and Antenna Farm (Re Paragraph 7.2.8.1); plus, systems will be required that is approved by VACO's OI&T PM; AND, AHJ SMCS 005OP2H3 during the Project Design and Technical Reviews at the beginning and throughout the project. **The Facility or VACO OI&T Service will provide active Wi-Fi equipment to the project subcontractor for installation; OR, provide installation under a separate project. Contact the Facility OI&T Service for unique WI-FI needs that are not covered in the aforementioned requirements** (Note: WI-FI Systems are FCC Part 15 Unlicensed Equipment Listed and Labeled and **ARE NOT** to be used for Safety of Life OR DAS functions **OR** any Emergency/Safety service. Also, they are not NRTL (UL) or other regulatory standard(s) listed or labeled for operational emergency / safety parameters and functional limits.
- (b) **Wireless Add-on systems must conform to Paragraph 3.2.2. Approved Wi-Fi based add-on systems are the responsibility of the Facility OI&T Service.**

7.2.11.3 RADIO FREQUENCY IDENTIFICATION (RFID)

(NOTE – VA DOES NOT HAVE A SPECIFIC CLASSIFICATION FOR THIS SYSTEM)

- (a) Comply with VHA's RTLS MOU with AFGE (see note at the end of this paragraph) **BEFORE** the RFID system is provided in the project. Contact AHJ SMCS for a copy (Re Paragraph 1.3).
- (b) **(WHEN APPROVED)** - contact VACO's OI&T Wi-Fi Project Manager to determine what RFID TIP including TCO's, roof antenna(s) with antenna

CHAPTER 7: TELECOMMUNICATIONS SYSTEMS

supports, internal antenna (aka Nodes) with supports, LPGS (Re [Paragraph 7.2.8](#)), CCGS ([7.2.7](#)) and RF Antenna Farm (Re [Paragraph 7.2.8.1](#)) systems will be required that is approved by VACO's SMCS AHJ during the project Design and Technical Reviews at the beginning and throughout the project. **The Facility or VACO OI&T Service will provide active RFID System equipment to the subcontractor for installation; OR, provide installation under a separate project. Contact the Facility OI&T Service for unique RFID needs that are not covered in the aforementioned requirements ,**

(NOTE - SPECIFICALLY USING THE RFID SYSTEM FOR PATIENT OR STAFF LOCATION / MONITORING FUNCTIONS, VA HAS APPROVED UNIQUE TECHNICAL SPECIFICATIONS FOR THESE USES THAT MUST BE USED SINCE OHSA HAS VERY SPECIFIC REQUIREMENTS FOR PATIENT USES / CONNECTIONS AND VA'S UNION HAS VERY SPECIFIC REQUIREMENTS FOR STAFF LOCATION THAT MUST HAVE A SIGNED MOU BETWEEN VHA'S ASSISTANT DEPUTY SECRETARY, THE AFGE UNION AND THE FACILITY'S SENIOR STAFF BEFORE THE SYSTEM CAN BE CONSIDERED TO CONNECT TO THE PATIENTS OR MONITOR PATIENT / STAFF MOVEMENTS)

- (c) WI-FI Systems are FCC Part 15 Unlicensed Equipment Listed and Labeled and **ARE NOT** to be used for Safety of Life, DAS functions or Emergency / Safety service. Also, they are not NRTL (UL) or other regulatory standard listed or labeled for operational emergency / safety parameters and functional limits.
- (d) Wireless Add-on systems must conform to [Paragraph 3.2.2](#). Approved Wi-Fi based add-on systems **are the responsibility** of the Facility or VACO's OI&T Service.

7.2.12 SPECIAL MEDICAL COMMUNICATIONS SYSTEMS (SMCS)

- (a) **(WHEN APPROVED)** Provide a separate UL-2050 and Certification Bulletin 2010-04 compliant SMTS) interface with position ID, TIP (Re [Paragraph 7.2.3](#)) including TCO's and CCGS (Re [Paragraph 7.2.4](#)) (and LPGS [Re [Paragraph 7.2.5](#)], Antenna Farm [[7.2.8.1](#)] when necessary) systems, connected to the SMTS in the PCR and EMCR's SCC (and OSP's EMCC if not a part of the EMCR). The SMTS must monitor, operate, and function with the:
 - Behavioral Health Psychiatric-Grade Security Unit Door Control and Signaling System (see [Paragraphs 9.2.2](#) and [9.0](#)).
 - Behavioral Health Psychiatric Seclusion (aka Holding Room – see [Paragraphs 9.2](#) and [9.0](#)).
 - Narcotics Storage Control and Signal System (See [Paragraph 9.3](#)).
 - Elapsed Time Indicator (See [Paragraph 9.4.1](#)).
 - Systems as approved by AHJ SMCS 005OP2H3 during the Project Design and Technical Reviews throughout the project.

CHAPTER 7: TELECOMMUNICATIONS SYSTEMS

- (b)** Each Special Medical System and equipment must be located as approved by AHJ.
- (c)** Connections to the Facility's MCR must be approved by the AHJ.
- (d)** Refer to VA Master Specification 27 52 41 MISCELLANEOUS MEDICAL SYSTEMS for installation requirements.

CHAPTER 8: TABLE OF CONTENTS

CHAPTER 8: TABLE OF CONTENTS

FMS AND INFORMATION TECHNOLOGY ROOMS REQUIREMENTS

Note: Chapters 7 and 8 contain like references, guidelines and instructions that refer to each specific system/function. These "like" descriptions have been cross-referenced throughout both chapters to reduce redundancy. Additionally, each chapter contains acronyms that pertain to both; these have been combined in the beginning of Chapter 7.

8.0	GENERAL	8-5
8.1	ROOM TYPES AND DEFINITIONS.....	8-5
8.1.1	GENERAL	8-5
8.1.2	ANTENNA (RADIO) HEADEND EQUIPMENT ROOM	8-5
8.1.3	DEMARC ROOM	8-5
8.1.4	TELEPHONE OPERATORS ROOM (TOR) (IF USED).....	8-6
8.1.5	MAIN COMPUTER ROOM (MCR)	8-7
8.1.6	TELECOMMUNICATIONS ROOM (TR)	8-7
8.1.7	POLICE, ENGINEERING, AND EMERGENCY MANAGEMENT CONTROL ROOMS, AND OTHER DESIGNATED ROOMS.....	8-8
8.2	ELECTRICAL REQUIREMENTS	8-8
8.2.1	GENERAL	8-8
8.2.2	POWER	8-8
8.2.3	LIGHTING	8-9
8.2.4	SECURITY.....	8-9
8.2.5	CABLE AND WIRE PATHWAYS.....	8-10
8.3	ANTENNA HEADEND EQUIPMENT ROOM	8-10
8.3.1	GENERAL	8-10
8.3.2	LOCATION.....	8-10
8.3.3	CONFIGURATION	8-10
8.3.4	FIRE PROTECTION	8-11
8.3.5	GROUNDING	8-11
8.3.6	POWER	8-12
8.3.7	LIGHTING	8-12
8.3.8	SECURITY.....	8-12
8.3.9	WIRE MANAGEMENT.....	8-13
8.4	DEMARC ROOM	8-13
8.4.1	LOCATION.....	8-13
8.5	MAIN COMPUTER ROOM (MCR)	8-14
8.5.1	GENERAL	8-14
8.5.2	LOCATION.....	8-14
8.5.3	ELECTRICAL REQUIREMENTS	8-14
8.5.4	LIGHTNING	8-15
8.5.5	GROUNDING	8-15
8.5.6	SECURITY.....	8-15

CHAPTER 8: TABLE OF CONTENTS

8.5.7	CABLE MANAGEMENT.....	8-16
8.5.8	GROUNDING	8-16
8.5.9	ALTERNANTE MCR.....	8-16
8.6.9	MCR'S OPERATOR'S ROOM (MCOR)	8-16
8.5.10	GROUNDING	8-17
8.5.11	TELEPHONE EQUIPMENT (TER) AND TELEPHONE OPERATORS ROOMS (TOR) - (IF USED)	8-17
8.6	TELECOMMUNICATIONS ROOM (TR)	8-18

CHAPTER 8: FMS AND INFORMATION TECHNOLOGY ROOMS REQUIREMENTS

8.0 GENERAL

- (a) This chapter covers the electrical requirements for FMS and OI&T rooms and spaces in VA facilities.
- (b) These rooms may be co-occupied in existing facilities and shall be co-occupied in new construction by the FMS and OI&T Services.
- (c) Contact VA's AHJ SMCS 005OP2H3 for assistance with systems design, engineering, preparation of construction documents, installation, testing and VA certification.
- (d) Refer also to the EDM, PSDM and OI&T Design Guide.

8.1 ROOM TYPES AND DEFINITIONS

8.1.1 GENERAL

Provide rooms as determined by project requirements. Not all room types may be required and not all required room types may be listed below; and, Refer to the Office of Information and Technology Design Guide.

8.1.2 ANTENNA (RADIO) HEADEND EQUIPMENT ROOM

- (a) This room shall be a radio antenna headend (HE) room provided with RF functions and requirements that shall be included in a room completely separated from the DEMARC, MCR, TER (if used), TOR (if used), MCR and TRs to ensure that RF Power intrusion, electromagnetic (EMI) and radio frequency (RFI) interference / generation are not increased in these areas.
- (b) **UPS running time shall be minimum of 1.0 hour by individual rack / system equipment, comply with the OI&T Design Guide.**
- (c) EXCEPT FOR THE ANTENNA HEAD END ROOM, DO NOT PLACE RADIO (RF) EQUIPMENT INSIDE OF THE AFOREMENTIONED ROOMS AND ANY OTHER OF SIMILAR FUNCTION; AND, ONLY AS DIRECTED BY AHJ SMCS.
- (d) DO NOT PROVIDE RADIO EQUIPMENT INSIDE OF THE MCR, MCR, TER, TOR AND LIKE ROOMS.
- (e) Contact AHJ SMCS 005OP2H3 for design, engineering, technical, installation and certification assistance in developing a specialized TPD or Technical Specification when an Antenna Headend Equipment Room and/or Radio Antenna Farm is required for the facility.

8.1.3 DEMARC ROOM

- (a) The Demarc Room is a room designed to be the initial termination point in the building for outside service providers such as telephone companies, data providers, CATV providers, security providers, etc.
- (b) UPS running time shall be as stated in VA Physical Security Design Manual (PSDM).

CHAPTER 8: FMS AND INFORMATION TECHNOLOGY ROOMS REQUIREMENTS

- (c) DO NOT PLACE RADIO (RF) EQUIPMENT INSIDE OF THE DEMARC ROOM.
- (d) Contact AHJ SMCS 005OP2H3 for design, engineering, technical, installation and certification assistance in developing a specialized TPD or Technical Specification when a DEMARC Room is required for the facility.

8.1.4 TELEPHONE OPERATORS ROOM (TOR) (IF USED)

- (a) IF USED, The TOR is where telephone operators are located. Operators provide service to the entire building and/or facility. In most case, the TOR is continuously staffed. This function is being merged into the MCR (Refer to [Paragraph 8.1.5.1](#)).
- (b) At many facilities, the operators must also monitor critical FMS Alarms for required Nationally Coded FMS Life Safety, Critical, Emergency Equipment and Systems throughout the facility.
- (c) UPS running time shall be the same as the MCR or as stated in PSDM.
- (d) DO NOT PLACE RADIO EQUIPMENT INSIDE OF THE TOR.
- (e) Contact OI&T TVE **OR** AHJ SMCS 005OP2H3 for design, engineering, technical, installation and certification assistance in developing a specialized TPD or Technical Specification when a TOR is required for the facility ([Re Paragraph 1.3](#)).

8.1.4.1 TELEPHONE EQUIPMENT ROOM (TER) (IF USED)

- (a) IF USED **OR** AN EXISTING TER MUST BE RETAINED BY SYSTEM DESIGN) the TER shall be designed to house equipment that provides management of data and telephone (voice) trunk and phone services to the entire building or facility in addition to the MCR. The TER typically houses the Facility's Telephone Private Branch Exchange (PBX – AKA Telco Switch) that manages the facility's telephone (voice – NOT VoIP) trunks, equipment and services; PLUS, the required Facility's National Code FMS Life Safety, Critical, Emergency Equipment and Communications Systems. If retained, equip the TER the same as the MCR ([Re Paragraph 8.1.5](#)).
- (b) IF THE PBX IS BEING REMOVED – IMMEDIATELY CONTACT VA'S TVE Office (See [Paragraph 1.3](#)); AND, AHJ SMCS for LOW VOLTAGE FMS SPECIAL COMMUNICAITONS (SMCS 005oP2H3) FOR REQUIRED FACILITY ROOM AND TIP UPGRADES THAT WILL BE NECESSARY TO COMPENSATE FOR THE PBX'S REMOVAL BY ADDING EXTRA POWER, SPACE AND SUPPORT SYSTEMS AND EQUIPMENT.
- (c) UPS running time shall be the same as the MCR.
- (d) Do not place radio equipment inside of the TER.

CHAPTER 8: FMS AND INFORMATION TECHNOLOGY ROOMS REQUIREMENTS

- (e) Contact OI&T's TVE **OR** AHJ SMCS 005OP2H3 for design, engineering, technical, installation and certification assistance in developing a specialized TPD or Technical Specification when a TER is required for the facility ([Re Paragraph 1.3](#)).

8.1.5 MAIN COMPUTER ROOM (MCR)

- (a) The MCR shall be designed to house equipment that provides and manages data, LAN, WAN, and VoIP services to the entire building or facility. In addition to the MCR, there may be a Backup Computer Room that provides backup services in the event of a catastrophic failure at the MCR.
- (b) UPS running time shall be as stated in PSDM.
- (c) DO NOT PLACE RADIO EQUIPMENT INSIDE OF THE MCR.
- (d) Contact AHJ SMCS 005OP2H3 for design, engineering, technical, installation and certification assistance in developing a specialized TPD or Technical Specification when a MCR is required for the facility ([Re Paragraph 1.3](#)).

8.1.5.1 MAIN COMPUTER OPERATORS ROOM (MCOR)

- (a) The MCOR is where VoIP (AKA telephone voice) and data systems' operators are located. Operators provide service to the entire building or facility. In most case, the MCOR is continuously staffed.
- (b) At many facilities, the operators must also monitor critical FMS Alarms for required Nationally Coded FMS Emergency Equipment and Systems throughout the facility.
- (c) UPS running time shall be the same as the MCR.
- (d) **DO NOT PLACE RADIO EQUIPMENT INSIDE OF THE MCOR.**
- (e) Contact AHJ SMCS 005OP2H3 for design, engineering, technical, installation and certification assistance in developing a specialized TPD or Technical Specification when a MCR is required for the facility ([Re Paragraph 1.3](#)).

8.1.6 TELECOMMUNICATIONS ROOM (TR)

- (a) The TR is a room designed to centrally deliver VoIP, telephone (voice), data, and special systems services to users and equipment on that floor area. There may be multiple TR rooms on a floor. Where multiple TR rooms are employed, the TRs shall be associated with specific functional areas, as well as being vertically stacked from floor to floor.
- (b) The design term "TR" replaced the term "IDF". The designation indicates the current construction practice of combining telephone, data, special systems, and fire alarm functions into a single terminus, control, and

CHAPTER 8: FMS AND INFORMATION TECHNOLOGY ROOMS REQUIREMENTS

distribution point (Re [Paragraph 5.7](#) for additional requirements [hot link this]).

- (c) DO NOT PLACE RADIO EQUIPMENT INSIDE THE TR.
- (d) UPS running time shall be as stated in PSDM.

Contact AHJ SMCS 005OP2H3 for design, engineering, technical, installation and certification assistance in developing a specialized TPD or Technical Specification when a TR is required for the facility (Re [Paragraph 1.3](#)).

8.1.7 POLICE, ENGINEERING, AND EMERGENCY MANAGEMENT CONTROL ROOMS, AND OTHER DESIGNATED ROOMS

- (a) Other rooms that house specialized functions in the facility are Police Control Room (PCR), Engineering Control Center (ECC), EMCR'S SCC (and OSP EMCC if not a part of the EMCR), and other designated control rooms.
- (b) UPS running time shall be a minimum of 1.0 hour by equipment places in each equipment cabinet; or, as required by the PSTM.
- (c) DO NOT PLACE RADIO TRANSMITTING EQUIPMENT IN THESE ROOMS.
- (d) Contact AHJ SMCS 005OP2H3 for design, engineering, technical, installation and certification assistance in developing a specialized TPD or Technical Specification when any or all of the rooms are required for the facility (Re [Paragraph 1.3](#)).

8.2 ELECTRICAL REQUIREMENTS

8.2.1 GENERAL

The following is a list of minimum electrical requirement that apply to all voice (formerly Telephone PBX), VoIP and Data systems in the DEMARC, Antenna HE Room, MCR, MCOR, TER & TOR (if used), PCR and EMCR's SCC (and OSP's EMCC if not a part of the EMCR), TRs and those listed in Chapter 7 (Re [Paragraph 7.2.10.1\(f\)](#) for additional requirements), Special Communications Rooms and spaces (hereinafter referred to as "rooms" in this manual) that contain electronic FMS Special Communications and IT Equipment, whether under the authority of the Facility's FMS or OI&T Services.

8.2.2 POWER

Coordinate Power for all rooms with electrical engineer for 24 x 7 x 365 operation. Equipment shall be connected to the critical branch of the Essential Electrical System. Equipment (other than HVAC) shall be backed by an uninterruptible power supply (UPS) with running time as required in PSDM. Refer to EDM.

CHAPTER 8: FMS AND INFORMATION TECHNOLOGY ROOMS REQUIREMENTS

8.2.3 LIGHTING

- (a) Coordinate room lighting with lighting design professionals for rack, cabinets, ladder rack and other equipment locations.
- (b) Comply with the OI&T Design Guide.

8.2.4 SECURITY

Refer to Paragraphs 7.2.8 and 7.2.8.4 for additional requirements.

- (a) The minimum physical security requirements for rooms containing FMS and OI&T equipment and systems are: electronic Security Management System (SMS) with PACS functionally connected to the SMS in the PCR and EMCR's SCC (and OSP's EMCC if not a part of the EMCR).
- (b) Doors shall include a mechanical spring loaded "deadlocking feature" (not separate "deadbolt" lock), PACS associate electronic PIV card access device with keypad, electric strike and digital CCTV color camera routed to and directly controlled by the Facility's SMS in the PCR and EMCR's SCC (and OSP's EMCC if not a part of the EMCR).
- (c) Each room's security systems shall be powered from the Critical Branch of the Essential Electrical System
- (d) Provide minimum local 1.0 hour UPS in equipment racks or cabinets that will handle 100 percent (%) of the rack or cabinet installed equipment and, expansion; and, refer to the PSDM for additional UPS requirements.
 - Each UPS shall be monitored by the SMS in the PCR and EMCR's SCC (and OSP's EMCC if not a part of the EMCR) for power, alarms, and alarm history. Provide an additional connection to the ECC in the ECR for engineering alerts and trouble management.
 - UPS shall have dry contacts or external alarm and control from the SMS, and one "Form C" contact for local computer signaling.
 - The SMS UPS management function shall be provided with computer system shutdown software and hardware connectivity as required.
- (e) Each facility programmable door controller shall be fully functional in a standalone status if connection to the SMS is lost. Once the connection is restored, the local door control system shall update the SMS, located in PCR and EMCR's SCC (and OSP's EMCC if not a part of the EMCR), regarding all operations that occurred after the connection was interrupted. Then, the SMS shall update the local door control units to current operational function.
- (f) The PACS and SMS shall be fully compliant with VA's PII, PIV "Smart" ID Card and at a minimum, FIPS 201-1 and NRTL (i.e. UL) listed and labeled. New construction SMS shall be fully compatible and operate with PACS functions with the existing facility's SMS.

CHAPTER 8: FMS AND INFORMATION TECHNOLOGY ROOMS REQUIREMENTS

8.2.5 CABLE AND WIRE PATHWAYS

Refer to [Chapter 5](#) for TIP conduit and pathway requirements.

8.3 ANTENNA HEADEND EQUIPMENT ROOM

8.3.1 GENERAL

The Antenna Headend (HE) Equipment Room shall be located in the mechanical penthouse or other area dictated by system design and as close to the Antenna Farm as possible. The room shall accommodate all provided and planned FMS radio frequency based (RF) Special Systems and Headend Equipment Cabinets (i.e., DAS, MATV, CCTV, M/W, HF, V-SAT, TVRO, SSTV, RED, PA, Two-Way Radio, RPS, etc.). See [Paragraph 6.1.2](#) for typical FMS Special Systems information and technical requirements.

8.3.2 LOCATION

- (a) A dedicated room is required. This room shall be located in the mechanical penthouse (as close as possible to an outside antenna entrance) or attic, or an area as dictated by system design.
- (b) It shall be within 30.48 m [100 feet] of the outside antenna site (this length includes the height of the antenna mast or tower *and* the outside cable run to each. Immediately contact SMCS 005OP2H3 if these minimums need to be adjusted.
- (c) It shall not be located in the: elevator equipment room, in the basement, next to an electrical room, MCR, TR, MRI room, surgical room, in patient care areas, or below the Base Flood Elevation
- (d) Antenna HE Equipment room shall not be located further than 90 M [300 ft.] or less than 15 m [50 feet] from the nearest vertically-stacked TR.
- (e) Shall not be located directly below or adjacent to laboratories, kitchens, laundries, toilets, showers, or other areas where water service is provided.

8.3.3 CONFIGURATION

- (a) The room shall comply per the OI&T DG and Table 8-1. The room shall be designed to support RF headend equipment for a minimum of six (6) separate systems, four (4) future systems, overhead and wall wire management systems, weatherproof wall/ceiling cable feedthroughs, and conduits as identified in [Appendix B](#).
- (b) If located in the mechanical penthouse or attic *and* approved by SMCS-005OP2H3, separate the space from the rest of the area by floor-to-ceiling metal chain-link security fence with a minimum 1000 mm x 2100 mm [40 in x 84 in] locking pocket gate with PACS and CCTV managed by the SMS; OR provide environmental controlled locking equipment cabinets for each RF system with like security installed.

Table 8-1 Antenna Headend Equipment Room Minimum Size

CHAPTER 8: FMS AND INFORMATION TECHNOLOGY ROOMS REQUIREMENTS

NUMBER OF EQUIPMENT CABINETS/RACKS	ROOM SIZE SQ FT [M ²]
4 minimum	300 [27.9]
Add 2 UPS	300 [27.9]
Add 1 for System Grounding Block/Main TIP Distribution Panel (MTDP)	300 [27.9]
5 minimum	300 [27.9]
Add 2 for UPS	300 [27.9]
Add 1 for System Grounding Block/MTDP	300 [27.9]

- If cabinets are installed joined (or side by side), the 3 ft. [900 mm] clearance rule shall apply around the entire assembly.
- The room may use Environmental Equipment Protection Cabinets in lieu of air conditioned space, if previously approved by the Facility Engineer, RE and SMCS-005OP2H3. Add 1 sq. M [three (3) square feet] per each environmental cabinet with the 1 m [three (3) feet] additional clear floor area.

8.3.4 FIRE PROTECTION

Refer to the VA Fire Protection Design Manual.

8.3.5 GROUNDING

- (a) Interior - Provide a CCGS (Re [Paragraph 7.2.4](#) for additional requirements) copper bus plate minimum 150 mm x 450 mm x 13 mm [6 inch x 18 inch x 0.5 inch], with a connection point located on a room inside wall at least 9 m [30 LF] away from the antenna coaxial cable(s) entrance conduit sleeves.
- Connect this plate to the CCGS with a minimum #1/0 AWG stranded copper wire, or increased sized connection device (i.e., strap, buss, etc.) as approved by the RE and AHJ SMCS, to maintain the integrity of the CCGS (Refer to Paragraph 4.0 and Appendix A, for additional CCGS requirements).
 - Ensure the CCGS is directly connected to the building Intersystem Bonding Termination (IBT) at the grounding electrode conductor connection. Immediately notify the RE AND SMCS 005OP2H3 if there is a problem with or finding this connection.
- (b) Exterior - provide a LPGS (Re [Paragraph 7.3.5](#) for additional requirements) copper bus plate minimum 75 mm x 450 mm x 13 mm [3 in x 18 in x 0.5 in], with a connection point located on the room inside wall within .6 m [2.0 feet] of the immediate area of the antenna coaxial cable(s) entrance wall sleeves.

CHAPTER 8: FMS AND INFORMATION TECHNOLOGY ROOMS REQUIREMENTS

- Connect this plate *ONLY* to the external LPGS with a minimum #1/0 AWG stranded copper wire, or increased sized connection device (i.e., strap, buss, bar, etc.) as approved by the RE, to maintain the integrity of the LPGS.
- Connect all antenna farm equipment (i.e. antennas, cable sleeves, mounts, towers, poles, conduits, junction boxes, etc.) to the LPGS with a minimum #1/0 AWG stranded copper wire, or increased sized connection devices as approved by the RE, to maintain the integrity of the LPGS.
- Route the antenna farm LPGS in the most direct path to a certified earth ground and grounding equipment via a minimum #1/0 AWG stranded copper wire, or increased sized connection devices as approved by the RE, to maintain the integrity of the LPGS and earth ground connections.

8.3.6 POWER

(a) A/C

- Contact an Electrical Engineer and refer to [Paragraph 8.2.2](#).
- **At a minimum calculate actual required power by: $I = 1000 \times \text{kilowatts} \div (\text{PF}) \times \text{Volts}$**
- Comply with the EDM.

(b) UPS (See [Paragraph 5.6](#))

- Provide local 1.0 hour UPS in equipment racks or cabinets that will handle 100 percent (%) of the rack or cabinet installed equipment powered from the Critical Branch of the Essential Electrical System.
- Refer to the PSDM for additional UPS requirements.

8.3.7 LIGHTING

Refer to [Paragraph 8.2.3](#).

8.3.8 SECURITY

(Refer to [Paragraphs 8.2.4](#), [7.2.8.3](#) and [7.2.8.4](#))

- (a) Provide telephone (voice) instrument with connection to the facility's Emergency Voice Switching (or PBX if used) system; and, provide separate direct "ring down" to the SCC in the PCR and EMCR's SCC (and OSP's EMCC if not a part of the EMCR).
- (b) Provide Duress Alarm, door entry, antenna cable entry, equipment racks and power feed locations

CHAPTER 8: FMS AND INFORMATION TECHNOLOGY ROOMS REQUIREMENTS

8.3.9 WIRE MANAGEMENT

(Refer to refer to Paragraphs [8.2.5](#) & [7.2.3](#)).

- (a) Provide sleeves and conduit for initial and anticipated TIP access to the Antenna HE Room.
- (b) Do not provide “one point of TIP failure” in the room design.

8.4 DEMARC Room

- (a) All requirements of SECTION 8.3, GENERAL ENVIRONMENTAL, POWER AND SPACE REQUIREMENTS, apply to the DEMARC Room.
- (b) Comply with the OI&T Design Guide.
- (c) Size UPS run time as described in the PSDM.

8.4.1 LOCATION

- (a) A dedicated room is required OR, may be located in the MCR when approved by TVE and SMCS 005OP2H3.
- (b) **Shall *not* be located:**
 - Directly below or adjacent to laboratories, kitchens, laundries, toilets, showers, or other areas where water service is provided (i.e. facility entrance with water display(s), etc.).
 - In the elevator equipment room, next to an electrical room, MCR, TR, MRI room, surgical - operating room, recovery room, medical recovery room and other treatment areas, in patient care areas, or below the Base Flood Elevation.
 - Comply with PSDM for other location requirements.
 - Do not place radio (RF) equipment in the DEMARC Room.
- (c) Lighting
Refer to [Paragraph 8.2.3](#).
- (d) Security
Refer to [Paragraphs 8.2.4](#), [7.2.8.3](#) and [7.2.8.4](#).
- (e) Fire Protection
Refer to [Paragraph 8.3.4](#).
- (f) Configuration – comply with the OI&T Design Guide and PSDM.
- (g) Wire Management – Refer to [Paragraphs 8.2.5](#) and [7.2.2](#).
 - Provide sleeves and conduit for initial and anticipated TIP access to the DEMARC.
 - Do not place radio (RF) equipment in this room.
- (h) **Ground**
Refer to Paragraphs [8.3.5](#) and [7.2.4](#).

CHAPTER 8: FMS AND INFORMATION TECHNOLOGY ROOMS REQUIREMENTS

8.5 MAIN COMPUTER ROOM (MCR)

8.5.1 GENERAL

Assumes the functions of the TER, if that area / function is not a part of the project.

8.5.2 LOCATION

- (a) A large partitioned dedicated area; or, several rooms are required.
- (b) MCR and MCR shall be located next, or very close to each other.
- (c) Comply with PSDM and OI&T DG for other location requirements.
- (d) Close proximity to A/C Power, HVAC source and direct TIP inside and outside access.
- (e) With UPS (battery backup) load bearing floor and ventilation access.
- (f) **Shall not be located:**
 - Directly below or adjacent to laboratories, kitchens, laundries, fountains, toilets, showers, or other areas where water service is provided (i.e. facility entrance with water display(s), etc.).
 - In the elevator equipment room, next to an electrical room, MCR, TR, MRI room, surgical - operating room, recovery room, medical recovery room and other treatment areas, in patient care areas, or below the Base Flood Elevation.
 - Do not place radio (RF) equipment in the MCR.
 - On an outside wall.
 - In a room with windows.

8.5.3 ELECTRICAL REQUIREMENTS

- (a) The room shall be served by dedicated electrical panel(s) capable of providing 208/120V three phase, four wire or 277/480V power as required by the UPS equipment, HVAC equipment, and other equipment.
- (b) Electrical power shall be on critical branch of the Essential Electrical System. Each panel shall contain 20% spare electrical capacity and spare circuit breaker space.
- (c) UPS must provide running time as required in the PSDM.
- (d) UPS shall be sized based on the equipment requirements, plus future anticipated growth. The initial design load shall not be less than 30%, and not more than 70% of the UPS capacity.
- (e) UPS shall be monitored by the PCR SMS for power, alarms, and alarm history. UPS shall have dry contacts or external alarm and control from the PCR SMS and one "Form C" contact for local computer signaling. UPS shall be provided with computer system shutdown software and hardware connectivity as required.

CHAPTER 8: FMS AND INFORMATION TECHNOLOGY ROOMS REQUIREMENTS

- (f) Each workstation shall be provided with one (1) UPS-backed duplex receptacle and two (2) duplex normal power receptacles for desk lamps, fans, pencil sharpeners, etc.
- (g) Emergency Power Off (EPO) push buttons shall be installed at each egress door according to NFPA 75.
- (h) Provide a minimum of one (1) quadruplex receptacle (two duplex) for each 2.4 linear M [8 linear ft.] of wall space.
- (i) See Paragraphs [8.2.2](#) and [8.3.6](#) for additional power requirements.
- (j) Refer to [Appendix B](#) for more information and comply with the OI&T Design Guide for more information on system topology and area layouts within the MCR.

8.5.4 LIGHTNING

- (a) Refer to [Chapter 8.2.3](#) and comply with OI&T Design Guide.
- (b) Provide battery-powered lighting in accordance with NFPA 75.

8.5.5 GROUNDING

Refer to [Appendix A](#)

- (a) Refer to Paragraphs [8.3.5](#) and [7.2.4](#). The CCGS TMGB shall be directly connected to the facility's Intersystem Bonding Termination (IBT) at electrical grounding electrode conductor termination via a separate mechanically and electrically protected minimum #1/0 AWG stranded copper equipotential grounding conductor.
- (b) An AC electrical equipment grounding conductor is not acceptable for this function and shall not be approved.

8.5.6 SECURITY

- (a) Refer to Paragraphs [8.2.4](#), [7.2.8.3](#) and [7.2.8.4](#).
- (b) Each door shall have a color security surveillance camera that connects to a color monitor in OI&T Chief's Office, routed and control by the SMS in the PCR and EMCR's SCC (also the OSP's EMCC if not a part of the EMCR).
- (c) A Motion Intrusion Detection (MID) system shall be installed within the MCR. The system shall be controlled by the SMS in the PCR and EMCR's SCCs (also the OSP's EMCC if not a part of the EMCR).
- (d) Duress alarm button shall be placed every 3 m [10 linear ft.] within the MCR, annunciating to the SMS in the PCR and EMCR's SCCs, (also the OSP's EMCC if not a part of the EMCR) and to the MCOR (or TOR if used) Room and one (1) additional continuously 25/7/365-manned location.
- (e) Do not place radio (RF) equipment in the MCR.

CHAPTER 8: FMS AND INFORMATION TECHNOLOGY ROOMS REQUIREMENTS

8.5.7 CABLE MANAGEMENT

- (a) Refer to Paragraphs [8.2.5](#) and [7.2.2](#).
- (b) Provide sleeves and conduit for initial and anticipated TIP access to the MCR.
- (c) ***Do not*** design or allow one point of TIP failure in this area.
- (d) Provide two levels of cable tray below the ceiling. The upper tray shall contain fiber optic and copper backbone cabling. The lower tray shall contain cabling that connects equipment within the MCR (Refer to [Appendix A](#) and the OI&T Design Guide).
- (e) No information technology cabling shall be routed below the access flooring unless specifically approved by TVE, OI&T and AHJ SMCS.
- (f) Coordinate the cable tray size and location with the rack, cabinet, and hot aisle containment duct layout of the MCR.

8.5.8 GROUNDING

Refer to Paragraphs [8.2.5](#) and [7.2.4](#) and [Appendix A](#).

8.5.9 ALTERNANTE MCR

(IF APPROVED) - shall be provided the same as the MCR and comply with the OI&T Design Guide.

8.6.9 MCR'S OPERATOR'S ROOM (MCOR)

- (a) General - assumes the functions of the TOR, if that area is not a part of the project.
- (b) A dedicated room is required.
 - Room electrical and mechanical envelopes are the same as the MCR with the exception of the EPO.
 - Comply with the OI&T Design Guide.
- (c) Lighting – refer to [Paragraph 8.2.3](#).
- (d) Security – refer to Paragraphs [8.2.4](#), [7.2.8.3](#) and [7.2.8.4](#).
- (e) Fire Protection – refer to [Paragraph 8.3.4](#).
- (f) Configuration – comply with the OI&T Design Guide and PSDM.
- (g) Cable Management – Refer to [Paragraph 7.2.3](#).
 - Provide sleeves and conduit for initial and anticipated TIP access to the MCOR.
 - ***Do not design or allow a one point of TIP failure in this area.***
- (h) **Location**
 - MCR and TOR shall be located next, or very close to each other.
 - Comply with each location restriction of the MCR.

CHAPTER 8: FMS AND INFORMATION TECHNOLOGY ROOMS REQUIREMENTS

8.5.10 GROUNDING

Refer to Paragraphs [8.3.5](#) and [7.2.4](#) and [Appendix A](#) for additional requirements.

8.5.11 TELEPHONE EQUIPMENT (TER) AND TELEPHONE OPERATORS ROOMS (TOR) - (IF USED)

- (a) The TER spaces and functions are being phased into the MCR spaces; and, the functions of the TOR are being merged into the MCOR for all new construction projects regardless if generated from VACO or the Facility. Comply with the OI&T DG for the requirements of these consolidations.
- (b) If the project is to retain OR there is an existing TER and TOR that is officially designated that must remain; immediately contact TVE (see [Paragraph 1.3](#)) for specific project design, engineering, technical specifications, installation and testing documents and for VA certification assistance; AND, if for some reason, the TVE contact cannot be reached – contact AHJ SMCS (Re [Paragraph 1.3](#)).
 - IF THE PBX ***IS NOT*** TO BE RETAINED – ***IMMEDIATELY*** CONTACT TVE AND AHJ SMCS (Re [Paragraph 1.3](#)) FOR ***ADDITIONAL AND REQUIRED*** FMS CIRCUITS, EQUIPMENT AND SPACES ***THAT MUST BE PROVIDED*** TO COMPENSATE THE FACILITY'S EMERGENCY COMMUNICATIONS MANAGEMENT FUNCTIONS ***THAT WILL NO LONGER BE PROVIDED BY THE PBX.***
 - Radio Equipment – DO NOT install Facility Radios OR OTHER RF transmitting equipment in the TER or TOR.
- (c) **Configuration**
 - A large dedicated room or rooms are required.
 - All Room functional envelopes are to be the same as the MCR and/or MCOR.
 - Comply with [Appendix B](#), OI&T DG, EDM, PSDM ***AND*** CFM Master Construction Specifications:
 - i. 27 31 00 - Voice Communications Switching and Routing Equipment, *or*
 - ii. 27 31 31 - Voice Communications Switching and Routing Equipment Extension.
- (d) **Lighting** – refer to [Paragraph 8.2.3](#).
- (e) **Security** – refer to Paragraph, [8.2.4](#), [7.2.8.3](#) and [7.2.8.4](#).
- (f) **Fire Protection** – refer to [Paragraph 8.3.4](#).
- (g) **Cable Management** – Refer to Paragraphs [8.2.5](#) and [7.2.3](#).
 - Provide sleeves and conduit for initial and anticipated TIP access to the TER & TOR.
 - Do not design or allow a single point of TIP failure in this area.

CHAPTER 8: FMS AND INFORMATION TECHNOLOGY ROOMS REQUIREMENTS

(h) Location:

- A dedicated room is typically required (confirm with AHJ).
- Comply with the OI&T DG and PSDM.
- MCR and MCR shall be located next, or very close to each other.
- Close proximity to A/C Power, HVAC source and direct TIP inside and outside access.
- With UPS (battery backup) load bearing floor and ventilation access.
- **Shall not** be located:
 - i. Directly below or adjacent to laboratories, kitchens, laundries, fountains, toilets, showers, or other areas where water service is provided (i.e. facility entrance with water display(s), etc.).
 - ii. In the elevator equipment room, next to an electrical room, MCR, TR, MRI room, surgical - operating room, recovery room, medical recovery room and other treatment areas, in patient care areas, or below the Base Flood Elevation.
 - iii. Where any type(s) of compressed air, medical, cooling, exhaust gases or piping conveying these substances appears anywhere within the TER or TOR areas, in walls, ceilings and floors.
 - iv. On an outside wall; in a room with no windows.

(i) Grounding – see Paragraphs 8.3.5 and 7.2.7.

8.6 TELECOMMUNICATIONS ROOM (TR)

Refer to [Paragraph 5.7](#)

The TR Room shall be located in the center core of the facility and vertically stacked when another TR is used on the next floor(s) or other area dictated by system design. The room shall accommodate all provided and planned FMS based special systems local area headend equipment floor or wall cabinets (i.e., UPS, DAS, MATV, CCTV, VTE, TVRO, SSTV, NC & Code Blue, RED, PA, IC, PACS, etc.). See CHAPTER 7 for typical FMS Special Systems information and technical requirements.

(a) Power

- See Paragraphs 8.3.6 and 7.2.10.1. (f).
- The room shall be served by a minimum dedicated 100A, 120/208V, 3-phase, 4-wire panelboard; plus, as required under NFPA 75.
- Electrical power shall be on critical branch of the Essential Electrical System.
- Sizes of branch circuits serving power to racks may vary in order to meet additional load from VoIP devices (i.e. telephones, cameras, etc.). This practice is in place because PBX that normally powers phone system may not be included in the project.
- In addition to the circuits required to power the OI&T and FMS equipment and/or UPS equipment, provide wall mounted dedicated 120V 20A circuit with:

CHAPTER 8: FMS AND INFORMATION TECHNOLOGY ROOMS REQUIREMENTS

- i. Four (4) duplex receptacles centered in each of the room's side backboard,
 - ii. Four (4) duplex receptacles centered in each of the room's front backboard,
 - iii. Two (2) duplex receptacle on either side of the room door,
 - iv. Six (6) duplex receptacles centered in the room's rear backboard.
 - v. All receptacles shall be 450 mm [18 in] above finished floor (AFF).
 - vi. Allow on more than six (6) duplex receptacles on each 20A circuit.
- Provide UPS run time as described in the PSDM powered from the Critical Branch of the Essential Electrical System.

(b) Lighting

Refer to [Paragraph 8.2.3](#).

(c) Grounding

Refer to Paragraphs [8.3.5](#), [7.2.4](#) and [Appendix A](#).

(d) Security

Refer to Paragraphs [8.2.4](#), [7.2.8.3](#) and [7.2.8.4](#).

(e) Cable Management

- Each room shall be provided with lateral and vertical risers from the MCR to each room to support the TIP distribution system for telephone (voice), data, and FMS special systems.
- Each room shall be provided with two levels of cable tray. The upper level of tray shall contain backbone cables. The lower level of tray shall contain horizontal distribution cables, and shall connect to the floor distribution tray (Refer to [Appendix A](#)).
- Refer to Paragraphs [8.5.5](#) and [7.2.3](#) for additional requirements.

(f) Radio Equipment

DO NOT install Facility Radios OR OTHER RF transmitting equipment in the TR or other like room or area.

(g) Location

- **Shall *not* be located:**
 - i. Directly below or adjacent to laboratories, kitchens, fountains, laundries, toilets, showers, or other areas where water service is provided (i.e. facility entrance with water display(s), etc.).
 - ii. In the elevator equipment room, next to an electrical room, MCR, TR, MRI room, surgical - operating room, recovery room, medical recovery room and other treatment areas, in patient care areas, or below the Base Flood Elevation.

CHAPTER 8: FMS AND INFORMATION TECHNOLOGY ROOMS REQUIREMENTS

- iii.** Where any type(s) of compressed air, medical, cooling, exhaust gases or piping conveying these substances appears anywhere within the TER or TOR areas, in walls, ceilings and floors.
- iv.** On an outside wall;
- v.** In a room with windows.

CHAPTER 9: TABLE OF CONTENT

CHAPTER 9: TABLE OF CONTENTS

9.0	GENERAL	9-1
9.1	PATIENT WALL SYSTEMS.....	9-1
9.1.1	PREFABRICATED BEDSIDE PATIENT UNIT (PBPU)	9-1
9.1.2	SPECIALIZED TECHNICAL ASSISTANCE.....	9-1
9.2	BEHAVIORAL HEALTH (AKA PSYCHIATRIC OR MENTAL HEALTH) AREA.....	9-1
9.2.1	ROOMS	9-1
9.2.2	AREA DOOR CONTROL AND SIGNAL SYSTEM	9-2
9.2.3	SPECIALIZED TECHNICAL ASSISTANCE.....	9-3
9.3	NARCOTICS STORAGE ALERTING AND SIGNAL SYSTEM (NSAS)	9-3
9.3.1	SPECIALIZED TECHNICAL ASSISTANCE.....	9-4
9.4	SPECIALIZED MEDICAL TIME KEEPING DEVICES.....	9-4
9.4.1	MEDICAL ELAPSED TIME INDICATOR (METI)	9-4
9.4.2	MEDICAL SYNCHRONIZED CLOCK SYSTEM (MSCS).....	9-5

CHAPTER 9: TABLE OF CONTENT

This page intentionally left blank.

CHAPTER 9: SPECIAL MEDICAL AND ALARM SYSTEMS

9.0 GENERAL

VA uses nonflammable anesthetics in Operating and Surgical Rooms; plus Medical Research Services. Installations in these areas shall conform to the portions of NFPA 99 that pertain to nonflammable anesthetics.

9.1 PATIENT WALL SYSTEMS

In certain intermediate and critical care areas, VA requires the installation of patient wall systems, sometimes referred to as Prefabricated Bedside Patient Unit (PBPU) in patient bedrooms/areas. The PBPUs shall be installed as described in this design manual and where the project dictates.

9.1.1 PREFABRICATED BEDSIDE PATIENT UNIT (PBPU)

- (a) Each OEM produced-PBPU (i.e. Types I, II, III, IV, etc.) contains a specific NTRL (e.g., UL) Listing, for Severe Medical Applications. **Under no circumstance shall any second party equipment be attached or installed on or in the PBPU without written authorization from the PBPU OEM** and that document provided to the RE and a copy to SMCS 005OP2H3 **BEFORE** work is to commence.
- (b) During installation or VA Proof of Performance testing and certification: if a PBPU is found to have equipment installed or attached that violates its NTRL ratings, testing shall immediately cease and the entire system declared unacceptable until approved corrections are made.
- (c) It shall be the responsibility and expense of the contractor to restore the respective NTRL rating(s) per the written instructions of the PBPU OEM and the listing NTRL (e.g., UL).
- (d) *Once the corrections are made, each affected unit shall be re-inspected by SMCS 005OP2H3 at the Contractor's Expense.* Contact SMCS 005OP2H3 for specific technical assistance in scheduling the test(s).

9.1.2 SPECIALIZED TECHNICAL ASSISTANCE

Contact AHJ SMCS 005OP2H3 for design, engineering, technical, installation and certification assistance in developing a specialized TPD or Technical Specification when a Patient Wall System is required for the facility.

9.2 BEHAVIORAL HEALTH (AKA PSYCHIATRIC OR MENTAL HEALTH) AREA

9.2.1 ROOMS

(a) Patient

- Psychiatric (aka Behavioral or Mental) Health Rooms shall not contain work area outlets. When need is determined, and approved on a project-by-project basis, provide with smooth beveled, metal-edged cover plates where it and all equipment in the room/area and each is secured by tamper-proof screws to solid building structure.
- Provide Psychiatric (Mental Health) Patient Area with a color video camera monitoring system (no audio component) with clear tamper-

CHAPTER 9: SPECIAL MEDICAL AND ALARM SYSTEMS

proof camera enclosures secured with tamper-proof screws to solid facility components, in conduit and standalone design routed to the local NS for control and management

(Note - this system must be installed according to Patient Privacy and HIPAA Rules AND NOT connected to additional location[s] unless specifically pre-approved by SMCS 005OP2H3).

- Do not install equipment requiring exposed cords, wires or strings of any type or style.

(b) Holding (aka Seclusion)

- Psychiatric Holding (aka Seclusion) Rooms have 100% unobstructed view of the entire room's interior before entering.

(Note: The room entrance door is provided with a one-way reinforced glass viewing window; or, a separate wall window with one-way reinforced or electronic privacy tint glass mounted in the wall next to the door.)

- Provide the door with an electronic PACS in conduit controlled at the local NS with programming provided by the SMS in the PCR and EMCR's SCC (and OSP's EMCC if not a part of the EMCR).

(NOTE: Holding Rooms allow an unobstructed view of the entire rooms' interior before entering. Room entrance doors are provided with a one-way reinforced glass viewing window; or, a wall window with one-way reinforced glass or electronic privacy tint glass mounted in the wall next to the door. Coordinate credential reader installation with viewing window.)

- Provide a color video camera w/ audio microphone in a ceiling mounted subdued enclosure with a dark tinted tamper-proof glass cover. The camera's video and audio shall be in conduit routed in a standalone system to the associated NS for local video monitor/w audio, door management and cables looped to the local Security Room Staging Area for local color video monitor/w audio monitoring and then terminated in the SMS in the PCR and EMCR's SCC (or OSP's EMCC if not a part of the EMCR).
- Provide a flush vandal resistant subdued Duress Alarm button, on each wall, with conduit to the local NS, local Security Staging Area and managed by the SMS in the PCR's SCC (and OSP's EMCC if not a part of the EMCR).

9.2.2 AREA DOOR CONTROL AND SIGNAL SYSTEM

(a) Entrance / Exit:

- Provide the Psychiatric (AKA Behavioral or Mental Health) Area with a PACS Based Electronic Entrance / Exit Door Locking Control System, in conduit, with Audio Intercom (IC) in an interface unit at each area's entrance / exit door. Terminate the system initially in the local NS Door Control Console then in the SMS at the PCR and EMCR's SCC (and OSP's EMCC if not a part of the EMCR).

CHAPTER 9: SPECIAL MEDICAL AND ALARM SYSTEMS

- The IC may have a separate color video camera or one that is combined into a single control unit at each door.
 - Each door control unit shall contain: two (2) pushbuttons, electric locking mechanism, speaker/microphone (in a single unit), color video camera (if approved) and auxiliaries.
 - Each NS Door Control Console shall be provided with: chime (with adjustable volume), pushbutton, speaker/microphone (in a single unit), pilot light with red LED, video monitor and auxiliaries.
 - When the door push button is depressed, an associated chime/tone, pilot light, speaker/microphone and video monitor picture will be energized in the associated NS Door Control Console that will allow the nurse to see who's at the entrance / exit door and converse with them through the speaker / microphone. All will remain in the energized position until an associated NS Control Console push button is depressed turning them off and opening the door.
 - The door release operation shall be coordinated with the SMS PACS electric locks and system.
 - The system operation shall be fully compatible with and controlled by the SMS in the PCR and EMCR's SCC (and OSP's EMCC if not a part of the EMCR).
 - Provide stainless steel cover plate(s), with tamperproof screws for each unit.
- (b)** Signage - provide an approved durable sign under each chime and pilot light that reads "Entrance (or Exit) Door" (or approved alternate) information that is a minimum 15mm [0.5 inch] high and 30mm [1.0 inch] long and approved by AHJ SMCS.

9.2.3 SPECIALIZED TECHNICAL ASSISTANCE

Contact AHJ SMCS 005OP2H3 for design, engineering, technical, installation and certification assistance in developing a specialized TPD or Technical Specification when a Mental Health Communications and Control System is required for the facility.

9.3 NARCOTICS STORAGE ALERTING AND SIGNAL SYSTEM (NSAS)

- (a)** Provide a commercial of the shelf (COTS) NSAS that is DEA compliant and completely compatible and shall operate with the project provided NSAS vault, cabinet and/or container. The system shall, at a minimum, contain:
- Door switches and locks (that are compatible and incorporated in the respective container (vault) door approved by the DEA, door OEM and AHJ SMCS, pilot light(s), color video camera and auxiliaries.
 - The door release operation shall be coordinated with the SMS PACS electric locks.
 - Provide pilot light(s) at each vault / storage locker door and in the PCR and EMCR's SCC (and OSP's EMCC if not a part of the EMCR) that is energized only when the associated door is open.

CHAPTER 9: SPECIAL MEDICAL AND ALARM SYSTEMS

- The system shall be in conduit home run to the SCC in the PCR and EMCR (and OSP's EMCC if not a part of the EMCR) that has SCC indicating light(s), with aural tone and corresponding visual light, for each monitored door and will remain so while the door is open.
- The system operation shall be fully compatible with and controlled by the SMS in the PCR and EMCR's SCC (and OSP's EMCC if not a part of the EMCR).
- Coordinate SSTV cameras and view(s) per DEA and VA Police requirements and approved by AHJ SMCS.
- Provide stainless steel cover plate(s), with tamperproof screws for each unit.

(b) Signage

Provide an approved durable sign under each aural generating device and pilot light that reads "Vault / Narcotics Door" (or DEA approved alternate) information that is a minimum 15mm [0.5 inch] high and 30mm [1.0 inch] long and approved by AHJ SMCS.

9.3.1 SPECIALIZED TECHNICAL ASSISTANCE

Contact AHJ SMCS 005OP2H3 for design, engineering, technical, installation and certification assistance in developing a specialized TPD or Technical Specification when a **NSAS** is required for the facility.

9.4 SPECIALIZED MEDICAL TIME KEEPING DEVICES

9.4.1 MEDICAL ELAPSED TIME INDICATOR (METI)

- (a) Provide a Commercially available Off-The-Shelf (COTS) METI with 0-60 minute range clock with a minimum of ± 3 % instrument accuracy, which is completely compatible and shall operate within the project provided METI locations approved during project design. The METI shall, at a minimum, contain:
- 304.8 mm [12 inch] dial, flush or semi-flush mounted.
 - Sweep second and minute hands.
 - Black on white, large digits at five (5) minute intervals and individual second markings to insure accurate readability.
 - Rugged completely enclosed synchronous motor for quiet and trouble free operation.
 - Shock resistant and dust proof metal enclosure.

CHAPTER 9: SPECIAL MEDICAL AND ALARM SYSTEMS

- (b) Provide automatic and manual operation (selectable at user's option), with controls on the front of the enclosure for connecting remote equipment that will actuate its automatic operation. A reset switch shall be mounted on the front panel that will reset the indicator(s) to zero within five (5) seconds after its activation.
- (c) Power supply shall operate on 120 VAC, 60 Hz.
- (d) Acceptable alternate is a Digital display MTI clock with equivalent operational readability. MTI minimum display shall be 65mm [3.5 inch] high.
- (e) Contact AHJ SMCS 005OP2H3 for design, engineering, technical, installation and certification assistance in developing a specialized TPD or Technical Specification when a METI is required for the facility.

9.4.2 MEDICAL SYNCHRONIZED CLOCK SYSTEM (MSCS)

Provide a COTS Master MSCS system that has analog and digital selectable faceplate instruments.

9.4.2.1 MASTER CLOCK

The system's master clock shall be the base instrument that shall connect to and automatically update each remote clock on a selectable timed function. The master clock shall be rack / cabinet mounted and be able to update each remote clock via a standalone wired system in conduit; or, wireless, when approved by AHJ, SMCS. The MSCS shall:

- (a) Contain built in off air antenna system connectable to its off-air antenna in the Antenna Fa rm.
- (b) Have its Master Clock located in the Antenna HE Room, or remote with RF interface equipment installed in the Antenna HE Room as approved by AHJ SMCS.
- (c) Utilize Universal Coordinated Time (UCT - aka Greenwich Mean Time (GMT)) for automatic time updates.
- (d) Utilize the Global Positioning System (GPS) as the media to access the UTC Atomic Clock signals
- (e) Recognize:
 - Leap year changes.
 - Daylight saving time changes.
- (f) Operate in the following formats:
 - Analog, and / or
 - Digital.
- (g) Provide automatic and manual operation (selectable at user's option), with controls on the front of the enclosure for connecting remote equipment that will actuate its automatic operation.
- (h) Power supply shall operate on 120 VAC, 60 Hz, 25 W maximum.

CHAPTER 9: SPECIAL MEDICAL AND ALARM SYSTEMS

- (i) Possess its own UPS (battery(s)) supervised by the Master Clock and connected to the SMS in the PCR and OSP's EMCC SCCs.

9.4.2.2 REMOTE CLOCKS

- (a) Housings
 - Analog, 12 inch (300 mm), round.
 - Digital 6 inch (130 mm) high, max, with a minimum of six (6) digit read-outs.
 - Connect to the 'Master Clock' via:
 - Its own stand-alone, wired, conduit protected network, or Wireless capability approved by AHJ SMCS.
- (b) Contact AHJ SMCS 005OP2H3 for design, engineering, technical, installation and certification assistance in developing a specialized TPD OR Technical Specification when a Remote Clock is required for the facility.

APPENDIX A: DRAWINGS

APPENDIX A: DRAWINGS

The drawing shows a possible topology based on the telecommunications conduit connectivity requirements.

APPENDIX A: DRAWINGS

This page intentionally left blank.

APPENDIX A: DRAWINGS

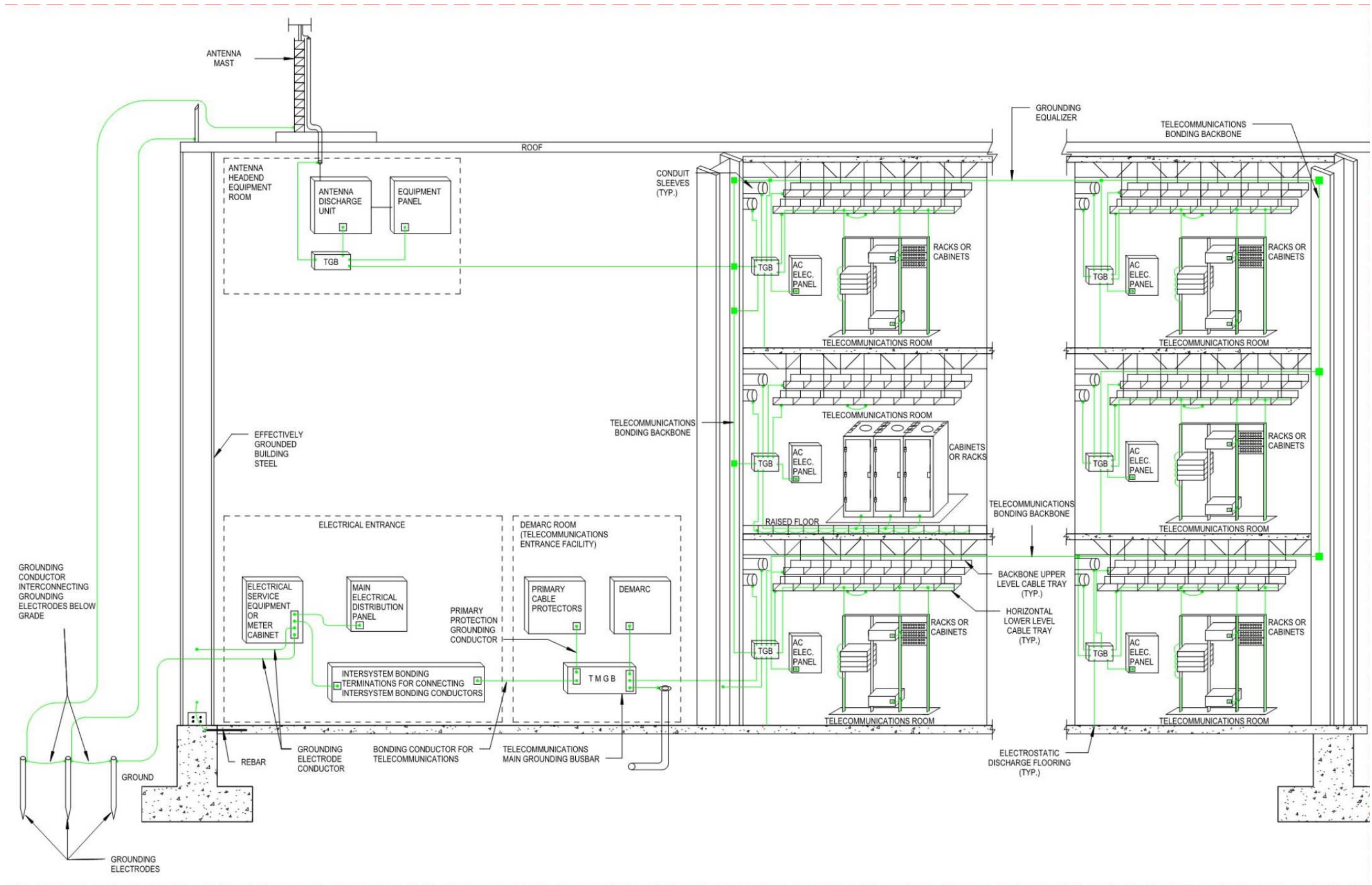

APPENDIX A: DRAWINGS

Telecommunications Grounding and Bonding

APPENDIX B: DRAWINGS

APPENDIX B: DRAWINGS

The drawing shows a possible oneline topology based on the telecommunications connectivity requirements.

APPENDIX B: DRAWINGS

APPENDIX B: DRAWINGS

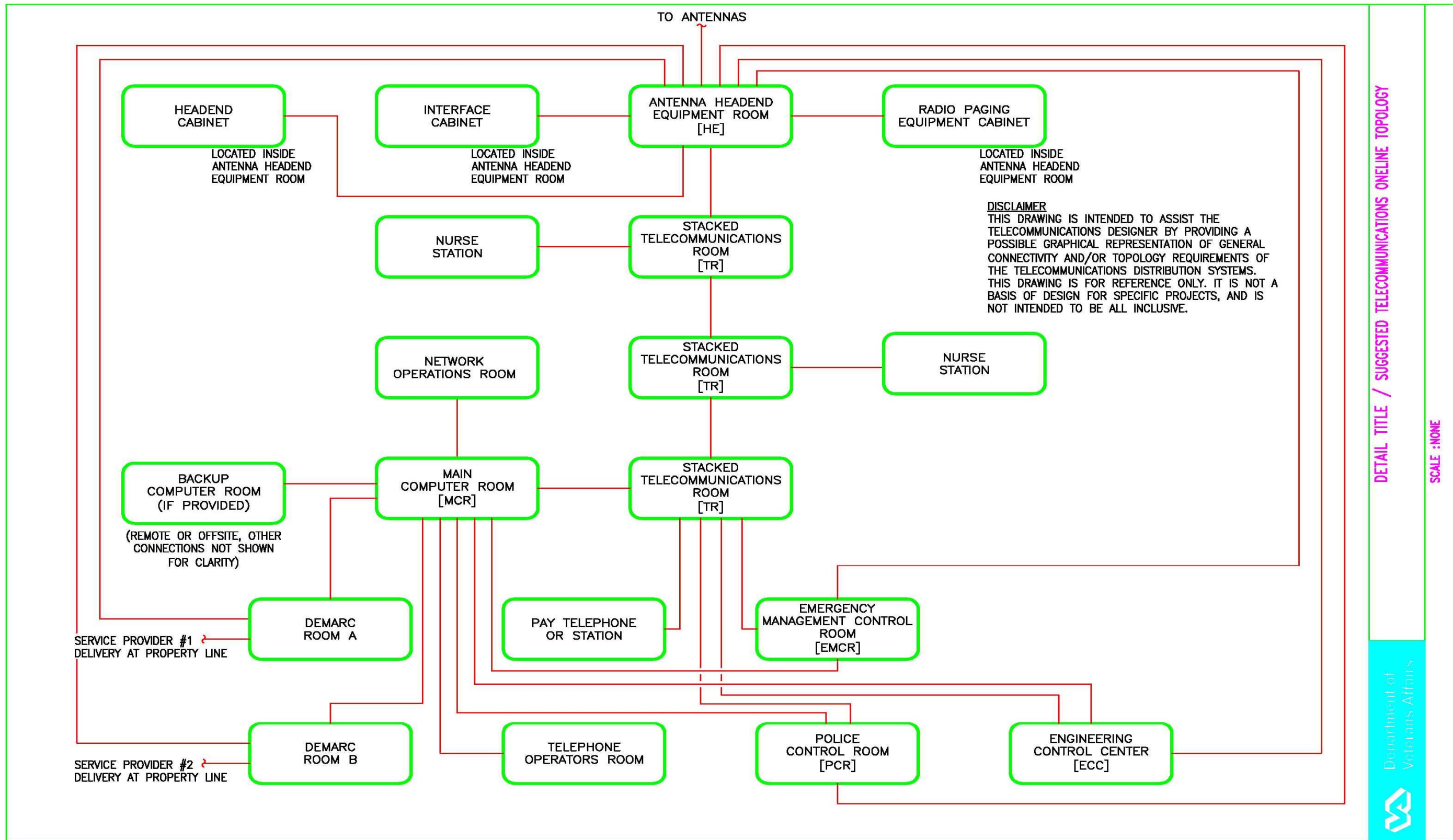

APPENDIX B: DRAWINGS

This page intentionally left blank.

INDEX

INDEX

A

AERIAL ENTRANCES.....6-5
Americans with Disabilities Act Standards for
 Accessible Design..... **3-12**
Antenna Farm.....7-6
ANTENNA HEADEND EQUIPMENT ROOM8-10
ARCHITECT/ENGINEER REVIEW CHECKLIST
 1-11
AREA DOOR CONTROL AND SIGNAL SYSTEM
 9-2
AUDIO AND VIDEO COMMUNICATION AND
 DISTRIBUTION (AVCD).....7-33
AUDITORIUM BASED
 PROFESSIONALBASEBAND AUDIO AND
 VIDEO ORGINATION AND DISTRIBUTION
 SYSTEM (ABDS).....7-31

B

BACKBONE DISTRIBUTION5-3
BACKBONE TOPOLOGIES.....5-4
BALANCED TWISTED PAIR CABLE 3-8
Balanced twisted pair cabling 3-1
BLOWN FIBER-OPTICS 5-7
Bonding within Racks and Cabinets4-3
BUILDING AUTOMATION SYSTEMS..... 3-15

C

CABLE LENGTH3-8
CABLE PATHWAYS2-0
CABLE TRAYS AND OPEN WIREWAYS2-4
CABLING TYPES5-5
CALCULATIONS1-23
Closed Circuit Television.....7-19
COMPUTER AIDED FACILITIES
 MANAGEMENT REQUIREMENTS.....1-13
CONDUIT AND BOXES..... 1-26
CONDUITS AND BOXES2-0
CONDUITS MINIMUM REQUIREMENTS2-0
CONFIGURATION8-10
COST ESTIMATING MANUAL1-12

D

DEMARC Room.....8-13
DEMARC ROOM8-6
DESIGN ALERTS1-12
Design and Construction Procedures1-8
DESIGN GUIDES1-10
Design Manuals1-8
DESIGN REQUIREMENTS1-21

DESIGN SUBMISSION REQUIREMENTS **1-11**
Direct Attach Modified Permanent Links 3-11
DISCRETE ANTENNA SYSTEM 3-7
DISTRIBUTED (IN HOUSE) ANTENNA
 SYSTEM..... 3-3
DRAWING ABBREVIATIONS AND SYMBOLS.1-
 23
DRAWINGS.....1-21, 1-24
DURESS ALARM EMERGENCY NOTIFICATION
 7-12

E

Electrical Design Manual.....1-9
ELECTRONIC ACCESS AND DOOR CONTROL7-
 21
EMERGENCY HIGH FREQUENCY TWO WAY
 RADIO7-14
EMERGENCY NOTIFICATION /
 COMMUNICATION (.....7-12
EMERGENCY SATELLITE RADIOTELEPHONE
 7-17
**EMERGENCY TELEPHONE LINE BY-PASS
 MICROWAVE..... 7-14**
EMERGENCY VOICE SWITCHING CONTROL
 (EVCS)7-16
EMERGENCY WITHIN BUILDING
 DISTRIBUTED RF ANTENNA (DAS).....7-17
ENERGY CONSERVATION1-14
ENTRANCE FACILITIES6-3
EQUIPMENT BRACING.....1-24
Equipment Reference Manual (PG-18-5).....1-8
ETHYLENE OXIDE STERILIZATION AREA 2-10
EXTERIOR OUTLETS3-10

F

Facility Lightning Protection System4-4
Fire Protection.....1-19, 1-23, 8-11, 8-17, 8-18
FIRE PROTECTION8-11

G

Grounding4-1, 4-4, 7-5, 8-15, 8-19
GROUNDING.....8-11

I

INDOOR CONDUITS AND PATHWAYS.....2-6
INSULATION DISPLACEMENT BLOCKS5-8
INTERCOMMUNICATION (ICS)7-15
INTERCONNECTING CONDUIT
 REQUIREMENTS2-1
INTERSYSTEM BONDING4-1

INDEX

L

LABORATORIES AND RESEARCH FACILITIES3-11
LIGHTING8-9
LOADS FED FROM UNINTERRUPTIBLE
POWER SUPPLY (UPS)5-9
LOCAL CODES AND CONDITIONS1-20
LOCAL UTILITY1-21
Location...3, 1-20, 2-3, 7-7, 7-18, 7-26, 7-28, 7-30,
7-35, 8-13, 8-14, 8-18, 8-20

M

MAIN COMPUTER OPERATORS ROOM
(MCOR).....8-7
Maintenance Holes (MH) (formerly manholes). 6-
6
MASTER ANTENNA TELEVISION (MATV) **7-23**
Master Specifications 1-7
MEDICAL ELAPSED TIME INDICATOR9-4
MOTION INTRUSION DETECTOR (MID) ...7-20

N

NARCOTICS STORAGE ALERTING AND
SIGNAL SYSTEM (NSAS)9-3
National CAD Standard..... 1-8
NATIONAL CEMETERY ADMINISTRATION
NETWORK CABLING SPECIFICATIONS 1-10

O

Office of Information & Technology Design Guide
..... 1-10
OFFICES AND ADMINISTRATIVE AREAS ...3-11
OI&T WIRELESS FIDELITY (WI-FI) SYSTEM. 7-
36
OPTICAL FIBER CONSIDERATIONS5-6
OUTSIDE PLANT (OSP) CABLING.....5-4

P

PATCH PANELS5-9
PATIENT WALL SYSTEMS 9-1
PHYSICAL SECURITY DESIGN MANUAL
(PSDM).....**1-9**
POKE-THRU, TELE-POWER POLE 2-10
POLICE, ENGINEERING, AND EMERGENCY
MANAGEMENT CONTROL ROOMS, AND
OTHER DESIGNATED ROOMS..... 8-8
Pre-Design Site Survey 1-7
PREFABRICATED BEDSIDE PATIENT UNIT
(PBPU) 9-1
PROPRIETARY ITEMS 1-23
PUBLIC ADDRESS (PAS)..... 7-10

Q

QUALITY ALERTS 1-12

R

RADIO ENTERTAINMENT DISTRIBUTION
(RED)..... 7-24
RADIO FREQUENCY IDENTIFICATION (RFID)
..... 7-36
RADIO PAGING (RPS) 7-11
RATED CONSTRUCTION 2-10
ROOM SIZE..... 8-11
ROUTE DIVERSITY..... 5-4

S

Security 7-21, 7-37, 8-9, 8-13, 8-19
SECURITY MANAGEMENT AND CONTROL,
AND CENTRALIZED POLICE SECURITY
MANAGEMENT (SMS)7-21
SECURITYSURVEILLANCE TELEVISION
(SSTV).....7-19
SEISMIC BRACING1-24
Service Provider Coordination1-6
SPARE CONDUITS 2-8
SPECIAL MEDICAL SYSTEMS (SMTS)7-37
SUPPLEMENTAL BONDING GRID (SBG)
(A.K.A. UNDERFLOOR GROUNDING
GRIDS) 4-2
SURGERY ROOMS 3-10
SUSTAINABLE DESIGN AND ENERGY
REDUCTION MANUAL..... 1-12

T

TELECOMMUNICATIONS BONDING
BACKBONE 4-2
TELECOMMUNICATIONS INFRASTRUCTURE
PLANT (TIP) 5-3
TELECOMMUNICATIONS OUTLETS (TCO) . 2-5
TELECOMMUNICATIONS ROOMS..... 3-12, 5-9
TELEPHONE EQUIPMENT (TER) AND
TELEPHONE OPERATORS ROOMS (TOR) 8-17
TELEVISION BROADCAST SATELLITE RADIO
FREQUENCY FACILITY (TBRF) 7-26
TELEVISION PRODUCTION (AUDIO AND
VIDEO) STUDIO FACILITY (TVSF) 7-29
TIP REQUIREMENTS 5-3

U

UNDERGROUND DUCTS AND CONDUITS .. 2-6
UNDERGROUND ENTRANCES..... 6-5

INDEX

V

VA DIRECTIVE 0730 – VA SECURITY AND LAW ENFORCEMENT HANDBOOK.....	1-10
VA HOSPITAL BUILDING SYSTEM (VAHBS)	1-13
VERTICAL RISERS	2-4
Very Small Aperture Satellite Telecommunication (V-SAT) - for Office of Emergency Management and Resilience (OSP)	7-18
Veterans Benefits Administration.....	1-14
VHA Application Guide	1-8
VIDEO SURVEILLANCE	3-11
VIDEO TELECONFERENCING SYSTEM (VTS)7- 25	
V-SAT (for Office of Education) (OED)	7-25
V-SAT (for OI&T).....	7-35

W

Wireless and Frequency Coordination	3-2
---	-----

INDEX

This page intentionally left blank.